

Description

The [ZMOD4450](#) Gas Sensor Module is designed for detecting gases associated with food ripening or rotting, and is targeted for use in refrigeration air quality (RAQ) applications (e.g., food storage and shipping, including humid and dusty applications with the possibility of water spray, condensation, or immersion). It is a 12-LGA assembly (3.0 × 3.0 × 0.7 mm) that consists of a gas sense element and a CMOS signal conditioning IC. The module's sense element consists of heater element on a Si-based MEMS structure and a metal oxide (MOx) chemiresistor. The signal conditioner controls the sensor temperatures and measures the MOx conductivity, which is a function of the gas concentration. The measurement results can be read via an I²C interface with the user's microprocessor, which processes the data.

The provided firmware can be used to determine the level of gases present and to indicate the likelihood of food spoilage. With its low operating current consumption, the ZMOD4450 is an excellent choice for low-voltage and low-power battery applications. Built-in nonvolatile memory (NVM) stores the module configuration and calibration data.

Typical Applications

- Refrigerator systems control
- Measurement of meat, fruit and vegetable quality
- Monitors for shipping and storage conditions
- Odor remediation systems

Available Support

- ZMOD4450 Evaluation Kit
- Manuals, application notes, and white papers
- Instructional videos
- Programming libraries, example codes, and algorithm support to optimize performance

Features

- Measurement of gases associated with food ripening and storage: volatile organic compounds (including ethylene), amines, volatile sulfur compounds
- Configurable methods of operation based on application and use case
- Heater driver and regulation loop for constant resistance, minimizing effect of environmental temperature on signal
- I²C interface: up to 400kHz
- Built-in nonvolatile memory (NVM) for module-specific data
- Low average power consumption in the mW range
- Firmware upgradable platform for application optimizations
- No external trimming components required
- External reset pin (active-LOW)
- Customization for mobile, industrial, and consumer applications
- Siloxane resistant
- RoHS compliant
- Supply voltage: 1.7V to 3.6V
- Package: 12-LGA
- Target operation temperature: 0°C to 25°C
- Water and dustproof versions available (IP67 certified)
- Available assembly sizes:
 - 3.0 × 3.0 × 0.7 mm (standard version)
 - 3.0 × 3.0 × 0.9 mm (IP67 version)

ZMOD4450 Application Circuit

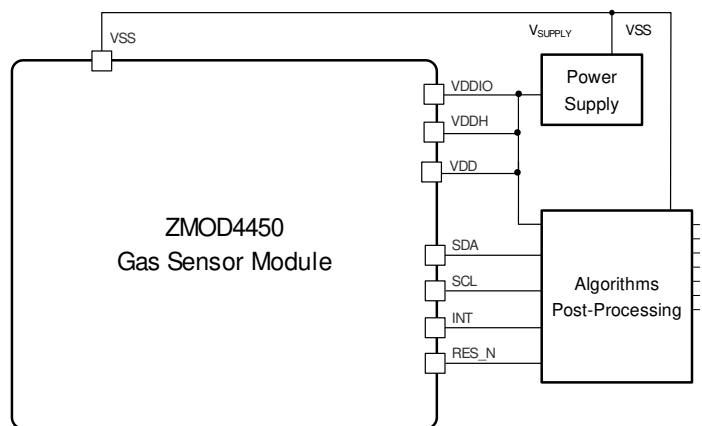

Contents

1. Pin Information	4
1.1 Pin Assignments.....	4
1.2 Pin Descriptions.....	4
2. Absolute Maximum Ratings.....	5
3. Operating Conditions.....	5
4. Electrical Characteristics	6
5. Block Diagram	7
6. Sensor Module Characteristics.....	8
6.1 Gas Sensor Module.....	8
7. Gas Sensor Module Characteristics	9
7.1 Characteristics for Typical Gas Stimulation.....	9
7.2 Environmental Temperature and Humidity	10
7.3 Accuracy and Conditioning.....	10
7.4 Sensor Module Algorithm and Firmware	11
8. Assembly Restrictions, Operation, Integration Notes, and Storage.....	11
9. Test and Calibration	12
10. I2C Interface and Data Transmission Protocol.....	13
11. Glossary	15
12. Package Outline Drawings	16
13. Marking Diagram	16
14. Ordering Information.....	16
15. Revision History.....	17

List of Figures

Figure 1. Pin Assignments for 12-LGA Module – Top View.....	4
Figure 2. Gas Response to Typical Gases and Levels of Expected Refrigeration Gases.....	9
Figure 3. Humidity Influence at 4°C for Ethylene Stimulation.....	10
Figure 4. Typical Solder Profile.....	12
Figure 5. I2C Data Transmission Protocol.....	13
Figure 6. Bus Timing.....	14

List of Tables

Table 1.	Pin Descriptions.....	4
Table 2.	Absolute Maximum Ratings.....	5
Table 3.	Operating Conditions.....	5
Table 4.	Electrical Characteristics	6
Table 5.	Gas Sensor Module Specifications.....	8
Table 6.	Default Parameters for Control Signal based on Air Quality Changes	10
Table 7.	Typical ZMOD4450 Sensor Module Accuracy Achievable with Calibration.....	11
Table 8.	Final Test Parameters	12
Table 9.	Bus Timing Characteristics.....	14
Table 10.	Package Options	16

1. Pin Information

1.1 Pin Assignments

Figure 1. Pin Assignments for 12-LGA Module – Top View

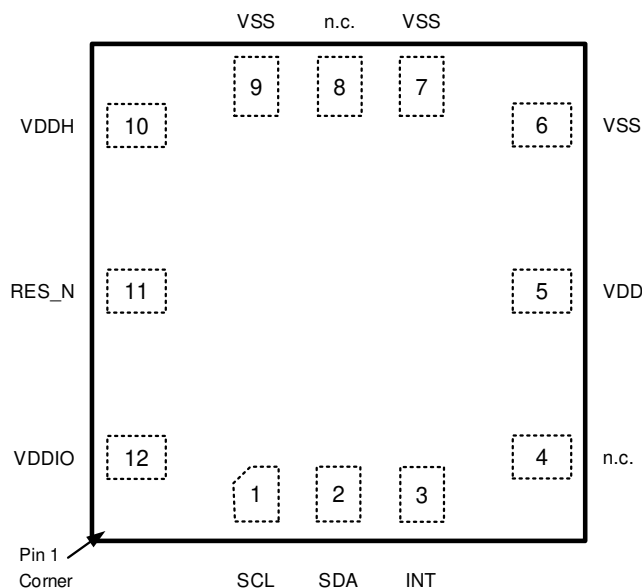

1.2 Pin Descriptions

Table 1. Pin Descriptions

Pin Number	Name	Type	Description
1	SCL	Input	Serial clock for the I2C interface.
2	SDA	Input/Output	Serial data for the I2C interface. Default 7-bit slave address: 32 _{HEX} .
3	INT	Output	Interrupt signal (push-pull). <ul style="list-style-type: none"> • HIGH when a measurement is running • LOW when a measurement has finished Note, use edge detection on falling edge!
4	n.c.	–	Do not connect.
5	VDD	Supply	Voltage supply for the ZMOD4450.
6	VSS	Ground	Ground reference for the ZMOD4450.
7	VSS	Ground	Ground reference for the ZMOD4450.
8	n.c.	–	Do not connect.
9	VSS	Ground	Ground reference for the ZMOD4450.
10	VDDH	Supply	Voltage supply for the integrated heater in the ZMOD4450.
11	RES_N	Input	ZMOD4450 reset; active low.
12	VDDIO	Supply	Voltage supply for I/O-interface in ZMOD4450.

2. Absolute Maximum Ratings

Note: The absolute maximum ratings are stress ratings only. The ZMOD4450 may not function above and below the recommended operating conditions in Table 3. Stresses exceeding the absolute maximum ratings will change the sensor module accuracy, lead to imprecision, and eventually cause irreversible damage to the device. In addition, extended exposure to stresses above the recommended operating conditions might affect device reliability. Renesas does not recommend designing to the “Absolute Maximum Ratings.”

Table 2. Absolute Maximum Ratings

Symbol	Parameter	Minimum	Maximum	Unit
$V_{DD}, V_{DDH}, V_{DDIO}$	Maximum Analog and I/O Supply Voltage	-0.4	3.63	V
V_{A_IO}, V_{D_IO}	Maximum Voltage at all Analog and Digital I/O Pins	-0.5	$V_{DDIO} + 0.5$	V
	Maximum Difference in Voltage between VDD and VDDH Pins	–	0.4	V
I_{IN}	Input Current into any Pin Except Supply Pins (Latch-Up Immunity)	-100	100	mA
V_{HBM1}	Electrostatic Discharge Tolerance – Human Body Model (HBM)	–	2000	V
V_{CDM}	Electrostatic Discharge Tolerance – Charged Device Model (CDM) on Packaged Module	–	750	V
$T_{AMB-MAX}$	Maximum Ambient Temperature Range of Sensor Module	-40	125	°C
T_{STOR}	Storage Temperature	-50	125	°C

3. Operating Conditions

Note: The reference for all voltages is V_{SS} .

Table 3. Operating Conditions

Symbol	Parameter	Minimum	Typical	Maximum	Unit
V_{DD}	Supply Voltage for ZMOD4450 Sensor Module	1.7	–	3.6	V
T_{AMB}	Ambient Temperature Range for Sensor Module Operation	-40	25	65	°C
$T_{OPERATION}$	Operation Temperature Sequence of Sense Element ^[a]	–	300	–	°C

[a] Controlled via API in firmware and EVK software.

4. Electrical Characteristics

Values below are valid at operating conditions unless noted otherwise.

Table 4. Electrical Characteristics

Symbol	Parameter	Conditions	Minimum	Typical	Maximum	Unit
	Average Power ZMOD4450	Continuous Operation	–	23	–	mW
I _{ACTIVE}	Supply Current, Active Mode including Heater Current.	At VDD = 1.8V		13		mA
		At VDD = 3.3V		7		mA
I _{SLEEP}	Current during measurement delays	Sleep Mode ASIC	–	450	–	nA
PSRR	Power Supply Rejection Ratio	VDD ≥ 2.0V	–	30	–	dB
	Timing Accuracy (Valid for Measurements Only) (Sleep Timer is ±20%)	At room temperature; for timings derived from the internal clock	-2	–	2	%
		Over-temperature range; for timings derived from the internal clock	-0.1	–	0.1	%/K
t _{ADC}	ADC Resolution		10	–	16	Bit
t _{STA1}	Start-up Time: VDD Ramp up to Interface Communication		–	–	1	ms
f _{C,I2C}	I2C Clock Frequency		–	–	400	kHz
t _{VPP}	NVM Programming Time		–	6	16	ms
t _{RET_FTP}	Data Retention	85°C junction temperature	10	–	–	years
	NVM Programming Cycles		1000	–	–	cycles
	Default Communication Address	7-bit slave address	–	32HEX	–	–
	Blocking Capacitor for Power Supply	Ceramic type; recommended to be placed close to gas sensor module	100	–	–	nF

5. Block Diagram

Note: See section 10 for definitions of abbreviations.

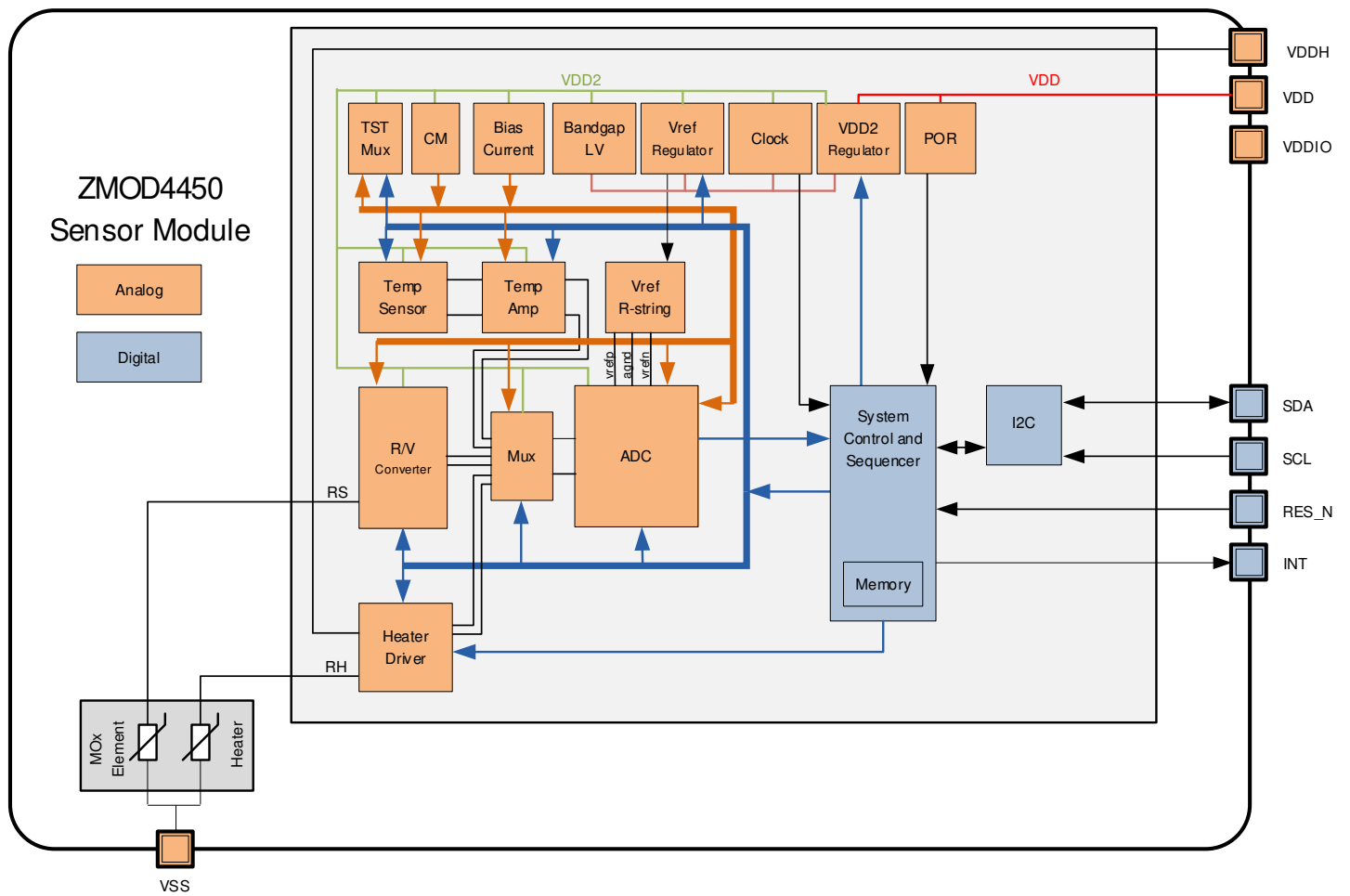

6. Sensor Module Characteristics

6.1 Gas Sensor Module

The ZMOD4450 Gas Sensor Module is designed to detect typical gases inside refrigeration applications associated with food ripening or rotting. Specifications for sensor module operation are shown in Table 5. The response time for a gas stimulation is always within a few seconds, depending on the gas and its concentration. An active or direct airflow onto the sensor module is not necessary since diffusion of ambient gas does not limit the sensor module response time.

Important: The ZMOD4450 can also detect some safety-relevant toxic gases; however, the sensor module is not designed to detect these interferants reliably, and it therefore is not approved for use in any safety-critical or life-protecting applications. It must not be used in such applications, and Renesas disclaims all liability for any such use.

Table 5. Gas Sensor Module Specifications

Symbol	Parameter	Conditions	Minimum	Typical	Maximum	Unit ^[a]
	Measurement Range	Ethylene (C ₂ H ₄) in air	0		10	ppm
	Measurement Range	Trimethylamine (C ₃ H ₉ N) in air	0		600	ppb
	Measurement Range	Dimethyl sulfide (C ₂ H ₆ S) in air	0		180	ppb
RAQ	Refrigeration Air Quality Range	Change rate based on resistance	0		3	
	Temperature Range		0		25	°C
	Repeatability	Variation in sensor module signal		±10		%
T-90	Sensor Module Response Time	Time to change to 90% of end value		10		sec

[a] The abbreviation ppm stands for “parts per million,” and ppb is an abbreviation for “parts per billion.” For example, 1 ppm equals 1000 ppb.

7. Gas Sensor Module Characteristics

Additional information about sensitivity and sensor module influences are explained in the following sections. All graphs and information show the typical responses that are to be expected from the ZMOD4450 Gas Sensor Module upon exposure to a variety of test conditions. For more information, including application notes, white papers, blog, and manuals, visit the [ZMOD4450](#) webpage.

7.1 Characteristics for Typical Gas Stimulation

The ZMOD4450 also allows controlling an external device, such as an active air filter or ozone generator, based on the air quality changes. Although the sensor module is not selective to an individual gas, it detects a variety of volatile organic and sulfur compounds. Figure 2 shows the sensor module response to the most relevant organic and sulfur-based gases associated with food quality. The ZMOD4450 is also sensitive to additional gases (e.g., Octanal, Hexaldehyde, and Ammonia); however, sensitivity data is not illustrated for these gases in the figure.

Figure 2. Gas Response to Typical Gases and Levels of Expected Refrigeration Gases

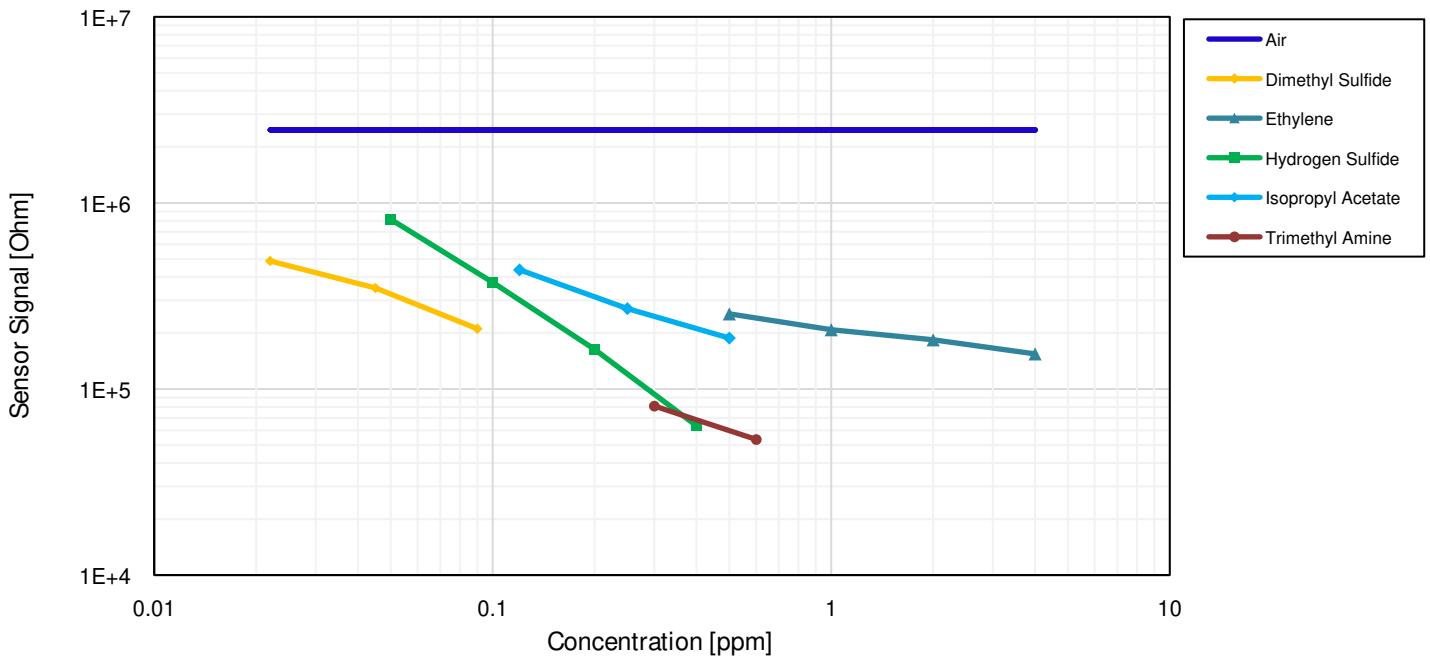

The sensor module outputs are raw resistance measurements and an algorithmic calculation of the refrigeration air quality change (RAQ), which indicates a total air quality change over time inside the refrigeration application. Therefore, the ZMOD4450 algorithms give a relative output signal. RAQ is a ratio of concentrations and defined as the following:

- < 1: Improvement of air quality, overall gas concentration is falling
- = 1: No change in air quality
- > 1: Deterioration of air quality, overall gas concentration is rising

In addition, a control state is given, which shows the status of a user-defined threshold.

Renesas provides firmware and algorithms, which allow the ZMOD4450 to learn the refrigeration environment. The gas sensor module will immediately respond to changes in the refrigeration air by detecting changes in the relative gas concentrations. When the user-defined threshold is exceeded, an I/O control signal (trigger) based on the algorithm output can be used to control an external device.

Table 6. Default Parameters for Control Signal based on Air Quality Changes

Parameter	Conditions	Typical Value	Unit
Learning Time Environment	Typical value valid for sample rate of 2 seconds	60	min
Sensor Module Response Time	Sample rate dependent, typically 1 to 3 samples	10	s
Threshold Trigger	Change of concentration; recommended difference: 30%	1.3	–
Stop Delay	Stop delay for external device; defines minimum activation time	2	min

When using the ZMOD4450 Evaluation Kit, the AD5 pin (GPIO) on connector K3 on the HiCom Communication Board is the trigger control signal output that is set to HIGH/LOW. For more details, refer to the *ZMOD4450 Evaluation Kit User Manual*.

7.2 Environmental Temperature and Humidity

The sensor module is tested, qualified, and functional in the operation range of 0°C to +25°C. Figure 3 shows the module's response during operation to variations in relative humidity with and without ethylene stimulation.

Figure 3. Humidity Influence at 4°C for Ethylene Stimulation

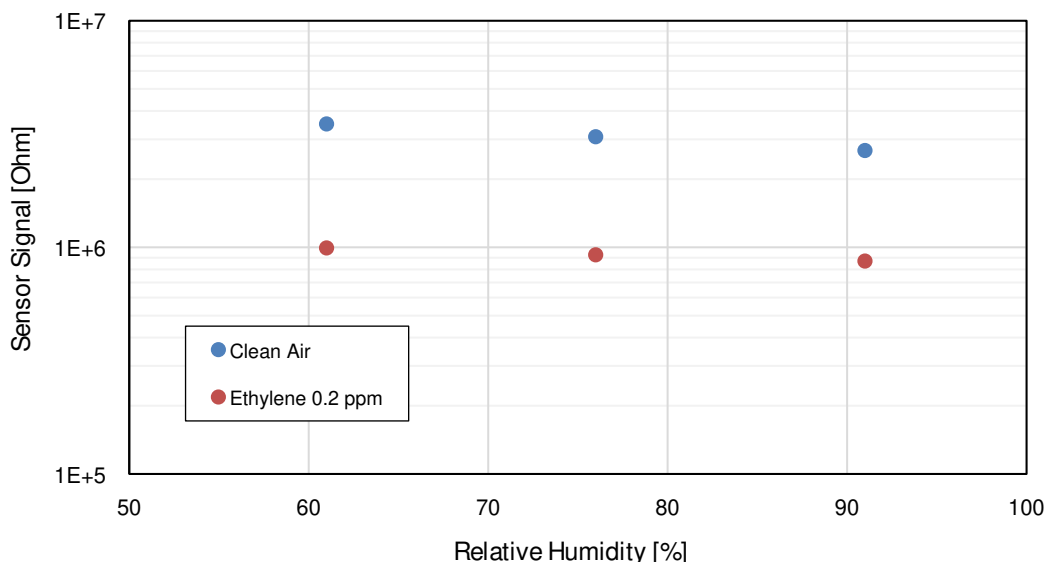

7.3 Accuracy and Conditioning

All Renesas gas sensor modules come with electrical and chemical factory calibration with data stored in the module's nonvolatile memory (NVM). Using the software provided by Renesas and the calibration coefficients in the NVM will lead to stable measurements. The ZMOD4450 will respond to typical refrigeration gases immediate upon start-up; however, a conditioning period of 48 hours in a refrigeration environment is recommended to improve stability and get maximum performance, as the module algorithm is able to learn about the refrigeration environment over time.

Users who require an absolute measurement with the maximum achievable accuracy are advised to re-calibrate the sensor module with a known organic compound. This enables an absolute accuracy of ±15% (see Table 7). For some environments, an interference response to siloxanes is of concern; however, the ZMOD4450 gas sensor module is proven to be resistant against siloxanes. A maximum potential life-time exposure has been simulated in all ZMOD4450 operation modes by applying the chemicals D4 (octamethylcyclotetrasiloxane) and D5 (decamethylcyclopentasiloxane) in high concentration for several hundred hours.

Table 7. Typical ZMOD4450 Sensor Module Accuracy Achievable with Calibration

Parameter	Conditions	Minimum	Typical	Maximum	Unit
Accuracy	With additional calibration		±15		%
Consistency	Part-to-Part Variation		±25		%
Durability to Siloxanes	Change in sensitivity		±5		%

7.4 Sensor Module Algorithm and Firmware

To operate the ZMOD4450, the software and libraries provided by Renesas should be used. The algorithm for the user's microprocessor always uses the raw output signals from the ZMOD4450, which are resistances, to determine the change of RAQ gases. Depending on the microprocessor and compiler used, the firmware and its algorithms require 10 to 20 kB flash size. All algorithms feature an automated baseline correction function, ensuring that the module can learn from its environment and distinguish elevated levels of gases under all conditions. The proprietary metal oxide (MOx) used in the sensor ensures that the sensor module can respond effectively to changing RAQ gases during long-term operation. Therefore, the user focus should always be on the relevant output parameter: The Air Quality Change Rate.

For implementing the sensor module in a customer-specific application, detailed information on the programming is available. More information and guidance on the firmware integration, architecture, and supported platforms are available in the *ZMOD4450 Programming Manual – Read Me*. Code Examples in C and additional firmware descriptions for API, HAL, libraries, etc., are included at no cost in the downloadable firmware package from the ZMOD4450 product page.

8. Assembly Restrictions, Operation, Integration Notes, and Storage

When implementing the ZMOD4450 in electrical circuit boards, a gas sensor module may react to chemicals during the assembly process and to outgassing components, such as resins from the printed circuit board (PCB) assembly. A standard soldering profile can be used to assemble the ZMOD4450 on the user's PCB and should fulfill the IPC/JEDEC J-STD-020C Standard ("Moisture/Reflow Sensitivity Classification for Non-hermetic Solid State Surface Mount Devices"). A typical lead-free reflow solder profile is shown in Figure 4. After assembly, an outgassing of the PCB and electronic components must be considered, especially when operating the sensor module at elevated temperatures. This will ultimately influence the sensor module signal and may dominate the air quality reading. A PCB heat treatment before assembling the ZMOD4450 is recommended. After the gas sensor module assembly, no coating, cleaning, or ultrasonic bath should be applied to the PCB. Also, in case the sensor module's parts are contaminated during assembly or storage, the device can be cleaned after assembly by using the cleaning library provided with the firmware to remove any contamination of solder vapor from the MOx surface. In case the sensor module does not show full performance after a cleaning cycle, a change to the protection sticker package is recommended (see Ordering Information). Store the sensor module in an antistatic metallic bag with a low TVOC background after the sensor module is removed from its original packaging or the assembled PCB is populated. The optimal storage conditions are < 1 ppm TVOC, < 100 ppb O3, < 100 ppb NO2, 10°C to 50°C, and humidity levels within 20% to 80%RH. If the sensor module is stored outside of these conditions for extended periods of time, the sensor module readings can exhibit a temporary offset. The sensor module can be reconditioned and brought back to its calibration state by operation for 24 to 48 hours in clean air.

To receive the *Renesas Gas Sensor Guidelines* with detailed information and on assembly, material outgassing, test and validation procedures, contact Renesas via the contact information on the last page.

Figure 4. Typical Solder Profile

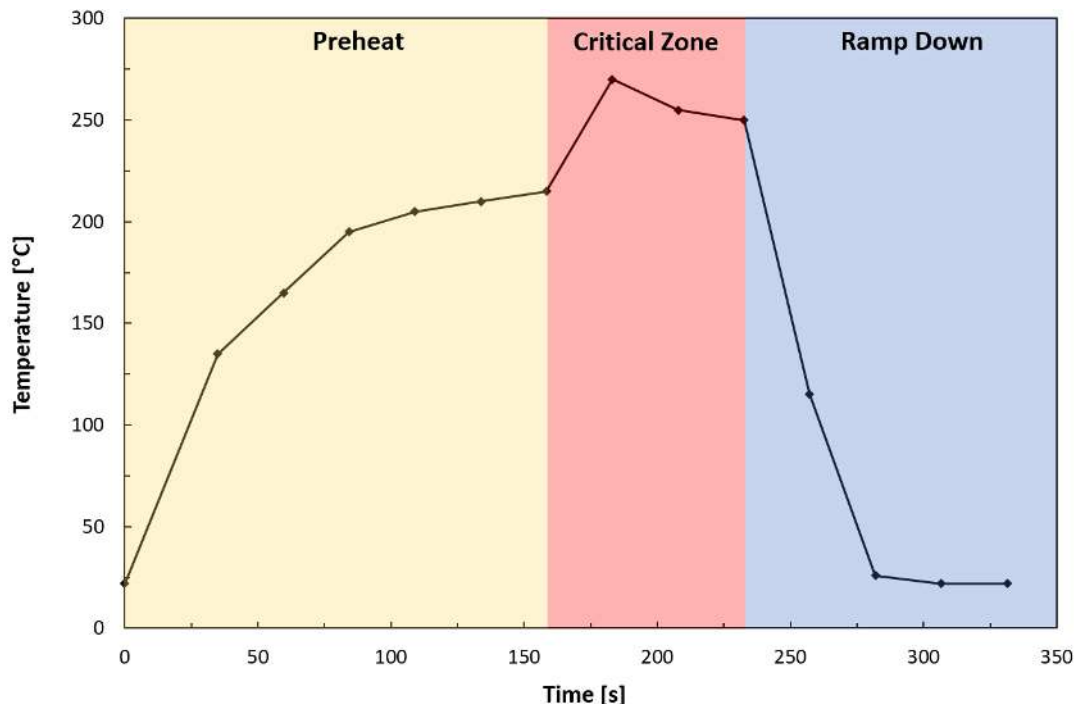

9. Test and Calibration

As a unique feature, all sampled gas sensor modules are fully tested by Renesas during the final test. The final test parameters in Table 8 are applied for each ZMOD4450. All sensor modules are pre-stabilized in the final test although the user may see a small change in the module’s raw signal during an initial warm-up phase during the first operation. The gas sensor module qualification is based on JEDEC (JESD47) and its subsequent standard (JESD22, JESD78, etc.); it has been tested for a lifetime of 10 years. Renesas has proven a MOx lifetime of over 15 years in actual continuous operation in conditions without exposure to stressful environments.

Table 8. Final Test Parameters

Test	Test Object	Parameters	Test Results Saved in NVM?
Electrical	ASIC	Voltages, current consumption, frequencies, scan pattern	No
Electrical	Module	Calibration conditions, tracking ID, resistances	Yes
Gas	Module	Sensitivity parameters (slope and intercept) at stimulation with different gas concentrations	Yes
Gas	Module	Pre-stabilization	No

10. I2C Interface and Data Transmission Protocol

The I2C slave device interface supports various bus speeds: Standard Mode ($\leq 100\text{kHz}$) and Fast Mode ($\leq 400\text{kHz}$).

By default, the 7-bit slave address for the serial I2C data interface is set to 32_{HEX}. The implemented data transmission protocol is similar to the one used for conventional EEPROM devices. The register to read/write is selected by a register address pointer. This address pointer must be set during an I2C write operation. For read access a repeated START condition but no STOP condition should be sent. After transmission of a register, the address pointer is automatically incremented. An increment from the address FF_{HEX} rolls over to 00_{HEX}.

For an example of the I2C data transmission protocol, see Figure 5. For information on I2C bus timing, see Figure 6. For I2C bus characteristics, see Table 9, which explains how to set up the interface. All other values are according to the I2C standard. Although the ZMOD4410 has an I2C interface, the user is not intended to modify any registers because a configuration change will affect the sensor module's performance, reliability, and accuracy. The API provided with the downloadable firmware package on the website manages all necessary sensor module communication.

To validate the general MCU-specific I2C read/write driver without the use of Renesas libraries, it is possible to write random values to registers 0x88 to 0x8B and read them afterwards. After this register testing, erase the testing code and reset the device by disconnecting the power supply; otherwise the device may not operate properly.

Figure 5. I2C Data Transmission Protocol

WRITE Access RAM

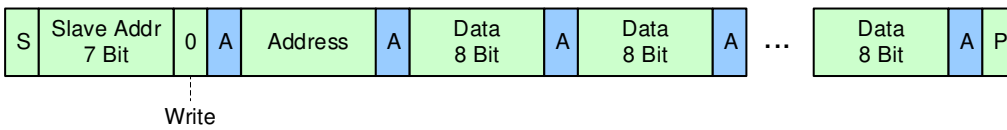

READ Access NVM and RAM

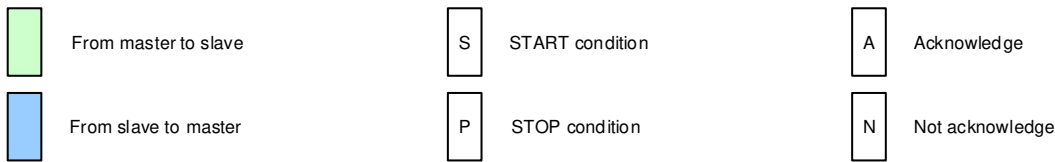
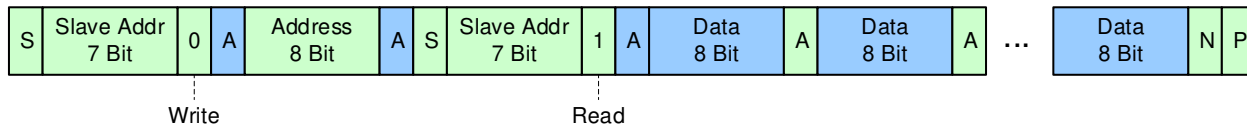

Figure 6. Bus Timing

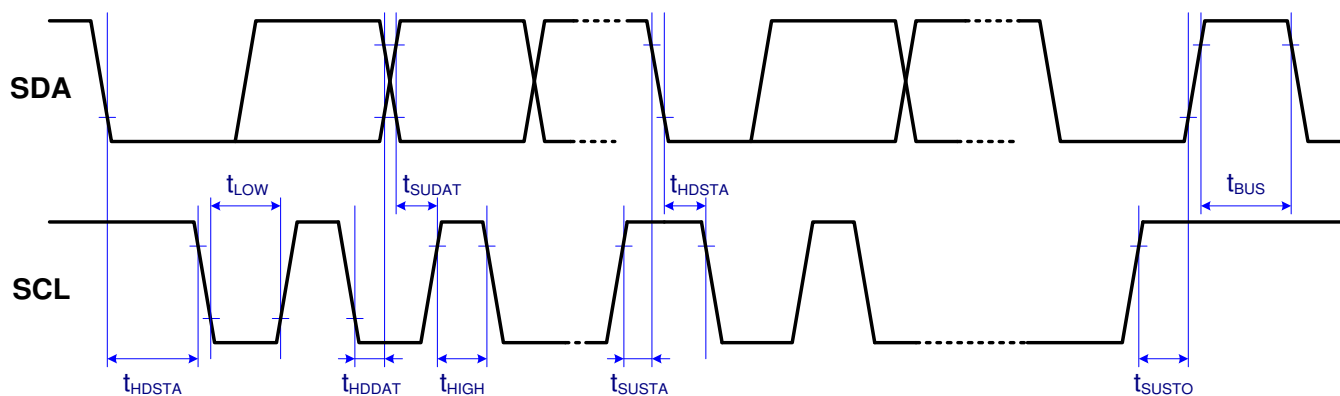

Table 9. Bus Timing Characteristics

Symbol	Parameter	Standard Mode	Fast Mode	Units
f_{SCL}	Maximum SCL clock frequency	100	400	kHz
t_{HDSTA}	Minimum START condition hold time relative to SCL edge	4		μs
t_{LOW}	Minimum SCL clock LOW width	4.7		μs
t_{HIGH}	Minimum SCL clock HIGH width	4		μs
t_{SUSTA}	Minimum START condition setup time relative to SCL edge	4.7		μs
t_{HDDAT}	Minimum data hold time on SDA relative to SCL edge	0		μs
t_{SUDAT}	Minimum data setup time on SDA relative to SCL edge	0.1	0.1	μs
t_{SUSTO}	Minimum STOP condition setup time on SCL	4		μs
t_{BUS}	Minimum bus free time between stop condition and start condition	4.7		μs

11. Glossary

Term	Description
ADC	Analog-to-Digital Converter
CDM	Charged Device Model
CM	Common Mode Generator
HBM	Human Body Model
LGA	Land Grid Array
LV	Low Voltage
MOx	Metal Oxide
MSL	Moisture Sensitivity Level
Mux	Multiplexer
n.a.	Not Applicable
NVM	Nonvolatile Memory
POR	Power-On Reset
SDA	Serial Data
SCL	Serial Clock
RAQ	Refrigeration Air Quality
SSC	Sensor Signal Conditioner
TST	Test
TVOC	Total Volatile Organic Compounds

12. Package Outline Drawings

The ZMOD4450's different packages are listed in Table 10.

Table 10. Package Options

Part Number	Version	Comment	Package Link
ZMOD4450AI1	Standard	Standard package	LGG12D1 package
ZMOD4450AI2	Sticker	This package shipped with a sticker on top of the lid to protect the sensor module during assembly. Note, the sticker has to be removed after assembly.	
ZMOD4450AI3	Waterproof	This package uses a membrane to get IP67 rating	LVG12D2 package
ZMOD4450AI4	Waterproof + Sticker	This package uses a membrane to get IP67 rating and a sticker on top of the lid to protect the sensor module during assembly. Note, the sticker has to be removed after assembly.	

13. Marking Diagram

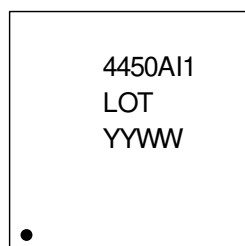

- Line 1 is the truncated part number.
- Line 2 – “LOT” denotes the assembly lot number.
- Line 2 – “YYWW” are the last two digit of the year and week that the part was assembled.

14. Ordering Information

Part Number	Description and Package	MSL Rating	Carrier Type	Temperature
ZMOD4450AI1V	ZMOD4450 Sensor Module, 3.0 × 3.0 × 0.7 mm 12-LGA	3	Tray	0°C to +25°C
ZMOD4450AI1R	ZMOD4450 Sensor Module, 3.0 × 3.0 × 0.7 mm 12-LGA	3	Reel	0°C to +25°C
ZMOD4450AI2V	ZMOD4450 Sensor Module, 3.0 × 3.0 × 0.7 mm 12-LGA, shipped with removable protection sticker	3	Tray	0°C to +25°C
ZMOD4450AI2R	ZMOD4450 Sensor Module, 3.0 × 3.0 × 0.7 mm 12-LGA, shipped with removable protection sticker	3	Reel	0°C to +25°C
ZMOD4450AI3V	ZMOD4450 Sensor Module, 3.0 × 3.0 × 0.9 mm 12-LGA, IP67 rating	3	Tray	0°C to +25°C
ZMOD4450AI3R	ZMOD4450 Sensor Module, 3.0 × 3.0 × 0.9 mm 12-LGA IP67 rating	3	Reel	0°C to +25°C
ZMOD4450AI4V	ZMOD4450 Sensor Module, 3.0 × 3.0 × 0.9 mm 12-LGA IP67 rating, shipped with removable protection sticker	3	Tray	0°C to +25°C
ZMOD4450AI4R	ZMOD4450 Sensor Module, 3.0 × 3.0 × 0.9 mm 12-LGA IP67 rating, shipped with removable protection sticker	3	Reel	0°C to +25°C

Part Number	Description and Package	MSL Rating	Carrier Type	Temperature
ZMOD4450-EVK-HC	ZMOD4450 Evaluation Kit, including the ZMOD4450 Sensor Board, HiCom Communication Board (USB Interface), and Micro-USB Cable. The ZMOD4450 Evaluation Software is available for download free of charge on ZMOD4450 EVK product page.			

15. Revision History

Revision Date	Description of Change
June 30, 2021	<ul style="list-style-type: none"> ▪ Updated improved lifetime ▪ Added a description of firmware and algorithms ▪ Added a marking diagram
December 7, 2020	<ul style="list-style-type: none"> ▪ Updated packaging options ▪ Updated URLs to new Renesas website ▪ Completed minor changes throughout
November 30, 2020	<ul style="list-style-type: none"> ▪ Updated to Renesas branding. ▪ Completed minor changes in wording. ▪ Added ZMOD4450 packages for Assembly Protection and IP67 Rating.
October 30, 2019	<ul style="list-style-type: none"> ▪ MSL rating corrected in the Ordering table. ▪ Product name corrected.
March 7, 2019	<ul style="list-style-type: none"> ▪ Addition of I2C specification. ▪ Revision for URL for software.
December 12, 2018	Initial release.

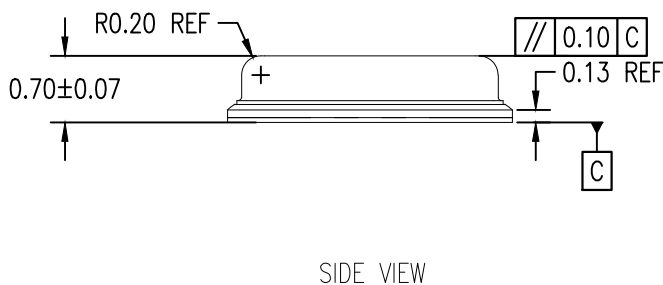
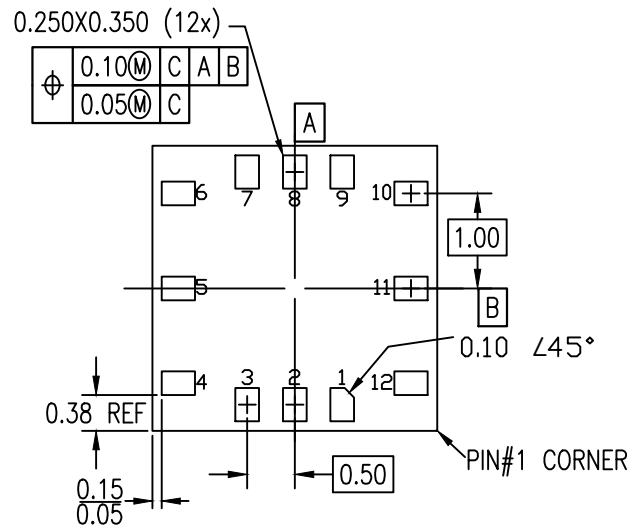
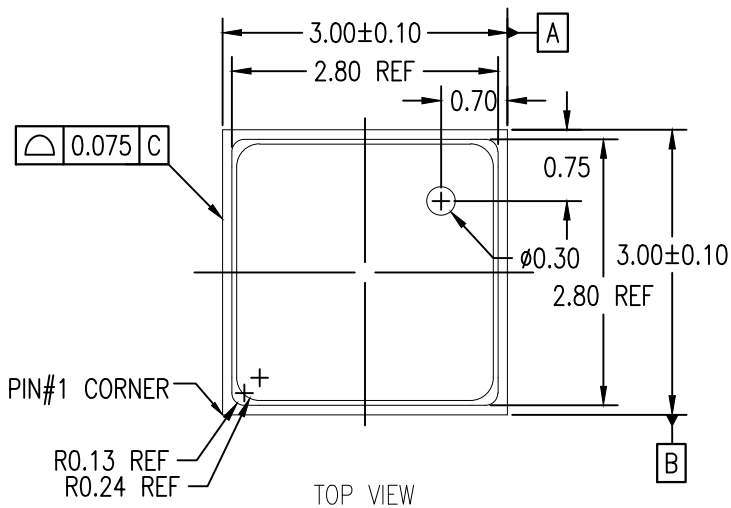

NOTES:

1. ALL DIMENSIONING AND TOLERANCING CONFORM TO ANSI Y14.5M-1982
2. ALL DIMENSION ARE IN MILLIMETERS.
3. UNLESS SPECIFIED, THE TOLERANCE OF ± 0.05 MM APPLIES TO DIMENSIONS OF 2 DECIMALS, AND ± 0.012 MM APPLIES TO DIMENSIONS OF 3 DECIMALS.

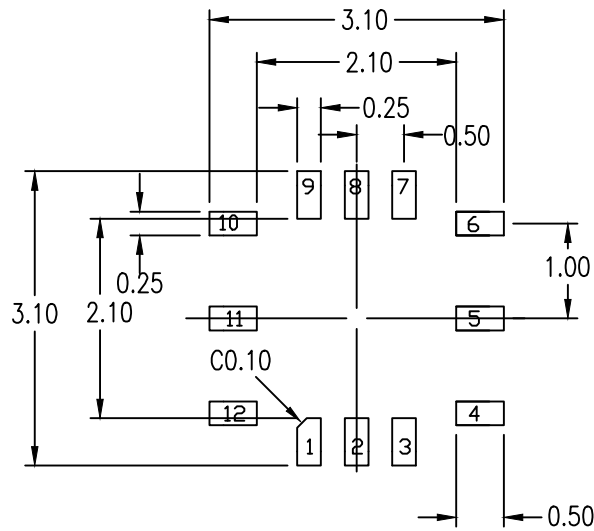

RECOMMENDED LAND PATTERN DIMENSION

NOTES:

1. ALL DIMENSION ARE IN MM. ANGLES IN DEGREES.
2. TOP DOWN VIEW. AS VIEWED ON PCB.
3. NSMD LAND PATTERN ASSUMED.
4. LAND PATTERN RECOMMENDATION PER IPC-7351B GENERIC REQUIREMENT FOR SURFACE MOUNT DESIGN AND LAND PATTERN.

Package Revision History

Date Created	Rev No.	Description
Sept 12, 2019	Rev 01.	Add Dimension on Gal Inlet Hole
Dec 17, 2019	Rev 02	Add Location Dimension Gal Inlet
Mar 10, 2021	Rev 03	Add Tolerance for Entire Body
Apr 27, 2022	Rev 04	Remove PDF SHX
June 20, 2023	Rev 05	Changed body size tolerance to standard tolerance

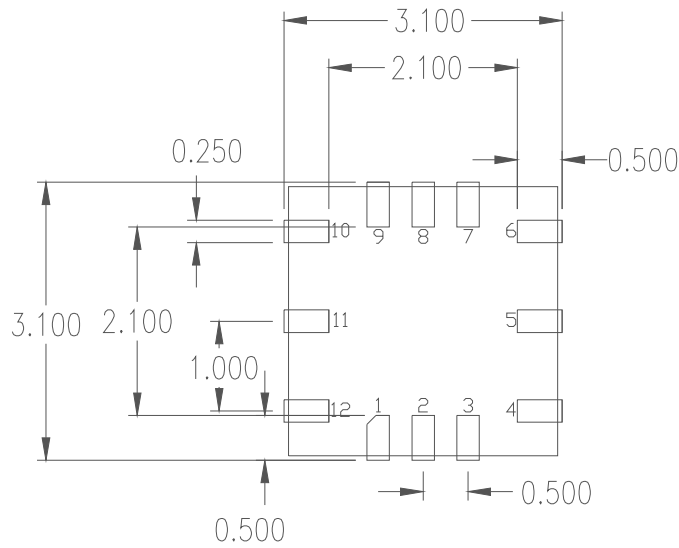

RECOMMENDED LAND PATTERN DIMENSION

NOTES:

1. ALL DIMENSION ARE IN MM. ANGLES IN DEGREES
2. TOP DOWN VIEW ON PCB
3. LAND PATTERN RECOMMENDATION PER IPC-7351B GENERIC REQUIREMENT FOR SURFACE MOUNT DESIGN AND LAND PATTERN

Date Created	Rev No.	Package Revision History
April 24, 2020	Rev 00	Initial release

IMPORTANT NOTICE AND DISCLAIMER

RENESAS ELECTRONICS CORPORATION AND ITS SUBSIDIARIES (“RENESAS”) PROVIDES TECHNICAL SPECIFICATIONS AND RELIABILITY DATA (INCLUDING DATASHEETS), DESIGN RESOURCES (INCLUDING REFERENCE DESIGNS), APPLICATION OR OTHER DESIGN ADVICE, WEB TOOLS, SAFETY INFORMATION, AND OTHER RESOURCES “AS IS” AND WITH ALL FAULTS, AND DISCLAIMS ALL WARRANTIES, EXPRESS OR IMPLIED, INCLUDING, WITHOUT LIMITATION, ANY IMPLIED WARRANTIES OF MERCHANTABILITY, FITNESS FOR A PARTICULAR PURPOSE, OR NON-INFRINGEMENT OF THIRD PARTY INTELLECTUAL PROPERTY RIGHTS.

These resources are intended for developers skilled in the art designing with Renesas products. You are solely responsible for (1) selecting the appropriate products for your application, (2) designing, validating, and testing your application, and (3) ensuring your application meets applicable standards, and any other safety, security, or other requirements. These resources are subject to change without notice. Renesas grants you permission to use these resources only for development of an application that uses Renesas products. Other reproduction or use of these resources is strictly prohibited. No license is granted to any other Renesas intellectual property or to any third party intellectual property. Renesas disclaims responsibility for, and you will fully indemnify Renesas and its representatives against, any claims, damages, costs, losses, or liabilities arising out of your use of these resources. Renesas' products are provided only subject to Renesas' Terms and Conditions of Sale or other applicable terms agreed to in writing. No use of any Renesas resources expands or otherwise alters any applicable warranties or warranty disclaimers for these products.

(Disclaimer Rev.1.0 Mar 2020)

Corporate Headquarters

TOYOSU FORESIA, 3-2-24 Toyosu,
Koto-ku, Tokyo 135-0061, Japan
www.renesas.com

Contact Information

For further information on a product, technology, the most up-to-date version of a document, or your nearest sales office, please visit:
www.renesas.com/contact/

Trademarks

Renesas and the Renesas logo are trademarks of Renesas Electronics Corporation. All trademarks and registered trademarks are the property of their respective owners.