

© - TE Connectivity. All Rights Reserved.

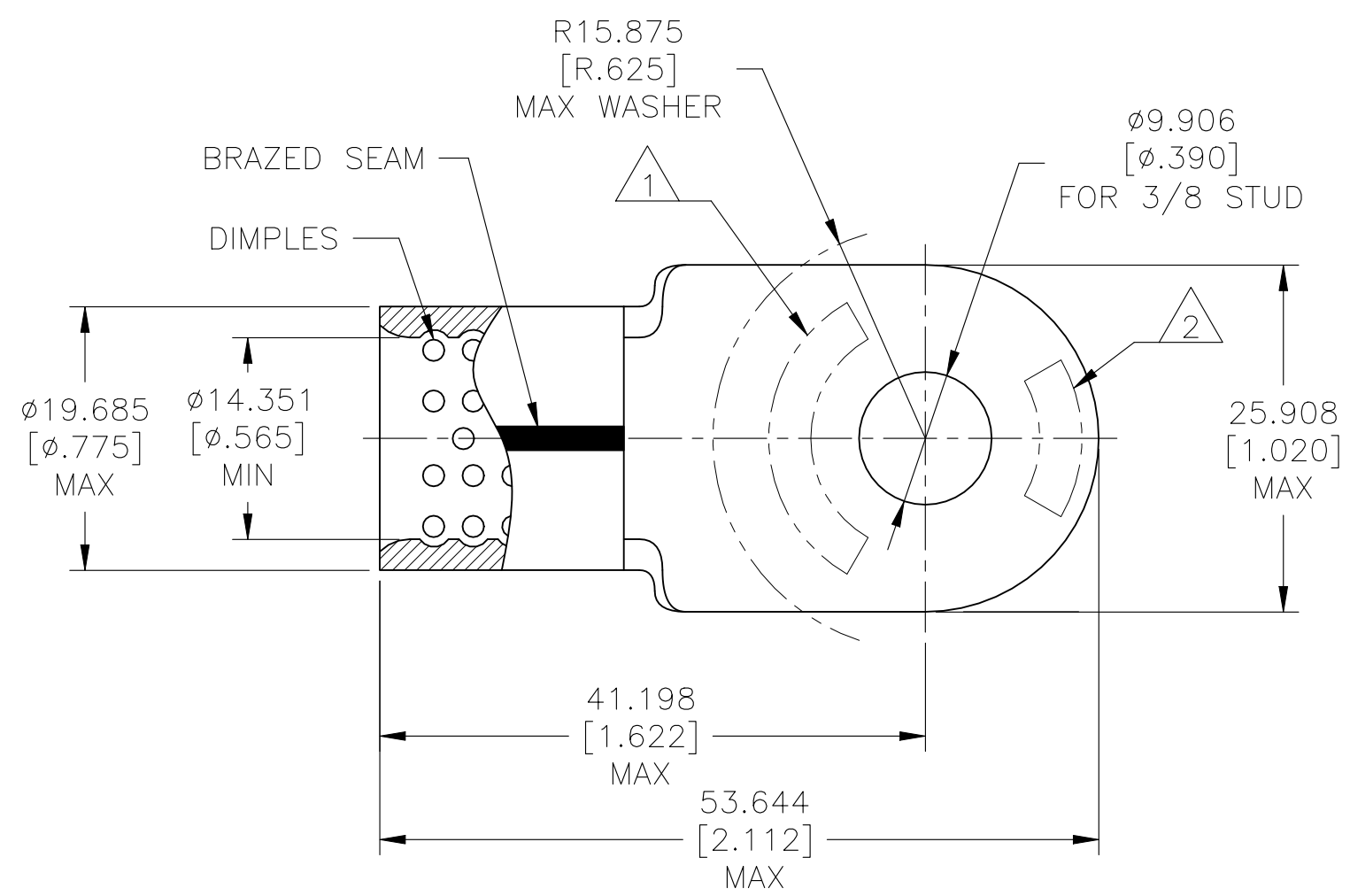



REVISIONS				
P	LTR	DESCRIPTION	DATE	APVD
	F3	REVISED PER ECN-22-150900	27APR2022	RK CSD





AMP WIRE RANGE	 E13288 Listed
3/0 AWG SOLID OR STRANDED	3/0 AWG STRANDED

 LR7189 Certified
3/0 AWG SOLID OR STRANDED

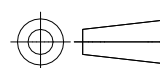

- 1 STAMP AMP 3/0W* APPROX AS SHOWN
- 2 STAMP AMP 150 APPROX AS SHOWN
- 3 MATERIAL THK: 2.311±0.051 [.091±.002]
- 4 TIN PLATE 0.00254 [.000100] MIN. EXT. THK. PER SAE ASTM B545
- 5 NICKEL PLATE 0.00762 [.000300] MIN. EXT. THK. PER AMS QQ-N-290
- 6 NOT UL, CSA OR MILITARY APPROVED. FOR STRANDED WIRE ONLY
- 7 PRODUCT SPECIFICATION UL 486A-B,
- 8 COPPER PER ASTM B152, ANNEALED

		343°C [649°F]	50	LOOSE PIECE	321875-1
		170°C [338°F]	50	LOOSE PIECE	321875
		MAX RECOMMENDED TEMPERATURE	QTY	PACKAGE TYPE	PART NO

AMP INCORPORATED CUSTOMER SERVICE SYSTEMS		MAX RECOMMENDED OPERATING TEMPERATURE: SEE TABLE	THIS DRAWING IS A CONTROLLED DOCUMENT.		DWN DK SCHRUM 5/25/93	 TE Connectivity				
FOR ADDITIONAL PRODUCT INFORMATION OR COPIES OF DRAWINGS AND TECHNICAL DOCUMENTS	PRODUCT INFORMATION CENTER 1-800-522-6752	VOLTAGE RATING: NOT APPLICABLE	DIMENSIONS: mm [INCHES]	TOLERANCES UNLESS OTHERWISE SPECIFIED:	CHK RD HEIM 1/27/94	NAME TERMINAL, RING TONGUE, SOLISTRAND AND STRATO-THERM HR, WIRE SIZE: 3/0 AWG				
FOR APPLICATION TOOLING INFORMATION	TOOLING ASSISTANCE CENTER 1-800-722-1111	WIRE CROSS SECTIONAL AREA RANGE: 76.3-96.3mm ² [150,500-190,000] CIR MILS SOLID OR STRANDED		0 PLC ± - 1 PLC ± - 2 PLC ± - 3 PLC ± 0.127[.005] 4 PLC ± - ANGLES ± -	APVD RE ROSER 1/27/94		SIZE	CAGE CODE	DRAWING NO	RESTRICTED TO
FOR ORDER ENTRY	1-800-526-5142	THIS DRAWING IS A CONTROLLED DOCUMENT FOR AMP INCORPORATED. IT IS SUBJECT TO CHANGE AND THE CONTROLLING ENGINEERING ORGANIZATION SHOULD BE CONTACTED FOR THE LATEST REVISION.	MATERIAL 	FINISH 	PRODUCT SPEC -	APPLICATION SPEC -	WEIGHT -	A3	00779	C-321875
CUSTOMER DRAWING						SCALE	2:1	SHEET	1 OF 1	REV F3