

LOC	DIST	REVISIONS			
P	LTN	DESCRIPTION	DATE	DMN	APVD
A	66	SEE SHEET 1	-	-	-

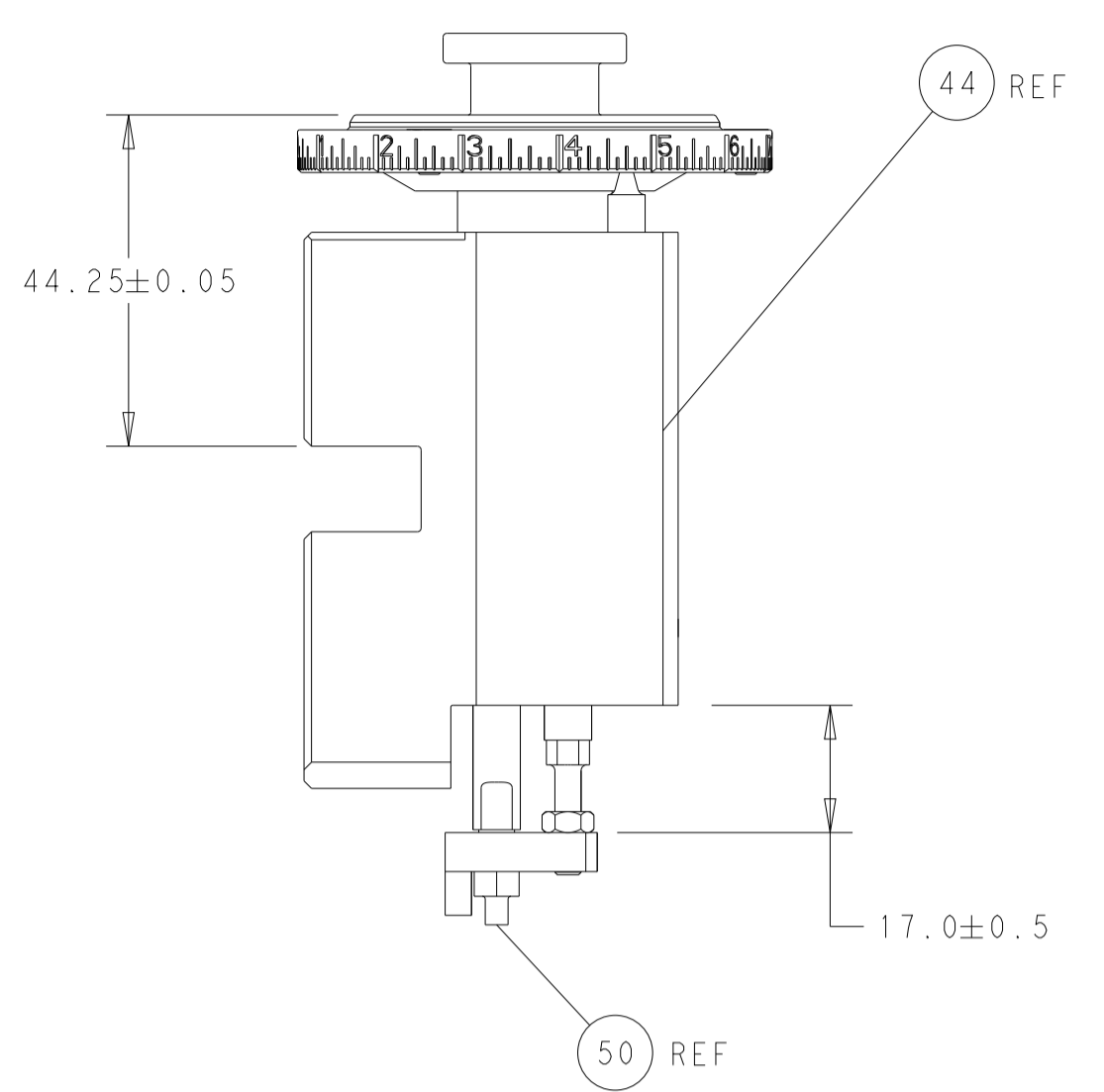

RAM AND HOLDDOWN SET-UP

FEED TYPE

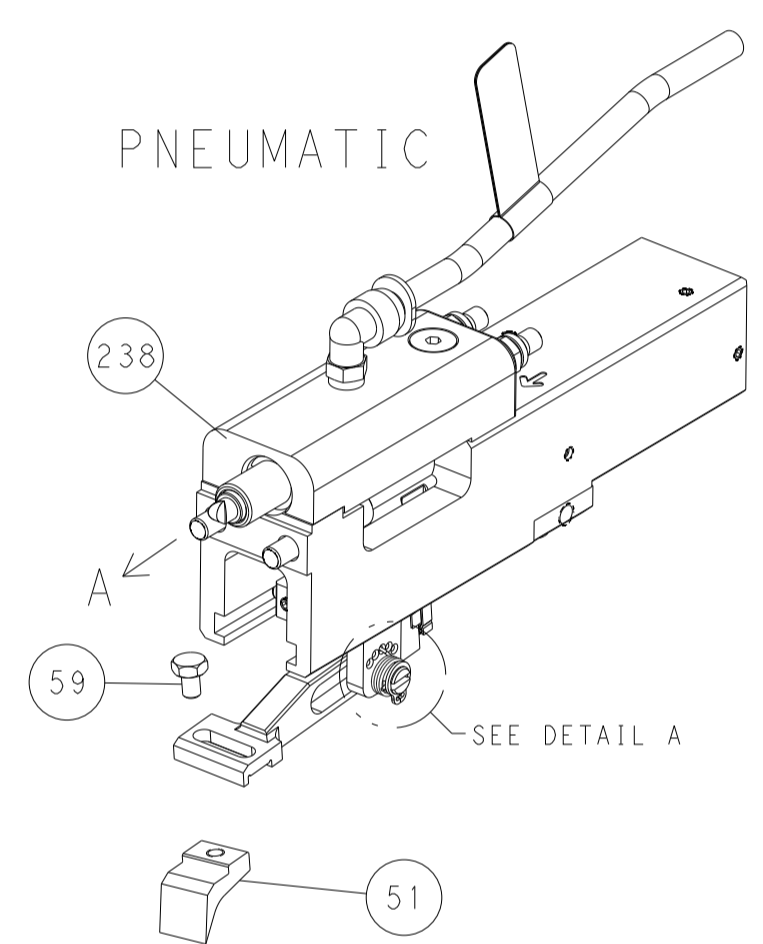
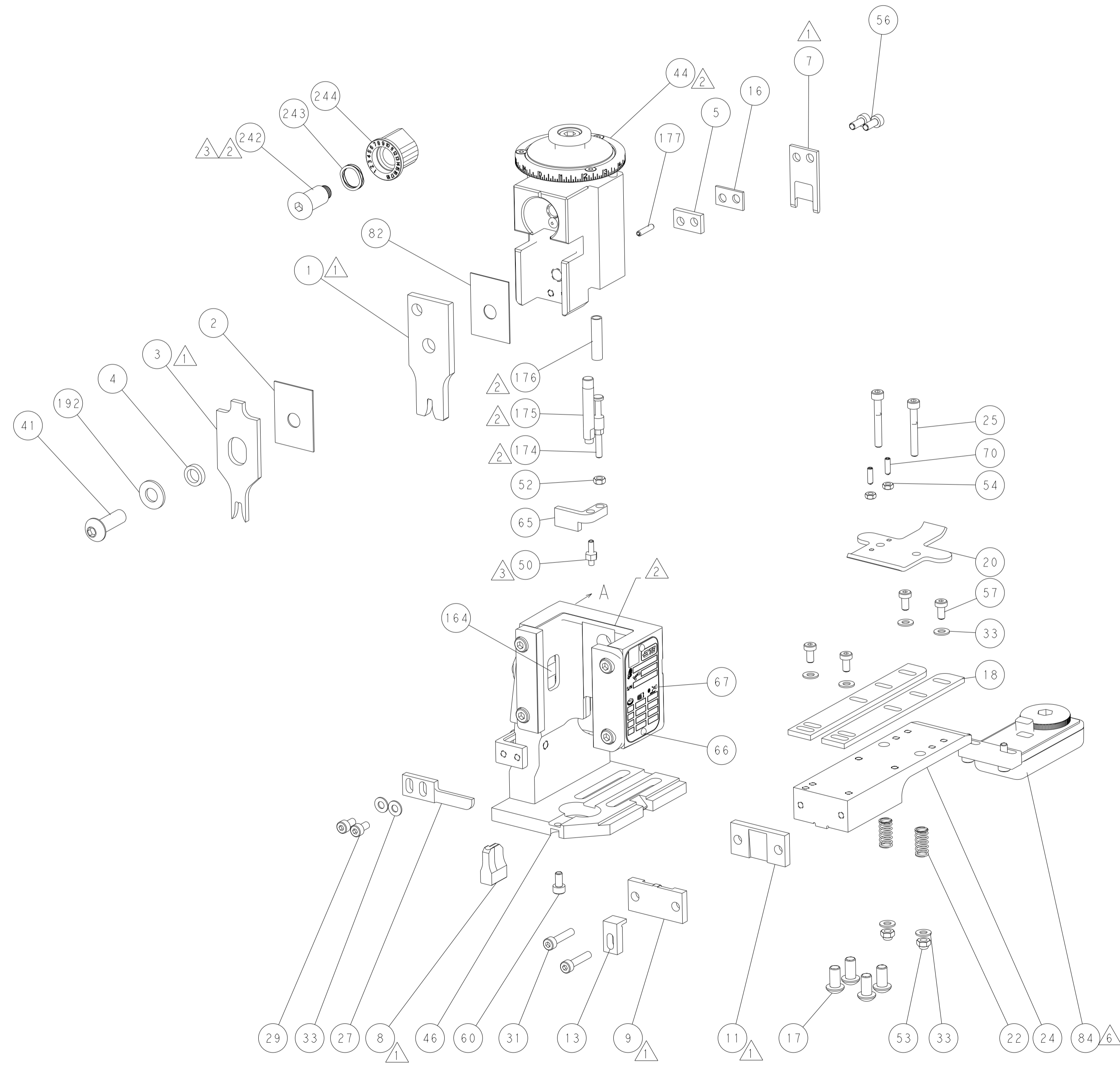

FEED SPRING SETTING POSITION

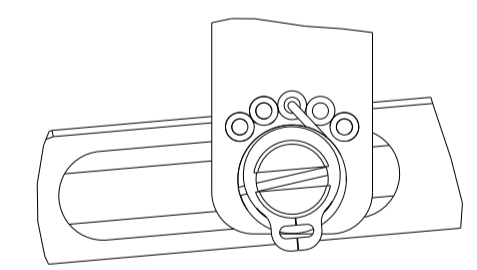

CAM POSITION

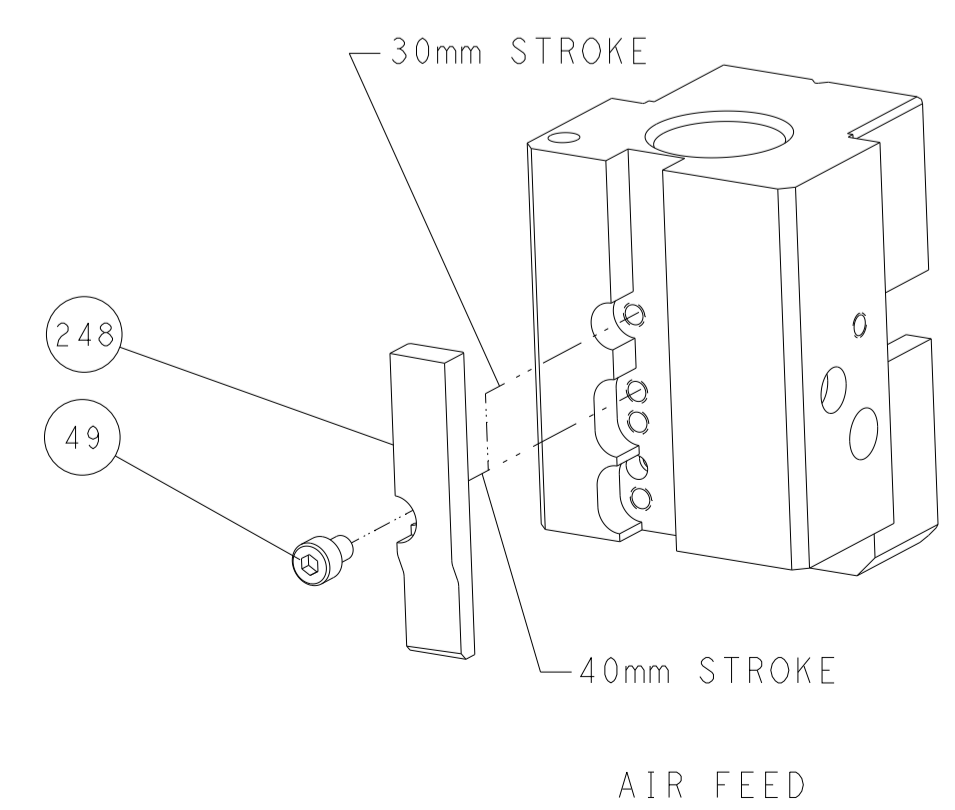

ATLANTIC VERSION
 Shown on sheets 1 of 4 & 2 of 4
 (Pacific version shown on sheets 3 of 4 & 4 of 4)

<small>THIS DRAWING IS UNPUBLISHED. RELEASED FOR PUBLICATION 20. BY TYCO ELECTRONICS CORPORATION. ALL RIGHTS RESERVED.</small>		DWN C. CHEN 05JUL2012 CHK S. XI 05JUL2012 APVD J. CRUZ 05JUL2012	TE Connectivity Harrisburg, PA 17105-3608
DIMENSIONS: mm TOLERANCES UNLESS OTHERWISE SPECIFIED: 0 PLC ± 1 PLC ± 2 PLC ± 3 PLC ± 4 PLC ± ANGLES ° ± FINISH		NAME Ocean End Feed Applicator PRODUCT SPEC APPLICATION SPEC SIZE A1 CAGE CODE 00779 DRAWING NO. C=2150003 WEIGHT SCALE 1:1 SHEET 2 of 4 REV G1	RESTRICTED TO Customer Accessible Production Drawing

PART NUMBER	REVISION	DESCRIPTION	FEED TYPE
2-2150003-2	G	FINE CRIMP HEIGHT ADJUST	PNEUMATIC
7-2150003-7	A	CRIMP TOOLING KIT	-

PACIFIC VERSION TERMINATOR INTERFACE ADAPTER

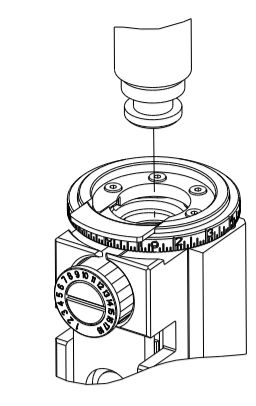

APPLICATOR DATA		
CRIMP	SIZE	TYPE
WIRE	3.05 mm [.120]	F
INSUL	4.57 mm [.180]	F
APPL INSTRUCTIONS 408-35043		

TERMINAL DATA: TE TERMINAL		TE CRIMP SPECIFICATION	
TERMINAL NAME: .250 SERIES FASTON RECEPTACLE			
WIRE STRIP LENGTH		INSULATION DIAMETER RANGE	
6.00-6.80 mm [.236-.268 IN]		Ø4.32-3.05 mm [.170-.120 IN]	
TERMINAL APPLICATION SPECIFICATION	(A)114-2036 (B)114-35000	(D)114-5084	-
TERMINALS APPLIED			
TE TERMINAL	TE TERMINAL	TE TERMINAL	TE TERMINAL
(A) 63537-1	(A) 63537-2	(A) 41202-1	(A) 41274-1
(A) 41274-2	(A) 41274-3	(A) 63655-1	(A) 153377-1
(A) 153377-2	(A) 1217917-2	(A) 63993-1	(B) 61107-1
(D) 170083-2			

TERMINAL DATA: TE TERMINAL		TE CRIMP SPECIFICATION	
TERMINAL NAME: .250 SERIES FASTON RECEPTACLE			
WIRE STRIP LENGTH		INSULATION DIAMETER RANGE	
5.70-6.30 mm [.224-.248 IN]		Ø3.05-4.30 mm [.120-.170 IN]	
TERMINAL APPLICATION SPECIFICATION	(A)114-20023		
TERMINALS APPLIED			
TE TERMINAL	TE TERMINAL	TE TERMINAL	TE TERMINAL
(A) 100570-2			

WIRE SIZE	CRIMP HEIGHT mm [INCH]	CRIMP HEIGHT REFERENCE SETTING
14 AWG OR 2.00mm2	1.91+/-0.05 [.075+/-0.002]	3.6
16 AWG OR 1.25mm2	1.68+/-0.05 [.066+/-0.002]	6.0
18 AWG OR 0.75mm2	1.55+/-0.05 [.061+/-0.002]	7.4

WIRE SIZE	CRIMP HEIGHT mm [INCH]	CRIMP HEIGHT REFERENCE SETTING
2.5 mm2	2.03+/-0.03 [.080+/-0.001]	2.6
2.0 mm2	1.95+/-0.03 [.077+/-0.001]	3.2
1.5 mm2	1.85+/-0.03 [.073+/-0.001]	4.0
1.0 mm2	1.67+/-0.03 [.066+/-0.001]	6.0

- RECOMMENDED SPARE PARTS
- REFER TO SUPPLIED INSTRUCTION SHEET FOR CLEANING, LUBRICATION AND STORAGE OF APPLICATOR.
- APPLY PART NUMBER 1-23419-5 LOCTITE TO THREADS OF ITEM 50. APPLY PART NUMBER 2-23419-6 LOCTITE TO THREADS OF ITEM 242.
- CRIMP HEIGHT REFERENCE SETTING WAS THE SETTING USED WHEN THE APPLICATOR WAS QUALIFIED AT THE FACTORY. ADJUSTMENT MAY BE NECESSARY WHEN RUNNING APPLICATOR IN THE FIELD.
- TERMINAL PITCH NOT COMPATIBLE WITH MECHANICAL FEED.
- TERMINAL LUBRICANT IS RECOMMENDED.

***WARNING**
ON INSTALLATION, SET WIRE DISC TO CRIMP HEIGHT REFERENCE SETTING FOR LARGEST WIRE SIZE. CRIMP HEIGHT REFERENCE SETTINGS GREATER THAN THE VALUE SHOWN MAY CAUSE DAMAGE TO THE CRIMP TOOLING. REFER TO THE INSTRUCTION SHEET FOR PROPER SETUP AND ADJUSTMENTS.

PACIFIC VERSION
Shown on sheets 3 of 4 & 4 of 4
(Atlantic version shown on sheets 1 of 4 & 2 of 4)

LOC	DIST	REVISIONS					
A	66	P	LTN	DESCRIPTION	DATE	OWN	APVD
		-		SEE SHEET 1			

-	1	2119082-9	CAM, SNAIL, INSULATION ADJUSTMENT	244
-	1	2079764-1	WASHER, WAVE SPRING, CREST-TO-CREST	243
-	1	2119083-1	RETAINER, INSULATION DIAL	242
-	1	2844940-3	AIR FEED MODULE	238
-	1	1-18028-0	WASHER, FLAT, REG M8	192
-	4	2079383-9	SCR, BHSC, RoHS (M6 X 20)	186
-	1	6-993111-6	PIN, SLOTTED SPRING 3.0 X 14.0	177
-	1	8-22280-7	SPRING, COMPRESSION	176
-	1	1752353-2	GUIDE PIN,HOLDDOWN	175
-	1	1901680-2	GUIDE PIN,HOLDDOWN	174
-	REF	994970-2	COUNTER, MAGNETIC	164
-	1	2119641-2	FEED CAM, AIR FEED	152
-	1	2168083-8	SCR, SKT HD CAP, RoHS, M4 X 16	144
-	1	2119655-6	APPLICATOR BASIC ASSEMBLY, EF	141
-	1	1803518-1	RAM ASSEMBLY, EF PACIFIC	140
-	1	2119955-2	ASSY, LUBRICATOR, END FEED	84
-	1	455888-5	SPACER, CRIMPER	82
-	1	1803607-4	DOCUMENTATION PACKAGE	71
-	2	2-18032-2	SCR, SET, FLT PNT, M3 X 10.0	70
-	1	2119740-1	TAG, IDENTIFICATION	67
-	2	2168078-1	SCREW, DRIVE, RH, RoHS, 2 x .188	66
-	1	1901681-5	HOLDDOWN, TERMINAL	65
-	1	5-18022-5	SCR, HEX HD CAP, M4 X 6.0	59
-	4	2168400-4	SHCS, LOW HEAD, RoHS, M4 X 8	57
-	2	1-2168083-0	SCR, SKT HD CAP, RoHS, M4 X 10	56
-	2	5018030-1	NUT, HEX, REG, RoHS, M3	54
-	2	986965-8	NUT, LOCK, HEX, TORQUE (M4)	53
-	1	1-5018030-0	NUT, HEX, REG, RoHS, M3.5	52
-	1	2063961-1	FEED FINGER	51
-	1	1-1976055-3	STANDOFF, HOLD-DOWN	50
-	1	18023-9	SCR, SKT HD CAP M4 X 6.0	49
-	1	1803602-1	SCR, BHSC, RoHS (M8 X 25)	41
-	8	1-18028-2	WASHER, FLAT, REG M4	33
-	2	2168083-9	SCR, SKT HD CAP, RoHS, M4 X 20	31
-	2	2168083-2	SCR, SKT HD CAP, RoHS, M4 X 8.0	29
-	1	240639-1	STRIPPER (MACHINING)	27
-	2	1-2168083-5	SCR, SKT HD CAP, RoHS, M4 X 30	25
-	1	1752371-1	PLATE, STRIP GUIDE	24
-	2	2-22281-3	SPRING, COMPRESSION	22
-	1	1803292-4	DRAG	20
-	2	1901259-6	GUIDE, LOWER STRIP	18
-	1	6-240641-4	SPACER	16
-	1	1752360-1	SPACER,HOLD-DOWN	13
-	1	240644-1	PLATE, REAR SHEAR	11
-	-	-	-	10
-	1	690495-6	PLATE, FRONT SHEAR	9
-	1	1338673-2	ANVIL, COMBINATION	8
-	1	5-690474-3	BLADE, SLUG	7
-	1	3-240641-0	SPACER	5
-	1	238011-2	BLOCK, CRIMPER SPACER	4
-	1	2119582-3	CRIMPER, INSULATION F PREMIUM	3
-	1	455888-7	SPACER, CRIMPER	2
-	1	3-456409-6	CRIMPER, WIRE .120 "F" PREMIUM	1

DIMENSIONS:		TOLERANCES UNLESS OTHERWISE SPECIFIED:		MATERIAL:	
mm	0 PLC ±	1 PLC ±	2 PLC ±	3 PLC ±	4 PLC ±
	ANGLES	FINISH			

OWN	CHK	DATE	NAME	SIZE	CAGE CODE	DRAWING NO	RESTRICTED TO
C. CHEN	S. XI	05JUL2012	I. CRUZ	A1	00779	©=2150003	

Customer Accessible Production Drawing SCALE 1:1 SHEET 3 OF 4 REV G1

