

LOC	DATE	REVISIONS	DATE	BY	APP
AA	00				
F		REV PER ECO-11-011343	12OCT2011	TY	KZ
G		ECO-11-013927	28OCT2011	EL	LR

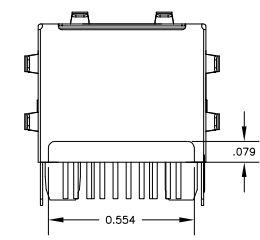
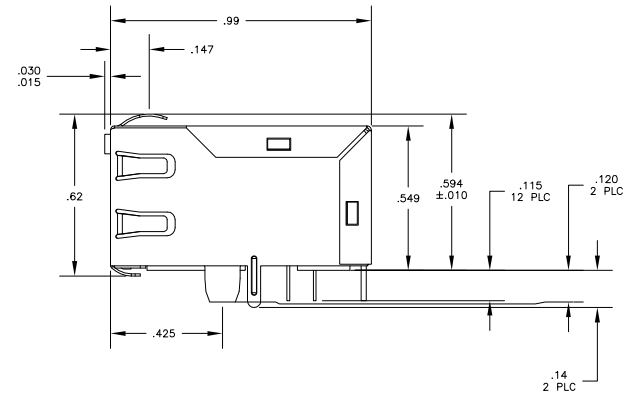
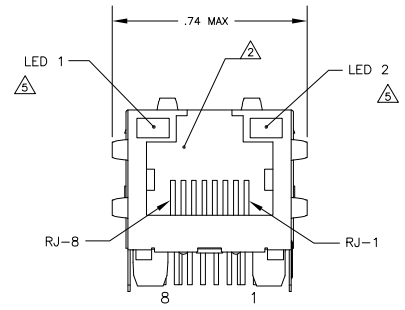
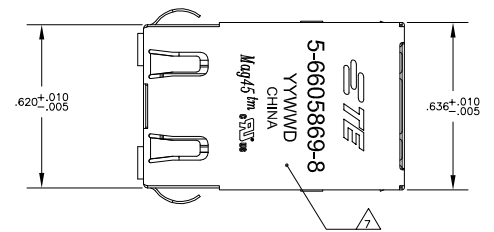

- 1 MATERIALS:  
 HOUSING - THERMOPLASTIC PET POLYESTER FLAMMABILITY RATING UL 94V-0.  
 SHIELD - .008" THICK, C26800 BRASS PREPLATED WITH 30µINCH MIN SEMI-BRIGHT NICKEL; SOLDER TABS POST-DIPPED WITH SAC SOLDER.  
 MOD JACK CONTACTS - .0157" x .018" PHOSPHOR BRONZE, 50µINCH MIN OVERALL NICKEL UNDERPLATE, WITH SELECT 50µINCH MIN HARD GOLD FINISH PLATE. SOLDER TAILS WITH 100µINCH MIN MATTE TIN AND/OR SAC SOLDER DIP.  
 LIGHT EMITTING DIODE(LED) - DIFFUSED EPOXY LENS, .020" x .020" CARBON STEEL WIREFRAME LEADS PREPLATED WITH 80µINCH SILVER OVER 40µINCH NICKEL UNDERPLATE OVER 40µINCH COPPER UNDERPLATE; POST-PLATED WITH 100µINCH MIN MATTE TIN AND/OR SAC SOLDER DIP OR PURE TIN SOLDER DIP.
- 2 RJ45 JACK CAVITY CONFORMS TO FCC RULES AND REGULATIONS PART 68, SUB PART F.
- 3 MAGNETICS  
 -APPLICATION: 10/100 BASE-T  
 -IMPEDANCE: 100 OHMS  
 -TURNS RATIO (CHIP-CABLE): TX = 1:1, RX = 1:1  
 -OPEN CIRCUIT INDUCTANCE (OCL): 350µH MIN @100kHz, 0.1VRMS, 8mADC BIAS FROM 0°C TO 70°C, TX AND RX  
 -PERFORMANCE @ 25°C:  
 INSERTION LOSS (IL): 1.1dB MAX FROM 0.5MHz TO 100MHz  
 RETURN LOSS (RL): 18dB MIN FROM 0.5MHz TO 30MHz  
 18-20LOG(f/30)dB MIN FROM 30.1MHz TO 60MHz  
 12dB MIN FROM 60.1MHz TO 80MHz  
 CROSSTALK ATTENUATION: 35dB MIN FROM 0.5MHz TO 40MHz  
 33-20LOG(f/50)dB MIN FROM 40.1MHz TO 100MHz  
 COMMON MODE REJECTION RATIO (CMRR): 30dB MIN FROM 0.5MHz TO 100MHz  
 -ISOLATION VOLTAGE: 2250VDC (MAX) FOR 60 SECONDS WITH A RISE TIME OF 500V/SEC.
4. OPERATING TEMPERATURE: FROM 0°C TO +70°C.
- 5 LEADS WITHOUT BUILT-IN RESISTOR  
 LEADS ARE DRIVEN WITH CONSTANT CURRENT AT APPROX 20 mA  
 LED COLOR: DOMINANT WAVELENGTH (λD): GREEN 568 nm TYP @ IF=20 mA  
 FORWARD VOLTAGE (VF): GREEN 2.2V TYP @ IF=20 mA  
 DOMINANT WAVELENGTH (λD): YELLOW 588 nm TYP @ IF=20 mA  
 FORWARD VOLTAGE (VF): YELLOW 2.1V TYP @ IF=20 mA
- 6 INDICATED CONNECTIONS ARE FOR NIC CONFIGURATION. THE MAGNETICS ARE SYMMETRIC, AND SUPPORT AUTO-MDI/MDIX.
- 7 TE CONNECTIVITY LOGO, PART NUMBER, DATE CODE, COUNTRY OF ORIGIN AND AGENCY APPROVAL MARKING IN APPROXIMATE LOCATION SHOWN.
8. THESE PARTS ARE RECOMMENDED FOR WAVE SOLDERING PROCESS. PREHEAT TEMPERATURE IS 120°C TO 160°C, 120 SECONDS TO 180 SECONDS, PEAK WAVE SOLDERING TEMPERATURE IS 260°C MAX, 10 SECONDS MAX.

ELECTRICAL:

26P1 MAGNETIC SCHEMATIC:

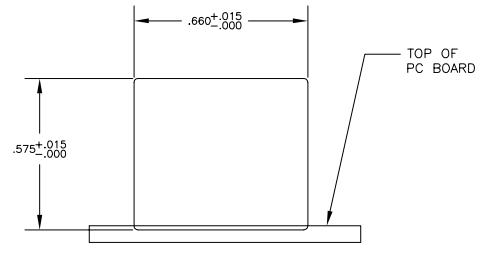
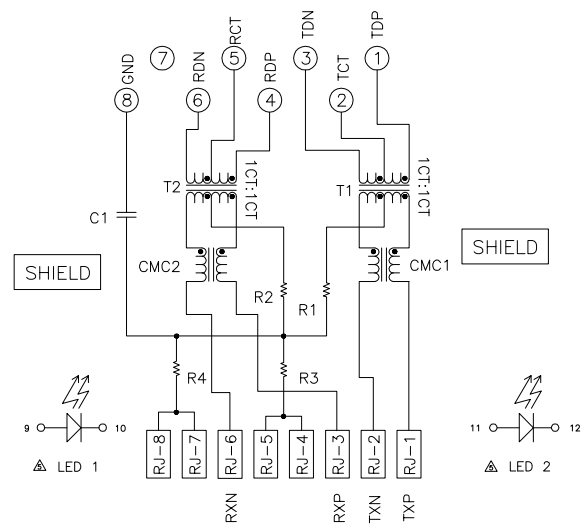

SUGGESTED PANEL CUTOUT

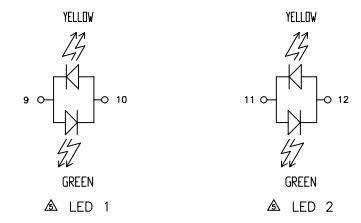

LED CONFIGURATION FOR 6605869-6 ONLY

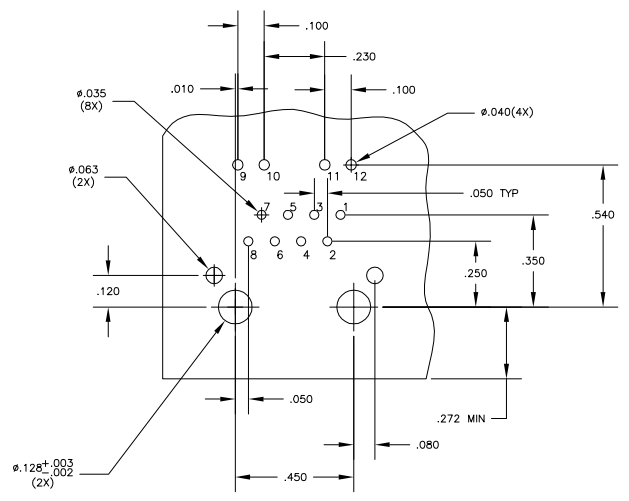

SUGGESTED PC BOARD LAYOUT (Component Side)

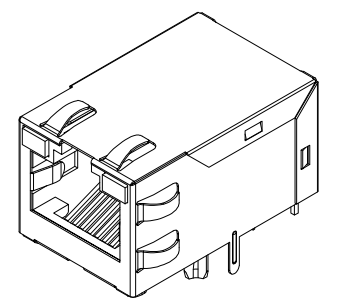

GREEN	YELLOW	5-6605869-8
GREEN	GREEN	5-6605869-7
YELLOW	GREEN	6605869-9
GREEN/YELLOW	GREEN/YELLOW	6605869-6
LED 1	LED 2	PART NUMBER

C1=1000 pF, 2kV CAPACITOR  
 R1-R4 =75 Ohms, 1/16 W RESISTORS

DIMENSIONS:		REV		DATE	
INCHES	NO. DIMENSIONS	BY	DATE	REV	DATE
0.125 ± .003 (2X)	1	J. GILLETTE	28AUG2009	1	
	2	D. FAROLE	31AUG2009	2	
	3	A. FLICKINGER	31AUG2009	3	
	4				
	5				
	6				
	7				
	8				
	9				
	10				
	11				
	12				
	13				
	14				
	15				
	16				
	17				
	18				
	19				
	20				
	21				
	22				
	23				
	24				
	25				
	26				
	27				
	28				
	29				
	30				
	31				
	32				
	33				
	34				
	35				
	36				
	37				
	38				
	39				
	40				
	41				
	42				
	43				
	44				
	45				
	46				
	47				
	48				
	49				
	50				
	51				
	52				
	53				
	54				
	55				
	56				
	57				
	58				
	59				
	60				
	61				
	62				
	63				
	64				
	65				
	66				
	67				
	68				
	69				
	70				
	71				
	72				
	73				
	74				
	75				
	76				
	77				
	78				
	79				
	80				
	81				
	82				
	83				
	84				
	85				
	86				
	87				
	88				
	89				
	90				
	91				
	92				
	93				
	94				
	95				
	96				
	97				
	98				
	99				
	100				