

Features

- ◆ 256K x 16 advanced high-speed CMOS Static RAM
- ◆ JEDEC Center Power / GND pinout for reduced noise.
- ◆ Equal access and cycle times
  - Commercial and Industrial: 10/12/15ns
- ◆ One Chip Select plus one Output Enable pin
- ◆ Bidirectional data inputs and outputs directly LVTTTL-compatible
- ◆ Low power consumption via chip deselect
- ◆ Upper and Lower Byte Enable Pins
- ◆ Single 3.3V power supply
- ◆ Available in 44-pin, 400 mil plastic SOJ package and a 44-pin, 400 mil TSOP Type II package and a 48 ball grid array, 9mm x 9mm package.
- ◆ Green parts available, see ordering information

Description

The IDT71V416 is a 4,194,304-bit high-speed Static RAM organized as 256K x 16. It is fabricated using high-performance, high-reliability CMOS technology. This state-of-the-art technology, combined with innovative circuit design techniques, provides a cost-effective solution for high-speed memory needs.

The IDT71V416 has an output enable pin which operates as fast as 5ns, with address access times as fast as 10ns. All bidirectional inputs and outputs of the IDT71V416 are LVTTTL-compatible and operation is from a single 3.3V supply. Fully static asynchronous circuitry is used, requiring no clocks or refresh for operation.

The IDT71V416 is packaged in a 44-pin, 400 mil Plastic SOJ and a 44-pin, 400 mil TSOP Type II package and a 48 ball grid array, 9mm x 9mm package.

Functional Block Diagram

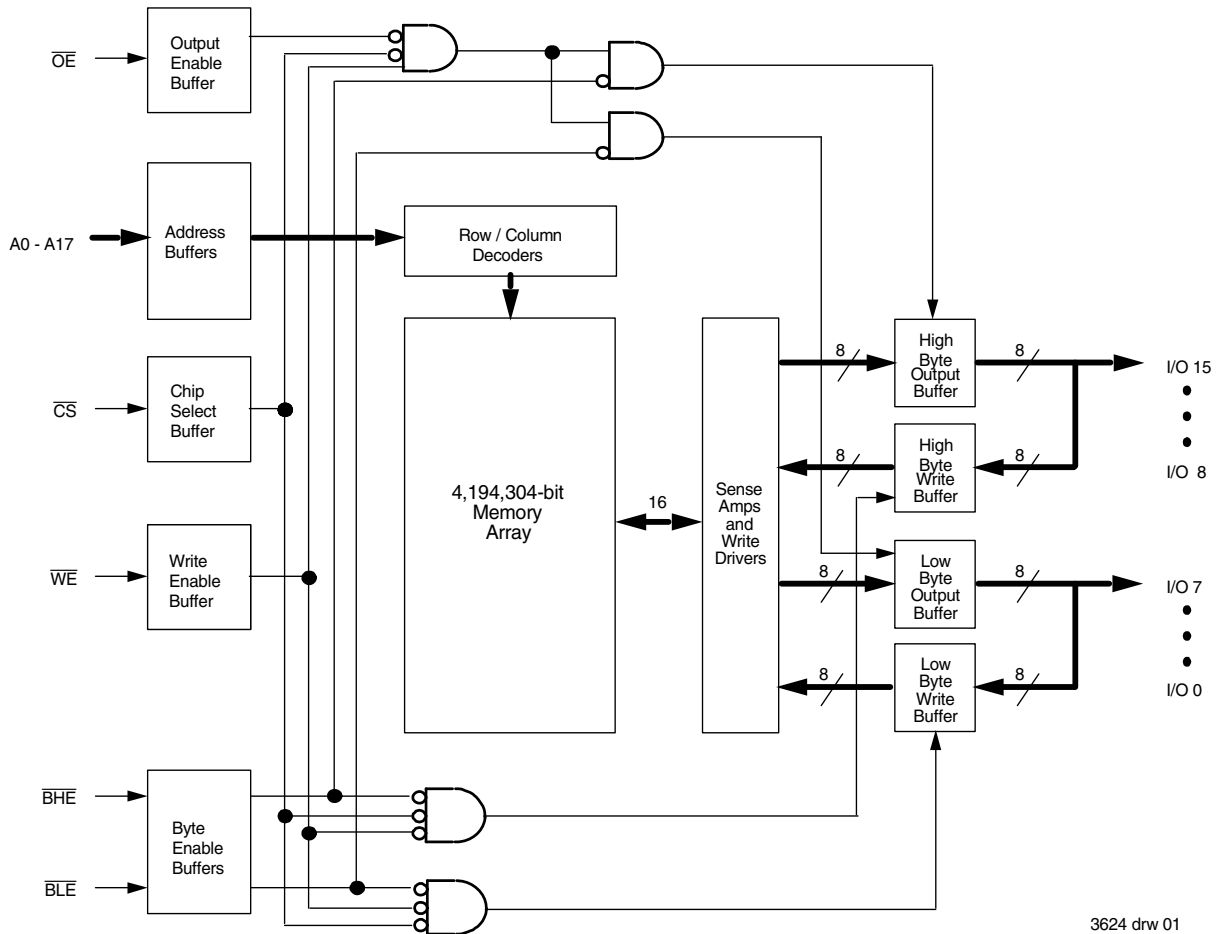

### Pin Configurations - SOJ/TSOP<sup>(2)</sup>

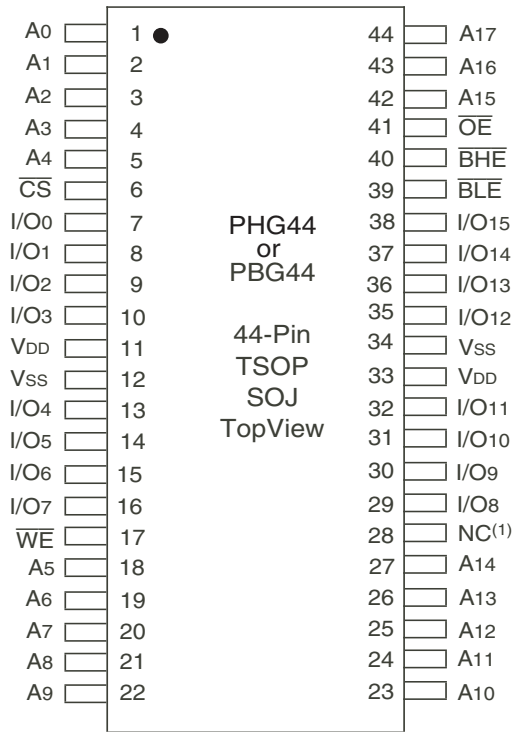

3624 drw 02

**NOTES:**

1. Pin 28 can either be a NC or connected to Vss.
2. This text does not indicate orientation of actual part-marking.

### Pin Descriptions

A0 - A17	Address Inputs	Input
$\overline{CS}$	Chip Select	Input
$\overline{WE}$	Write Enable	Input
$\overline{OE}$	Output Enable	Input
$\overline{BHE}$	High Byte Enable	Input
$\overline{BLE}$	Low Byte Enable	Input
I/O <sub>0</sub> - I/O <sub>15</sub>	Data Input/Output	I/O
V <sub>DD</sub>	3.3V Power	Pwr
V <sub>SS</sub>	Ground	Gnd

3624 tbl 01

### Pin Configurations - BGA<sup>(1)</sup>

BE48, BEG48



3624 tbl 11

### Top View

**NOTE:**

1. This text does not indicate orientation of actual part-marking.

### SOJ Capacitance

(TA = +25°C, f = 1.0MHz)

Symbol	Parameter <sup>(1)</sup>	Conditions	Max.	Unit
C <sub>IN</sub>	Input Capacitance	V <sub>IN</sub> = 3dV	7	pF
C <sub>I/O</sub>	I/O Capacitance	V <sub>OUT</sub> = 3dV	8	pF

3624 tbl 02

### BGA Capacitance

(TA = +25°C, f = 1.0MHz)

Symbol	Parameter <sup>(1)</sup>	Conditions	Max.	Unit
C <sub>IN</sub>	Input Capacitance	V <sub>IN</sub> = 3dV	6	pF
C <sub>I/O</sub>	I/O Capacitance	V <sub>OUT</sub> = 3dV	7	pF

**NOTE:**

1. This parameter is guaranteed by device characterization, but not production tested.

3624 tbl 02b

## Absolute Maximum Ratings<sup>(1)</sup>

Symbol	Rating	Value	Unit
V <sub>DD</sub>	Supply Voltage Relative to V <sub>SS</sub>	-0.5 to +4.6	V
V <sub>IN</sub> , V <sub>OUT</sub>	Terminal Voltage Relative to V <sub>SS</sub>	-0.5 to V <sub>DD</sub> +0.5	V
T <sub>BIAS</sub>	Temperature Under Bias	-55 to +125	°C
T <sub>STG</sub>	Storage Temperature	-55 to +125	°C
P <sub>T</sub>	Power Dissipation	1	W
I <sub>OUT</sub>	DC Output Current	50	mA

3624 tbl 04

### NOTE:

- Stresses greater than those listed under ABSOLUTE MAXIMUM RATINGS may cause permanent damage to the device. This is a stress rating only and functional operation of the device at these or any other conditions above those indicated in the operational sections of this specification is not implied. Exposure to absolute maximum rating conditions for extended periods may affect reliability.

## Recommended Operating Temperature and Supply Voltage

Grade	Temperature	V <sub>SS</sub>	V <sub>DD</sub>
Commercial	0°C to +70°C	0V	See Below
Industrial	-40°C to +85°C	0V	See Below

3624 tbl 05

## Recommended DC Operating Conditions

Symbol	Parameter	Min.	Typ.	Max.	Unit
V <sub>DD</sub>	Supply Voltage	3.0	3.3	3.6	V
V <sub>SS</sub>	Ground	0	0	0	V
V <sub>IH</sub>	Input High Voltage	2.0	—	V <sub>DD</sub> +0.3 <sup>(1)</sup>	V
V <sub>IL</sub>	Input Low Voltage	-0.3 <sup>(2)</sup>	—	0.8	V

3624 tbl 06

### NOTES:

- V<sub>IH</sub> (max.) = V<sub>DD</sub>+2V for pulse width less than 5ns, once per cycle.
- V<sub>IL</sub> (min.) = -2V for pulse width less than 5ns, once per cycle.

## Truth Table<sup>(1)</sup>

$\overline{CS}$	$\overline{OE}$	$\overline{WE}$	$\overline{BLE}$	$\overline{BHE}$	I/O <sub>0</sub> -I/O <sub>7</sub>	I/O <sub>8</sub> -I/O <sub>15</sub>	Function
H	X	X	X	X	High-Z	High-Z	Deselected - Standby
L	L	H	L	H	DATA <sub>OUT</sub>	High-Z	Low Byte Read
L	L	H	H	L	High-Z	DATA <sub>OUT</sub>	High Byte Read
L	L	H	L	L	DATA <sub>OUT</sub>	DATA <sub>OUT</sub>	Word Read
L	X	L	L	L	DATA <sub>IN</sub>	DATA <sub>IN</sub>	Word Write
L	X	L	L	H	DATA <sub>IN</sub>	High-Z	Low Byte Write
L	X	L	H	L	High-Z	DATA <sub>IN</sub>	High Byte Write
L	H	H	X	X	High-Z	High-Z	Outputs Disabled
L	X	X	H	H	High-Z	High-Z	Outputs Disabled

3624 tbl 03

### NOTE:

- H = V<sub>IH</sub>, L = V<sub>IL</sub>, X = Don't care.

## DC Electrical Characteristics

(VDD = Min. to Max., Commercial and Industrial Temperature Ranges)

Symbol	Parameter	Test Conditions	IDT71V416		Unit
			Min.	Max.	
I <sub>LI</sub>	Input Leakage Current	V <sub>CC</sub> = Max., V <sub>IN</sub> = V <sub>SS</sub> to V <sub>DD</sub>	—	5	μA
I <sub>LO</sub>	Output Leakage Current	V <sub>DD</sub> = Max., $\overline{CS} = V_{IH}$ , V <sub>OUT</sub> = V <sub>SS</sub> to V <sub>DD</sub>	—	5	μA
V <sub>OL</sub>	Output Low Voltage	I <sub>OL</sub> = 8mA, V <sub>DD</sub> = Min.	—	0.4	V
V <sub>OH</sub>	Output High Voltage	I <sub>OH</sub> = -4mA, V <sub>DD</sub> = Min.	2.4	—	V

3624 tbl 07

## DC Electrical Characteristics<sup>(1, 2, 3)</sup>

(VDD = Min. to Max., V<sub>LC</sub> = 0.2V, V<sub>HC</sub> = V<sub>DD</sub> - 0.2V)

Symbol	Parameter		71V416S/L10		71V416S/L12		71V416S/L15		Unit
			Com'l.	Ind.	Com'l.	Ind.	Com'l.	Ind.	
I <sub>CC</sub>	Dynamic Operating Current $\overline{CS} \leq V_{LC}$ , Outputs Open, V <sub>DD</sub> = Max., f = f <sub>MAX</sub> <sup>(4)</sup>	S	200	200	180	180	170	170	mA
		L	180	180	170	170	160	160	
I <sub>SB</sub>	Dynamic Standby Power Supply Current $\overline{CS} \geq V_{HC}$ , Outputs Open, V <sub>DD</sub> = Max., f = f <sub>MAX</sub> <sup>(4)</sup>	S	70	70	60	60	50	50	mA
		L	50	50	45	45	40	40	
I <sub>SB1</sub>	Full Standby Power Supply Current (static) $\overline{CS} \geq V_{HC}$ , Outputs Open, V <sub>DD</sub> = Max., f = 0 <sup>(4)</sup>	S	20	20	20	20	20	20	mA
		L	10	10	10	10	10	10	

3624 tbl 08

NOTES:

- All values are maximum guaranteed values.
- All inputs switch between 0.2V (Low) and V<sub>DD</sub> - 0.2V (High).
- Power specifications are preliminary.
- f<sub>MAX</sub> = 1/trc (all address inputs are cycling at f<sub>MAX</sub>); f = 0 means no address input lines are changing.

**IDT71V416S/71V416L**

## AC Test Loads

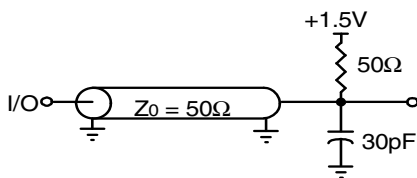

3624 drw 03

Figure 1. AC Test Load

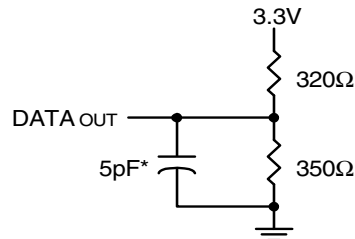

3624 drw 04

\*Including jig and scope capacitance.

Figure 2. AC Test Load  
(for t<sub>OLZ</sub>, t<sub>OLZ</sub>, t<sub>CHZ</sub>, t<sub>CHZ</sub>, t<sub>OW</sub>, and t<sub>WHZ</sub>)

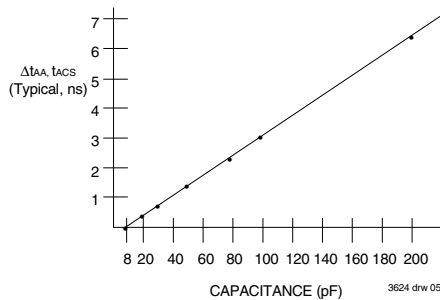

3624 drw 05

Figure 3. Output Capacitive Derating

## AC Test Conditions

Input Pulse Levels	GND to 3.0V
Input Rise/Fall Times	1.5ns
Input Timing Reference Levels	1.5V
Output Reference Levels	1.5V
AC Test Load	Figures 1,2 and 3

3624 tbl 09

## AC Electrical Characteristics

(VDD = Min. to Max., Commercial and Industrial Temperature Ranges)

Symbol	Parameter	71V416S/L10		71V416S/L12		71V416S/L15		Unit
		Min.	Max.	Min.	Max.	Min.	Max.	
<b>READ CYCLE</b>								
t <sub>RC</sub>	Read Cycle Time	10	—	12	—	15	—	ns
t <sub>AA</sub>	Address Access Time	—	10	—	12	—	15	ns
t <sub>ACS</sub>	Chip Select Access Time	—	10	—	12	—	15	ns
t <sub>CLZ</sub> <sup>(1)</sup>	Chip Select Low to Output in Low-Z	4	—	4	—	4	—	ns
t <sub>CHZ</sub> <sup>(1)</sup>	Chip Select High to Output in High-Z	—	5	—	6	—	7	ns
t <sub>OE</sub>	Output Enable Low to Output Valid	—	5	—	6	—	7	ns
t <sub>OLZ</sub> <sup>(1)</sup>	Output Enable Low to Output in Low-Z	0	—	0	—	0	—	ns
t <sub>OHZ</sub> <sup>(1)</sup>	Output Enable High to Output in High-Z	—	5	—	6	—	7	ns
t <sub>OH</sub>	Output Hold from Address Change	4	—	4	—	4	—	ns
t <sub>BE</sub>	Byte Enable Low to Output Valid	—	5	—	6	—	7	ns
t <sub>BLZ</sub> <sup>(1)</sup>	Byte Enable Low to Output in Low-Z	0	—	0	—	0	—	ns
t <sub>BHZ</sub> <sup>(1)</sup>	Byte Enable High to Output in High-Z	—	5	—	6	—	7	ns
<b>WRITE CYCLE</b>								
t <sub>WC</sub>	Write Cycle Time	10	—	12	—	15	—	ns
t <sub>AW</sub>	Address Valid to End of Write	8	—	8	—	10	—	ns
t <sub>CW</sub>	Chip Select Low to End of Write	8	—	8	—	10	—	ns
t <sub>BW</sub>	Byte Enable Low to End of Write	8	—	8	—	10	—	ns
t <sub>AS</sub>	Address Set-up Time	0	—	0	—	0	—	ns
t <sub>WR</sub>	Address Hold from End of Write	0	—	0	—	0	—	ns
t <sub>WP</sub>	Write Pulse Width	8	—	8	—	10	—	ns
t <sub>DW</sub>	Data Valid to End of Write	5	—	6	—	7	—	ns
t <sub>DH</sub>	Data Hold Time	0	—	0	—	0	—	ns
t <sub>OW</sub> <sup>(1)</sup>	Write Enable High to Output in Low-Z	3	—	3	—	3	—	ns
t <sub>WHZ</sub> <sup>(1)</sup>	Write Enable Low to Output in High-Z	—	6	—	7	—	7	ns

3624 tbl 10

NOTE:

1. This parameter is guaranteed with the AC Load (Figure 2) by device characterization, but is not production tested.

### Timing Waveform of Read Cycle No. 1 (1,2,3)

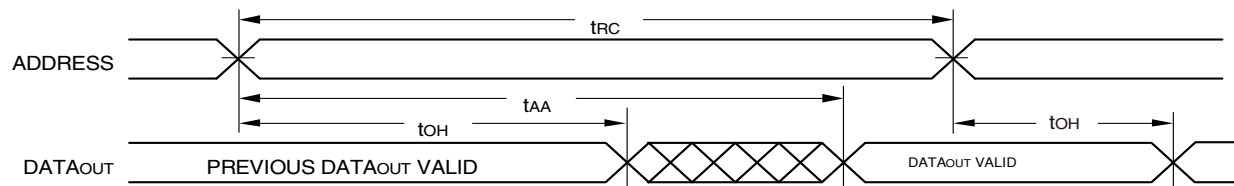

3624 drw 06

NOTES:

1.  $\overline{WE}$  is HIGH for Read Cycle.
2. Device is continuously selected,  $\overline{CS}$  is LOW.
3.  $\overline{OE}$ ,  $\overline{BHE}$ , and  $\overline{BLE}$  are LOW.

## Timing Waveform of Read Cycle No. 2<sup>(1)</sup>

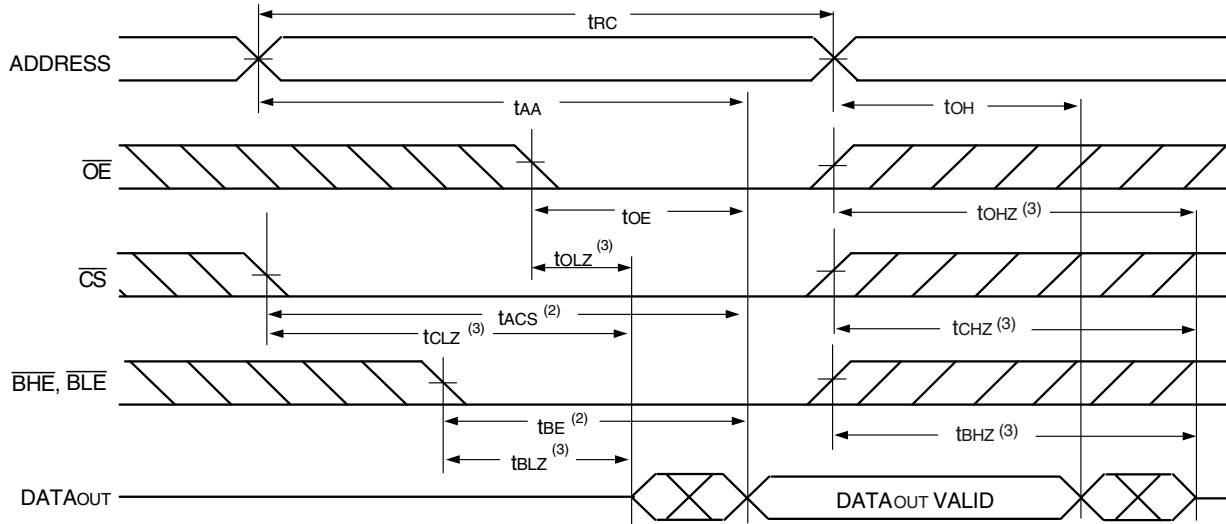

3624 drw 07

NOTES:

1.  $\overline{WE}$  is HIGH for Read Cycle.
2. Address must be valid prior to or coincident with the later of  $\overline{CS}$ ,  $\overline{BHE}$ , or  $\overline{BLE}$  transition LOW; otherwise  $t_{AA}$  is the limiting parameter.
3. Transition is measured  $\pm 200\text{mV}$  from steady state.

## Timing Waveform of Write Cycle No. 1 ( $\overline{WE}$ Controlled Timing)<sup>(1,2,4)</sup>

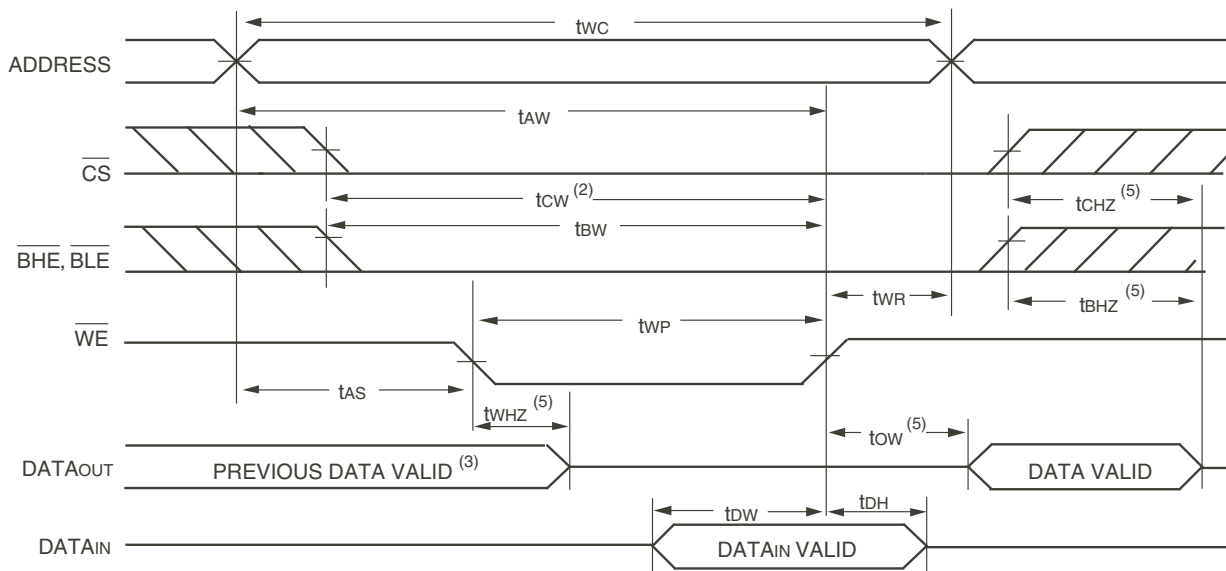

3624 drw 08

NOTES:

1. A write occurs during the overlap of a LOW  $\overline{CS}$ , LOW  $\overline{BHE}$  or  $\overline{BLE}$ , and a LOW  $\overline{WE}$ .
2.  $\overline{OE}$  is continuously HIGH. If during a  $\overline{WE}$  controlled write cycle  $\overline{OE}$  is LOW,  $t_{WP}$  must be greater than or equal to  $t_{WHZ} + t_{DW}$  to allow the I/O drivers to turn off and data to be placed on the bus for the required  $t_{DW}$ . If  $\overline{OE}$  is HIGH during a  $\overline{WE}$  controlled write cycle, this requirement does not apply and the minimum write pulse is as short as the specified  $t_{WP}$ .
3. During this period, I/O pins are in the output state, and input signals must not be applied.
4. If the  $\overline{CS}$  LOW or  $\overline{BHE}$  and  $\overline{BLE}$  LOW transition occurs simultaneously with or after the  $\overline{WE}$  LOW transition, the outputs remain in a high-impedance state.
5. Transition is measured  $\pm 200\text{mV}$  from steady state.

### Timing Waveform of Write Cycle No. 2 ( $\overline{\text{CS}}$ Controlled Timing)<sup>(1,3)</sup>

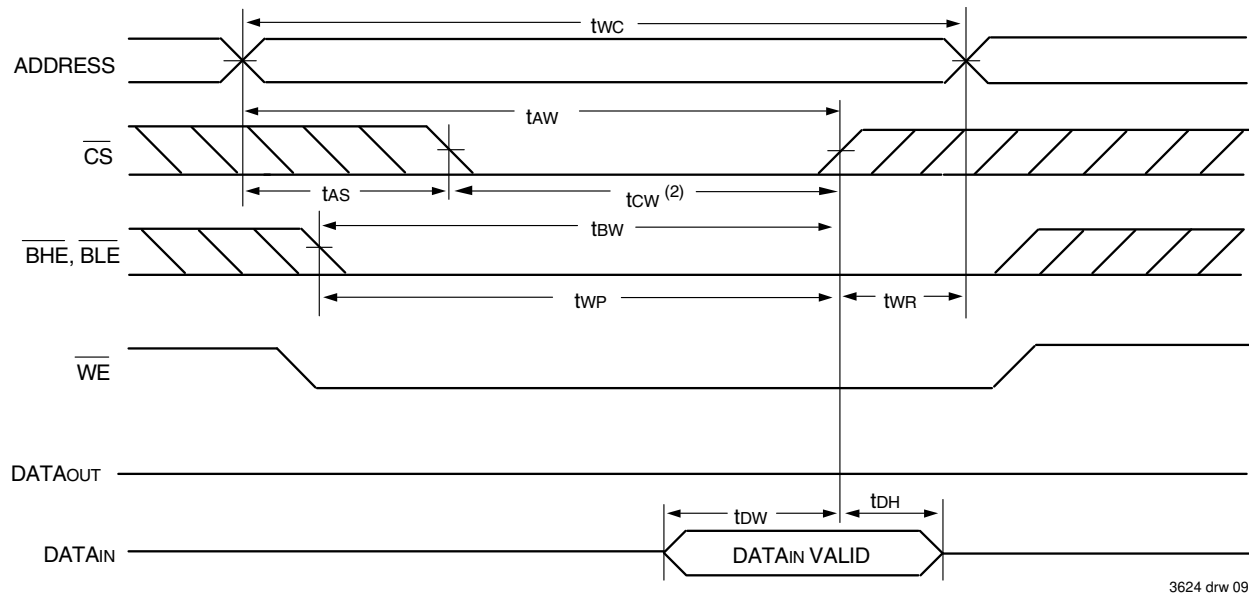

### Timing Waveform of Write Cycle No. 3 ( $\overline{\text{BHE}}$ , $\overline{\text{BLE}}$ Controlled Timing)<sup>(1,3)</sup>

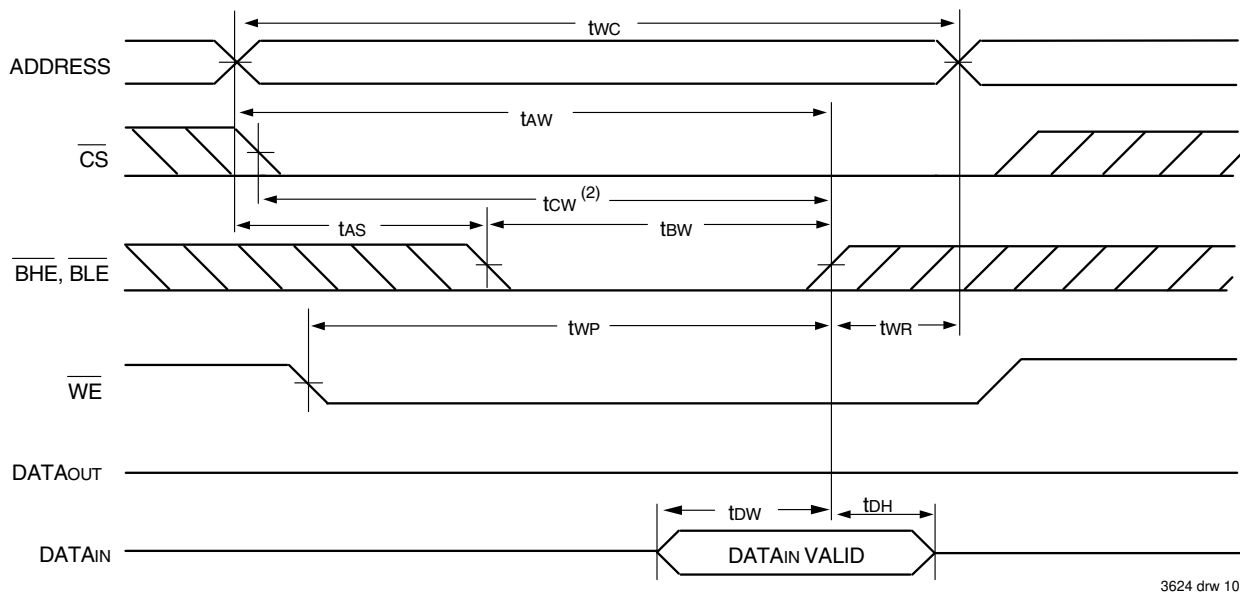

NOTES:

1. A write occurs during the overlap of a LOW  $\overline{\text{CS}}$ , LOW  $\overline{\text{BHE}}$  or  $\overline{\text{BLE}}$ , and a LOW  $\overline{\text{WE}}$ .
2. During this period, I/O pins are in the output state, and input signals must not be applied.
3. If the  $\overline{\text{CS}}$  LOW or  $\overline{\text{BHE}}$  and  $\overline{\text{BLE}}$  LOW transition occurs simultaneously with or after the  $\overline{\text{WE}}$  LOW transition, the outputs remain in a high-impedance state.

## Ordering Information

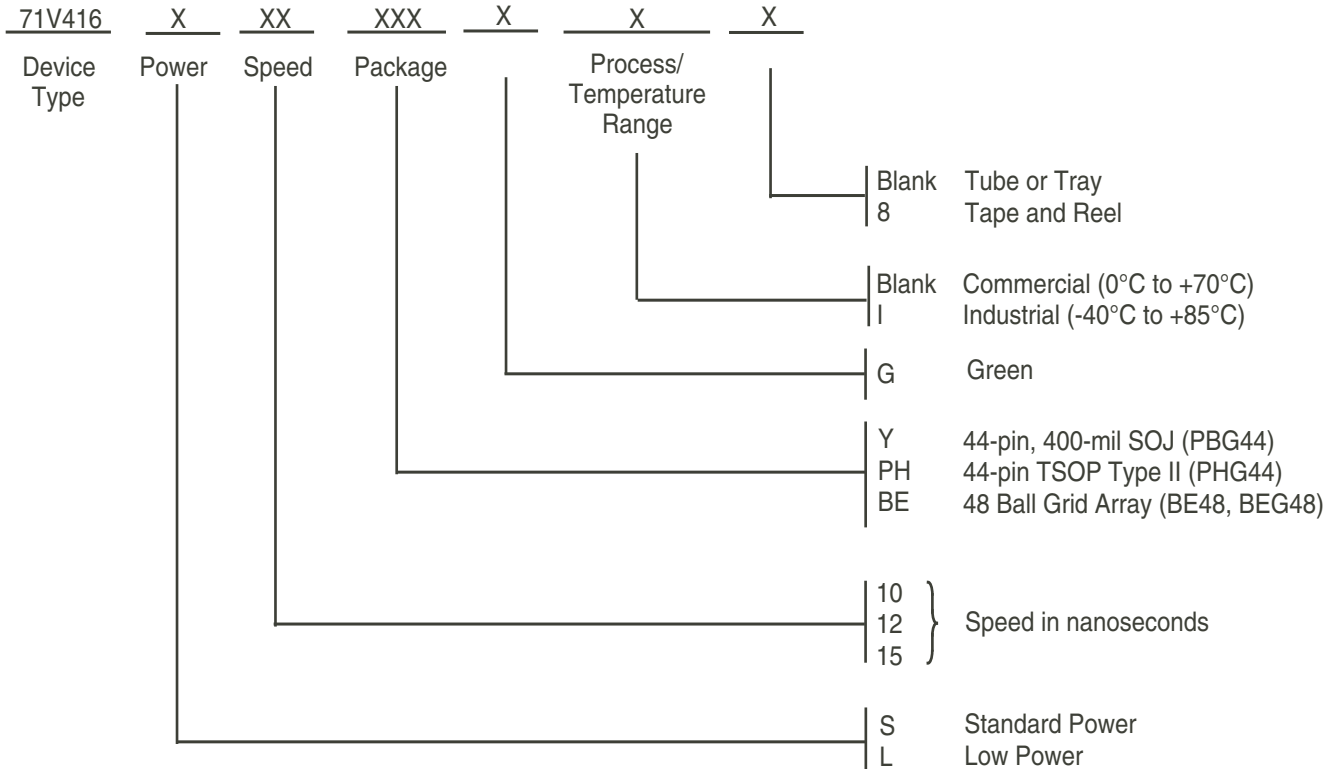

## Orderable Part Information

3624 drw 11a

Speed (ns)	Orderable Part ID	Pkg. Code	Pkg. Type	Temp. Grade
10	71V416L10BE	BE48	CABGA	C
	71V416L10BEG	BEG48	CABGA	C
	71V416L10BEG8	BEG48	CABGA	C
	71V416L10PHG	PHG44	TSOP	C
	71V416L10PHG8	PHG44	TSOP	C
	71V416L10PHGI	PHG44	TSOP	I
	71V416L10PHGI8	PHG44	TSOP	I
	71V416L10YG	PBG44	SOJ	C
	71V416L10YG8	PBG44	SOJ	C
12	71V416L12BE	BE48	CABGA	C
	71V416L12BE8	BE48	CABGA	C
	71V416L12BEG	BEG48	CABGA	C
	71V416L12BEG8	BEG48	CABGA	C
	71V416L12BEGI	BEG48	CABGA	I
	71V416L12BEGI8	BEG48	CABGA	I
	71V416L12BEI	BE48	CABGA	I
	71V416L12BEI8	BE48	CABGA	I
	71V416L12PHG	PHG44	TSOP	C
	71V416L12PHG8	PHG44	TSOP	C
	71V416L12PHGI	PHG44	TSOP	I
	71V416L12PHGI8	PHG44	TSOP	I
	71V416L12YG	PBG44	SOJ	C
	71V416L12YG8	PBG44	SOJ	C
	71V416L12YGI	PBG44	SOJ	I
	71V416L12YGI8	PBG44	SOJ	I

3624 tbl 12a

Speed (ns)	Orderable Part ID	Pkg. Code	Pkg. Type	Temp. Grade	
10	71V416S10BE	BE48	CABGA	C	
	71V416S10BE8	BE48	CABGA	C	
	71V416S10BEG	BEG48	CABGA	C	
	71V416S10BEG8	BEG48	CABGA	C	
	71V416S10PHG	PHG44	TSOP	C	
	71V416S10PHG8	PHG44	TSOP	C	
	71V416S10PHGI	PHG44	TSOP	I	
	71V416S10PHGI8	PHG44	TSOP	I	
	71V416S10YG	PBG44	SOJ	C	
	71V416S10YG8	PBG44	SOJ	C	
	12	71V416S12BE	BE48	CABGA	C
		71V416S12BE8	BE48	CABGA	C
71V416S12BEG		BEG48	CABGA	C	
71V416S12BEG8		BEG48	CABGA	C	
71V416S12BEGI		BE48	CABGA	I	
71V416S12BEI8		BE48	CABGA	I	
71V416S12PHG		PHG44	TSOP	C	
71V416S12PHG8		PHG44	TSOP	C	
71V416S12PHGI		PHG44	TSOP	I	
71V416S12PHGI8		PHG44	TSOP	I	
71V416S12YG		PBG44	SOJ	C	
71V416S12YG8		PBG44	SOJ	C	
71V416S12YGI	PBG44	SOJ	I		
71V416S12YGI8	PBG44	SOJ	I		

3624 tbl 12b



## Orderable Part Information (con't)

Speed (ns)	Orderable Part ID	Pkg. Code	Pkg. Type	Temp. Grade
15	71V416L15BE	BE48	CABGA	C
	71V416L15BE8	BE48	CABGA	C
	71V416L15BEG	BEG48	CABGA	C
	71V416L15BEG8	BEG48	CABGA	C
	71V416L15BEGI	BEG48	CABGA	I
	71V416L15BEGI8	BEG48	CABGA	I
	71V416L15BEI	BE48	CABGA	I
	71V416L15BEI8	BE48	CABGA	I
	71V416L15PHG	PHG44	TSOP	C
	71V416L15PHG8	PHG44	TSOP	C
	71V416L15PHGI	PHG44	TSOP	I
	71V416L15PHGI8	PHG44	TSOP	I
	71V416L15YGI	PBG44	SOJ	I
	71V416L15YGI8	PBG44	SOJ	I

3624 tbl 12c

Speed (ns)	Orderable Part ID	Pkg. Code	Pkg. Type	Temp. Grade
15	71V416S15BE	BE48	CABGA	C
	71V416S15BE8	BE48	CABGA	C
	71V416S15BEG	BEG48	CABGA	C
	71V416S15BEG8	BEG48	CABGA	C
	71V416S15BEGI	BEG48	CABGA	I
	71V416S15BEGI8	BEG48	CABGA	I
	71V416S15BEI	BE48	CABGA	I
	71V416S15BEI8	BE48	CABGA	I
	71V416S15PHG	PHG44	TSOP	C
	71V416S15PHG8	PHG44	TSOP	C
	71V416S15PHGI	PHG44	TSOP	I
	71V416S15PHGI8	PHG44	TSOP	I
	71V416S15YG	PBG44	SOJ	C
	71V416S15YG8	PBG44	SOJ	C
	71V416S15YGI	PBG44	SOJ	I
	71V416S15YGI8	PBG44	SOJ	I

3624 tbl 12d

## Datasheet Document History

08/05/99:		Updated to new format
	Pg 6	Revised footnote for tcw on Write Cycle No. 1 diagram
08/31/99:	Pg. 1–9	Added Industrial temperature range offering
	Pg. 9	Added Datasheet Document History
03/24/00:	Pg. 6	Changed note to Write cycle No. 1 according to footnotes
08/10/00:		Add 48 ball grid array package offering
	Pg. 1	Correct TTL to LVTTTL
09/11/02:	Pg. 2	Updated TBD information for the 48 BGA Capacitance table
11/26/02:	Pg. 8	Added "Die Revision" to ordering information
07/31/03:	Pg. 8	Updated note, L10 speed grade commercial temperature only and updated die stepping from YF to Y.
10/13/03:	Pg. 8	Updated ordering information. Refer to 71V416YS and 71V416YL datasheet for latest generation die step.
01/30/04:	Pg. 8	Added "Restricted hazardous substance device" to ordering information
02/01/13:	Pg. 1	Removed IDT reference to fabrication
	Pg. 8	Removed die revision information from the Ordering Information
11/18/16:	Pg. 2	Updated the orderable part numbers for all pin configurations
		Added the corrected configuration title for the 48 BGA pin configuration
		Reformatted SOJ/TSOP pins & labels. No change in functionality. It remains the same
	Pg.4	Updated the Industrial values and the footnote references in the DC Electrical table
	Pg. 5	Updated the footnote references in the AC Electrical table
	Pg. 8	Updated the orderable part numbers in the Ordering Information
	Pg. 8-9	Added orderable part information tables
05/26/21:	Pg. 1 - 10	Rebranded as Renesas datasheet
	Pg. 2 & 8	Updated package codes

## IMPORTANT NOTICE AND DISCLAIMER

RENESAS ELECTRONICS CORPORATION AND ITS SUBSIDIARIES (“RENESAS”) PROVIDES TECHNICAL SPECIFICATIONS AND RELIABILITY DATA (INCLUDING DATASHEETS), DESIGN RESOURCES (INCLUDING REFERENCE DESIGNS), APPLICATION OR OTHER DESIGN ADVICE, WEB TOOLS, SAFETY INFORMATION, AND OTHER RESOURCES “AS IS” AND WITH ALL FAULTS, AND DISCLAIMS ALL WARRANTIES, EXPRESS OR IMPLIED, INCLUDING, WITHOUT LIMITATION, ANY IMPLIED WARRANTIES OF MERCHANTABILITY, FITNESS FOR A PARTICULAR PURPOSE, OR NON-INFRINGEMENT OF THIRD PARTY INTELLECTUAL PROPERTY RIGHTS.

These resources are intended for developers skilled in the art designing with Renesas products. You are solely responsible for (1) selecting the appropriate products for your application, (2) designing, validating, and testing your application, and (3) ensuring your application meets applicable standards, and any other safety, security, or other requirements. These resources are subject to change without notice. Renesas grants you permission to use these resources only for development of an application that uses Renesas products. Other reproduction or use of these resources is strictly prohibited. No license is granted to any other Renesas intellectual property or to any third party intellectual property. Renesas disclaims responsibility for, and you will fully indemnify Renesas and its representatives against, any claims, damages, costs, losses, or liabilities arising out of your use of these resources. Renesas' products are provided only subject to Renesas' Terms and Conditions of Sale or other applicable terms agreed to in writing. No use of any Renesas resources expands or otherwise alters any applicable warranties or warranty disclaimers for these products.

(Disclaimer Rev.1.0 Mar 2020)

### Corporate Headquarters

TOYOSU FORESIA, 3-2-24 Toyosu,  
Koto-ku, Tokyo 135-0061, Japan  
[www.renesas.com](http://www.renesas.com)

### Contact Information

For further information on a product, technology, the most up-to-date version of a document, or your nearest sales office, please visit:  
[www.renesas.com/contact/](http://www.renesas.com/contact/)

### Trademarks

Renesas and the Renesas logo are trademarks of Renesas Electronics Corporation. All trademarks and registered trademarks are the property of their respective owners.