

High-Voltage Input Integrated Switch Step-Down Regulator

Features

- Up to 96% Efficiency
- Input Voltage Range: 4.4V to 50V
- Output Voltage Range: 2.0V to 24V
- 2% Output Voltage Accuracy
- Passes Automotive AEC-Q100 Reliability Testing
- Integrated N-Channel Buck Switch: 600 mΩ
- Minimum 500 mA Output Current Over All Input Voltage Ranges (see [Figure 2-9](#) for Maximum Output Current vs. V_{IN})
 - Up to 1.2A output current at 3.3V and 5V V_{OUT} , $V_{IN} > 12V$, SOT-23 package at +25°C ambient temperature
 - Up to 0.8A output current at 12V V_{OUT} , $V_{IN} > 18V$, SOT-23 package at +25°C ambient temperature
- 500 kHz Fixed Frequency
- Adjustable Output Voltage
- Low Device Shutdown Current
- Peak Current Mode Control
- Internal Soft Start
- Internal Compensation
- Internal Pull-up on the Enable pin
- Stable with Ceramic Capacitors
- Cycle-by-Cycle Peak Current Limit
- Undervoltage Lockout (UVLO): 4.1V to Start; 3.6V to Stop
- Overtemperature Protection
- Available Packages: 6-Lead SOT-23, 8-Lead 2 mm x 3 mm TDFN

Applications

- PIC® Microcontroller and dsPIC® Digital Signal Controller Bias Supply
- 48V, 24V and 12V Industrial Input DC-DC Conversion
- Set-Top Boxes
- DSL Cable Modems
- Automotive
- AC/DC Adapters
- SLA Battery-Powered Devices
- AC-DC Digital Control Power Source
- Power Meters
- Consumer
- Medical and Health Care
- Distributed Power Supplies

General Description

The MCP16331 device is a highly integrated, high-efficiency, fixed-frequency, step-down DC-DC converter in a popular 6-pin SOT-23 or 8-pin 2 mm x 3 mm TDFN package, that operates from input voltage sources up to 50V. Integrated features include a high-side switch, fixed frequency Peak Current-Mode control, internal compensation, peak current limit and overtemperature protection. Only a few external components are necessary to develop a complete step-down DC-DC converter power supply.

High converter efficiency is achieved by integrating the current-limited, low-resistance, high-speed N-Channel MOSFET and its associated driving circuitry. High switching frequency minimizes the size of external filtering components, resulting in a small solution size.

The MCP16331 can supply 500 mA of continuous current while regulating the output voltage from 2.0V to 24V. An integrated, high-performance Peak Current-Mode architecture keeps the output voltage tightly regulated, even during input voltage steps and output current transient conditions that are common in power systems.

The EN input is used to turn the device on and off. While off, only a few μA of current are consumed from the input for power shedding and load distribution applications. This pin is internally pulled up, so the device will start, even if the EN pin is left floating.

Output voltage is set with an external resistor divider. The MCP16331 is offered in a space-saving 6-lead SOT-23 and 8-lead 2 mm x 3 mm TDFN surface mount package.

Package Type

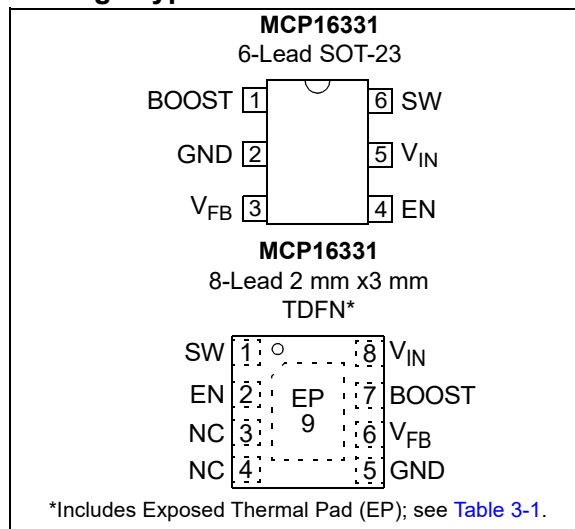

MCP16331

Typical Applications

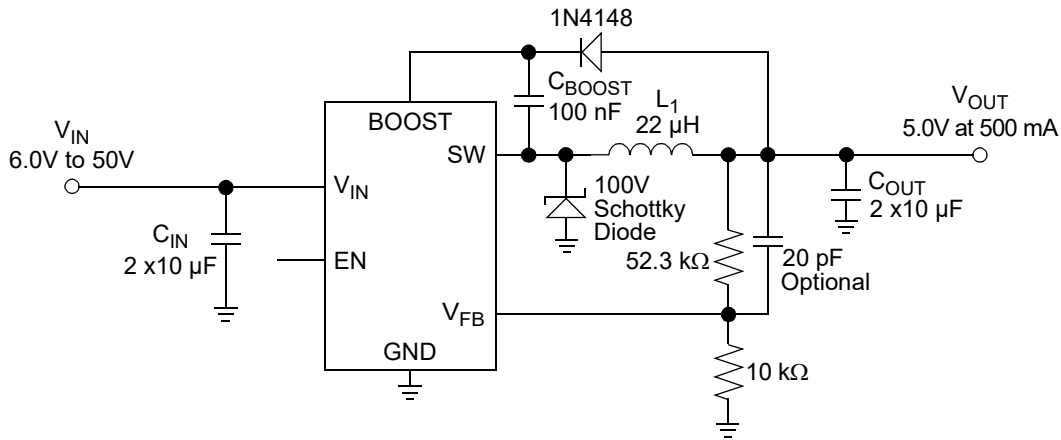
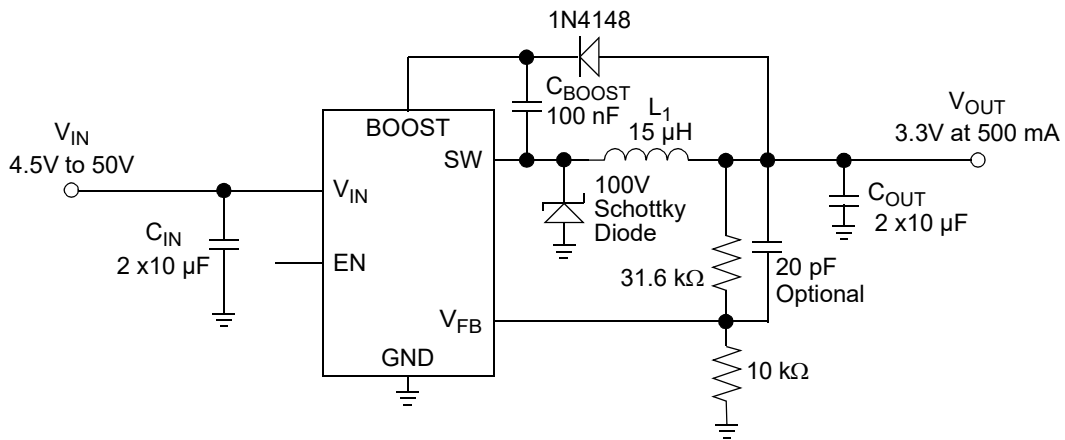

Note: EN has an internal pull-up, so the device will start even if the EN pin is left floating.

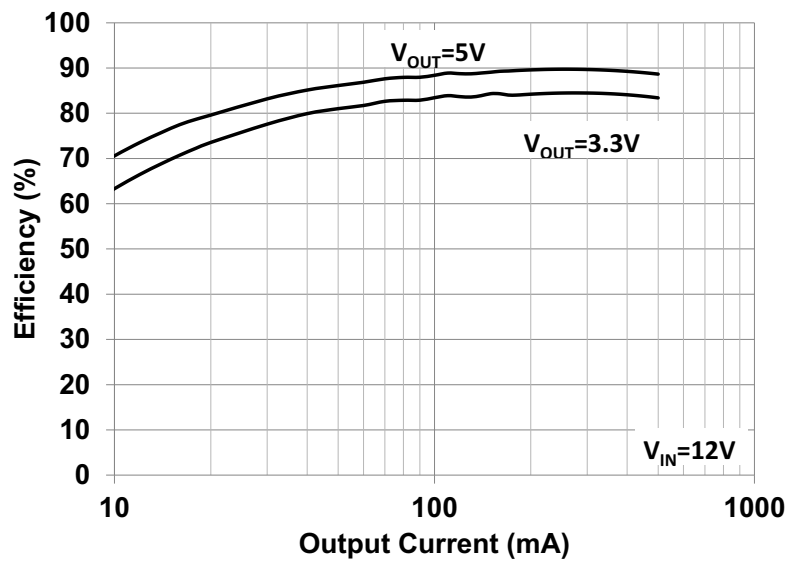

1.0 ELECTRICAL CHARACTERISTICS

Absolute Maximum Ratings†

$V_{IN, SW}$	-0.5V to 54V
BOOST – GND.....	-0.5V to 60V
BOOST – SW Voltage.....	-0.5V to 6.0V
V_{FB} Voltage	-0.5V to 6.0V
EN Voltage	-0.5V to ($V_{IN} + 0.3V$)
Output Short-Circuit Current	Continuous
Power Dissipation	Internally Limited
Storage Temperature	-65°C to +150°C
Ambient Temperature with Power Applied	-40°C to +125°C
Operating Junction Temperature.....	-40°C to +160°C
ESD Protection on All Pins:	
HBM.....	4 kV
MM	300V

† **Notice:** Stresses above those listed under “Maximum Ratings” may cause permanent damage to the device. This is a stress rating only and functional operation of the device at those or any other conditions above those indicated in the operational sections of this specification is not intended. Exposure to maximum rating conditions for extended periods may affect device reliability.

DC CHARACTERISTICS

Electrical Characteristics: Unless otherwise indicated, $T_A = +25^\circ\text{C}$, $V_{IN} = V_{EN} = 12V$, $V_{BOOST} - V_{SW} = 3.3V$, $V_{OUT} = 3.3V$, $I_{OUT} = 100\text{ mA}$, $L = 15\ \mu\text{H}$, $C_{OUT} = C_{IN} = 2 \times 10\ \mu\text{F}$ X7R Ceramic Capacitors.
Boldface specifications apply over the T_A range of -40°C to $+125^\circ\text{C}$.

Parameters	Sym.	Min.	Typ.	Max.	Units	Conditions
Input Voltage	V_{IN}	4.4	—	50	V	Note 1
Feedback Voltage	V_{FB}	0.784	0.800	0.816	V	
Output Voltage Adjust Range	V_{OUT}	2.0	—	24	V	Note 1 , Note 3
Feedback Voltage Line Regulation	$ (\Delta V_{FB}/V_{FB})/\Delta V_{IN} $	—	0.002	0.1	%/V	$V_{IN} = 5V$ to $50V$
Feedback Voltage Load Regulation	$ \Delta V_{FB}/V_{FB} $	—	0.13	0.35	%	$I_{OUT} = 50\text{ mA}$ to 500 mA
Feedback Input Bias Current	I_{FB}	—	+/- 3	—	nA	
Undervoltage Lockout Start	$UVLO_{STRT}$	—	4.1	4.4	V	V_{IN} rising
Undervoltage Lockout Stop	$UVLO_{STOP}$	3	3.6	—	V	V_{IN} falling
Undervoltage Lockout Hysteresis	$UVLO_{HYS}$	—	0.5	—	V	
Switching Frequency	f_{SW}	425	500	550	kHz	
Maximum Duty Cycle	DC_{MAX}	90	93	—	%	$V_{IN} = 5V$; $V_{FB} = 0.7V$; $I_{OUT} = 100\text{ mA}$
Minimum Duty Cycle	DC_{MIN}	—	1	—	%	Note 4
NMOS Switch-On Resistance	$R_{DS(ON)}$	—	0.6	—	Ω	$V_{BOOST} - V_{SW} = 5V$, Note 3
NMOS Switch Current Limit	$I_{N(MAX)}$	—	1.3	—	A	$V_{BOOST} - V_{SW} = 5V$, Note 3
Quiescent Current	I_Q	—	1	1.7	mA	$V_{IN} = 12V$; Note 2
Quiescent Current – Shutdown	I_Q	—	6	10	μA	$V_{OUT} = EN = 0V$
Output Current	I_{OUT}	500	—	—	mA	Note 1 ; see Figure 2-9

Note 1: The input voltage should be > output voltage + headroom voltage; higher load currents increase the input voltage necessary for regulation. See characterization graphs for typical input to output operating voltage range.

2: V_{BOOST} supply is derived from V_{OUT} .

3: Determined by characterization, not production tested.

4: This is ensured by design.

MCP16331

DC CHARACTERISTICS (CONTINUED)

Electrical Characteristics: Unless otherwise indicated, $T_A = +25^\circ\text{C}$, $V_{IN} = V_{EN} = 12\text{V}$, $V_{BOOST} - V_{SW} = 3.3\text{V}$, $V_{OUT} = 3.3\text{V}$, $I_{OUT} = 100\text{ mA}$, $L = 15\ \mu\text{H}$, $C_{OUT} = C_{IN} = 2 \times 10\ \mu\text{F X7R Ceramic Capacitors}$.
Boldface specifications apply over the T_A range of -40°C to $+125^\circ\text{C}$.

Parameters	Sym.	Min.	Typ.	Max.	Units	Conditions
EN Input Logic High	V_{IH}	1.9	—	—	V	
EN Input Logic Low	V_{IL}	—	—	0.4	V	
EN Input Leakage Current	I_{ENLK}	—	0.007	0.5	μA	$V_{IN} = EN = 5\text{V}$
Soft Start Time	t_{SS}	—	600	—	μs	EN Low-to-high, 90% of V_{OUT}
Thermal Shutdown Die Temperature	T_{SD}	—	160	—	$^\circ\text{C}$	Note 3
Die Temperature Hysteresis	T_{SDHYS}	—	30	—	$^\circ\text{C}$	Note 3

Note 1: The input voltage should be $>$ output voltage + headroom voltage; higher load currents increase the input voltage necessary for regulation. See characterization graphs for typical input to output operating voltage range.

2: V_{BOOST} supply is derived from V_{OUT} .

3: Determined by characterization, not production tested.

4: This is ensured by design.

TEMPERATURE SPECIFICATIONS

Electrical Specifications						
Parameters	Sym.	Min.	Typ.	Max.	Units	Conditions
Temperature Ranges						
Operating Junction Temperature Range	T_J	-40	—	+125	$^\circ\text{C}$	Steady State
Storage Temperature Range	T_A	-65	—	+150	$^\circ\text{C}$	
Maximum Junction Temperature	T_J	—	—	+160	$^\circ\text{C}$	Transient
Package Thermal Resistances						
Thermal Resistance, 6L-SOT-23	θ_{JA}	—	190.5	—	$^\circ\text{C/W}$	EIA/JESD51-3 Standard
Thermal Resistance, 8L-2 mm x 3 mm TDFN	θ_{JA}	—	52.5	—	$^\circ\text{C/W}$	EIA/JESD51-3 Standard

2.0 TYPICAL PERFORMANCE CURVES

Note: The graphs and tables provided following this note are a statistical summary based on a limited number of samples and are provided for informational purposes only. The performance characteristics listed herein are not tested or guaranteed. In some graphs or tables, the data presented may be outside the specified operating range (e.g., outside specified power supply range) and therefore outside the warranted range.

Note: Unless otherwise indicated, $V_{IN} = EN = 12V$, $C_{OUT} = C_{IN} = 2 \times 10 \mu F$, $L = 15 \mu H$, $V_{OUT} = 3.3V$, $I_{LOAD} = 100 \text{ mA}$, $T_A = +25^\circ C$, 6-Lead SOT-23 package.

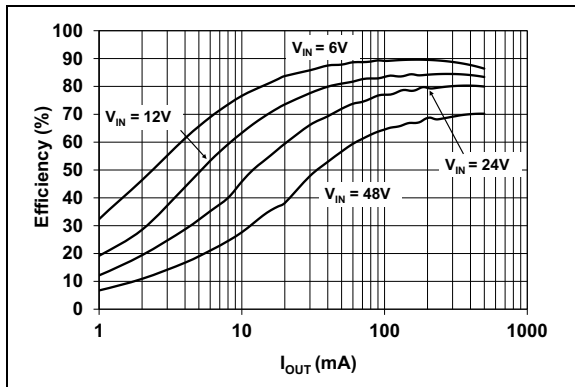

FIGURE 2-1: 3.3V V_{OUT} Efficiency vs. I_{OUT} .

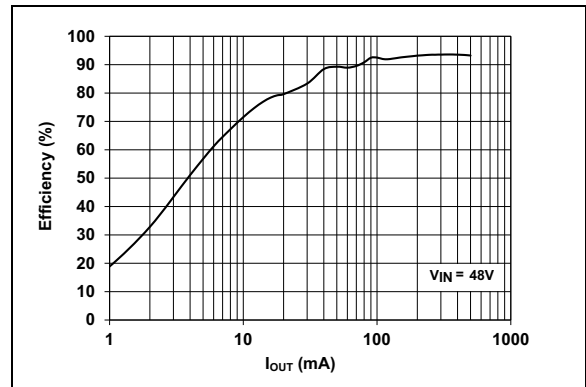

FIGURE 2-4: 24V V_{OUT} Efficiency vs. I_{OUT} .

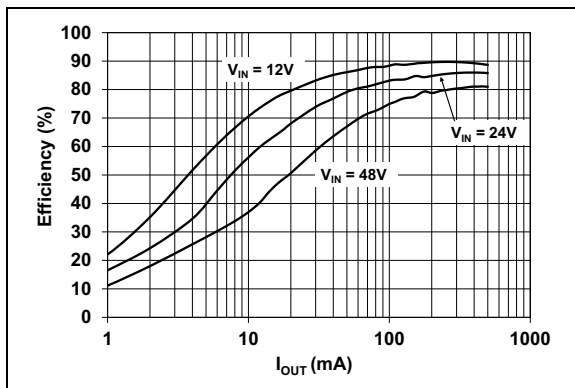

FIGURE 2-2: 5V V_{OUT} Efficiency vs. I_{OUT} .

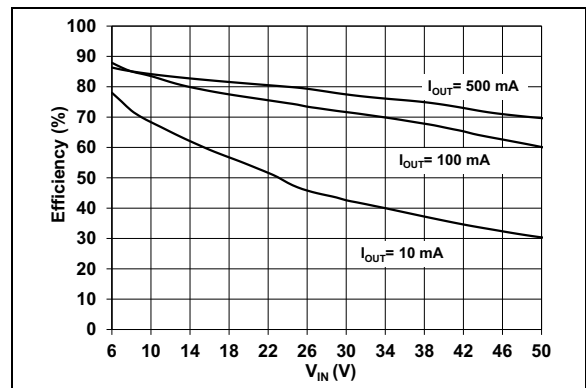

FIGURE 2-5: 3.3V V_{OUT} Efficiency vs. V_{IN} .

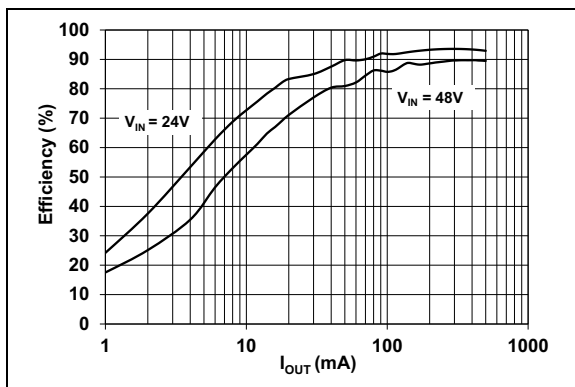

FIGURE 2-3: 12V V_{OUT} Efficiency vs. I_{OUT} .

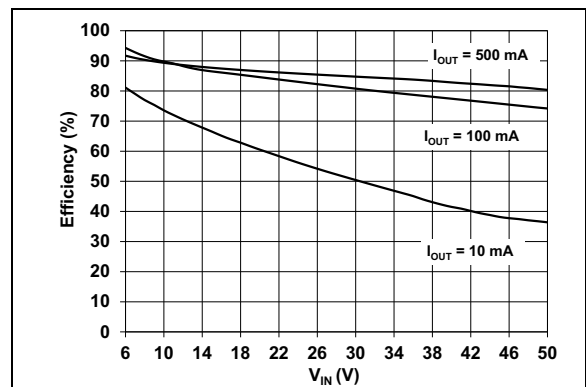

FIGURE 2-6: 5V V_{OUT} Efficiency vs. V_{IN} .

MCP16331

Note: Unless otherwise indicated, $V_{IN} = EN = 12V$, $C_{OUT} = C_{IN} = 2 \times 10 \mu F$, $L = 15 \mu H$, $V_{OUT} = 3.3V$, $I_{LOAD} = 100 \text{ mA}$, $T_A = +25^\circ C$, 6-Lead SOT-23 package.

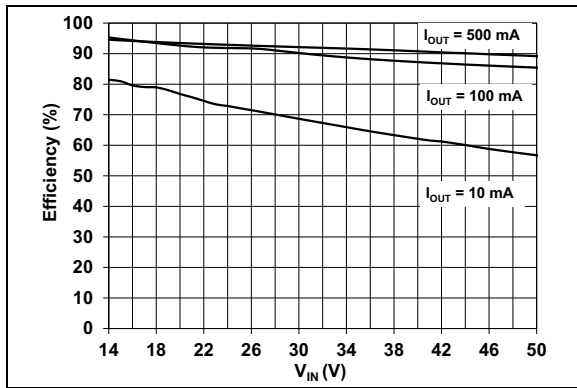

FIGURE 2-7: 12V V_{OUT} Efficiency vs. V_{IN} .

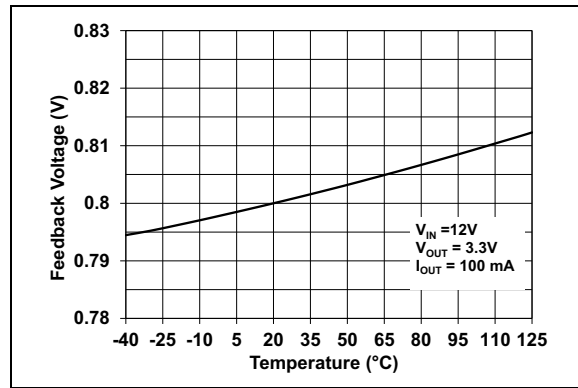

FIGURE 2-10: V_{FB} vs. Temperature.

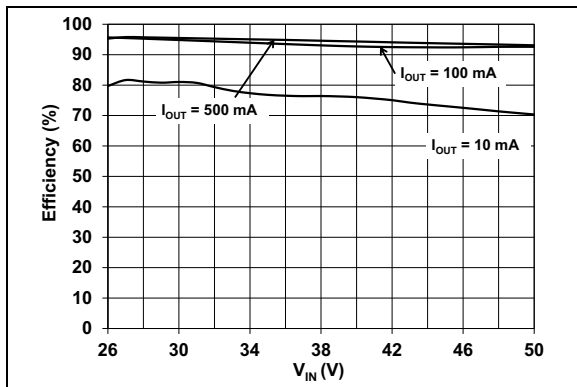

FIGURE 2-8: 24V V_{OUT} Efficiency vs. V_{IN} .

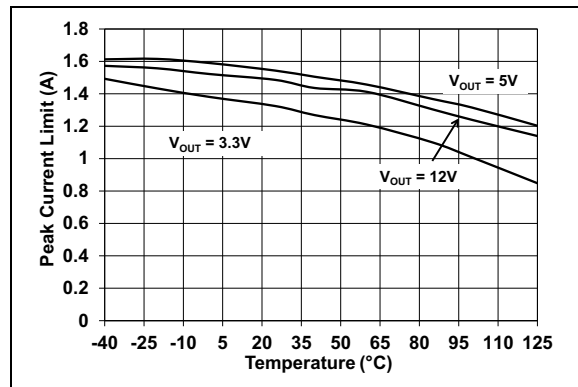

FIGURE 2-11: Peak Current Limit vs. Temperature.

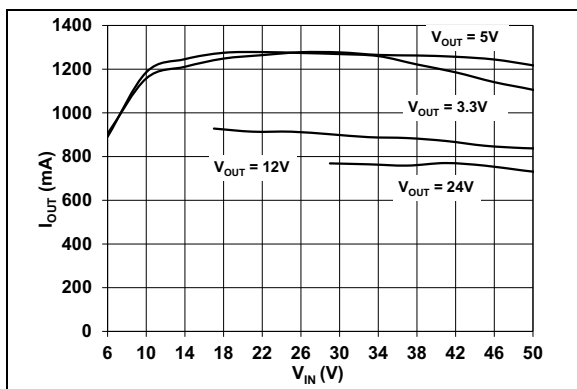

FIGURE 2-9: Max I_{OUT} vs. V_{IN} .

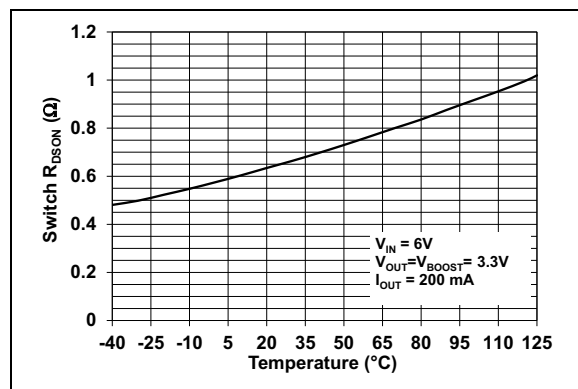

FIGURE 2-12: Switch $R_{DS(on)}$ vs. Temperature.

Note: Unless otherwise indicated, $V_{IN} = EN = 12V$, $C_{OUT} = C_{IN} = 2 \times 10 \mu F$, $L = 15 \mu H$, $V_{OUT} = 3.3V$, $I_{LOAD} = 100 \text{ mA}$, $T_A = +25^\circ C$, 6-Lead SOT-23 package.

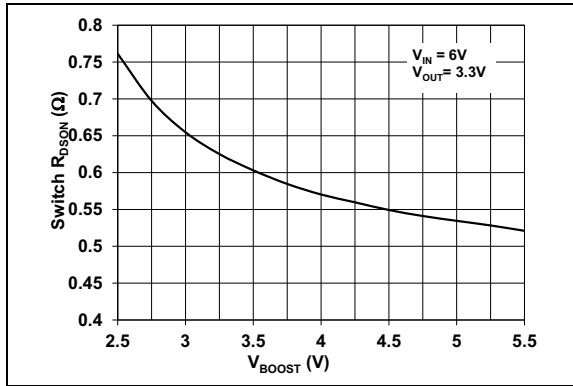

FIGURE 2-13: Switch R_{DSON} vs. V_{BOOST} .

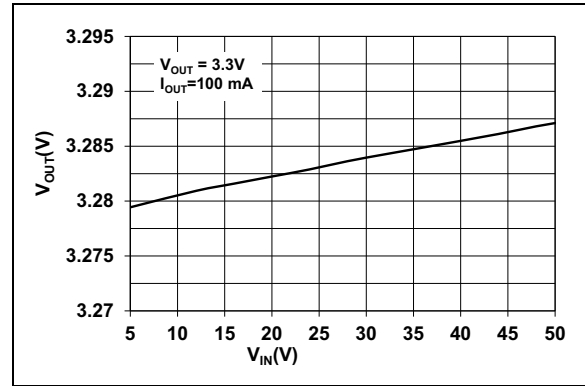

FIGURE 2-16: V_{OUT} vs. V_{IN} .

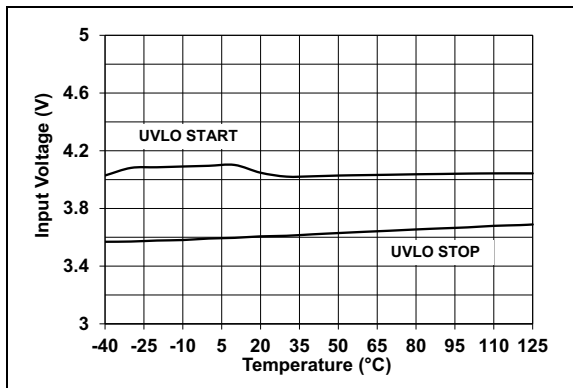

FIGURE 2-14: Undervoltage Lockout vs. Temperature.

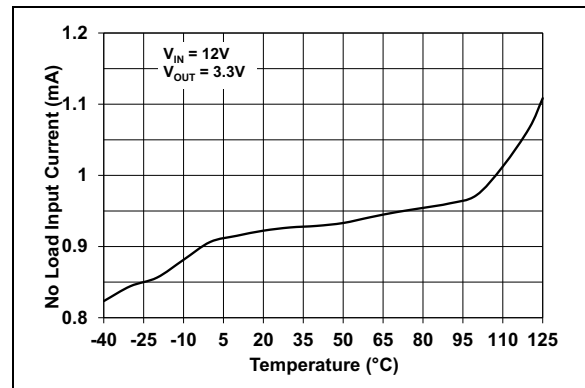

FIGURE 2-17: Input Quiescent Current vs. Temperature.

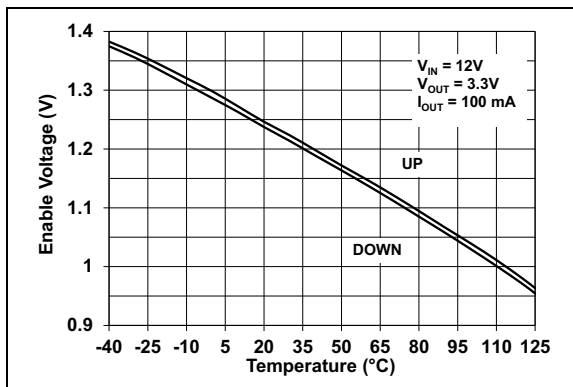

FIGURE 2-15: EN Threshold Voltage vs. Temperature.

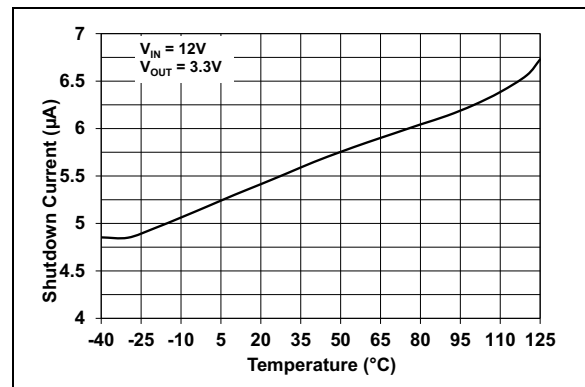

FIGURE 2-18: Shutdown Current vs. Temperature.

MCP16331

Note: Unless otherwise indicated, $V_{IN} = EN = 12V$, $C_{OUT} = C_{IN} = 2 \times 10 \mu F$, $L = 15 \mu H$, $V_{OUT} = 3.3V$, $I_{LOAD} = 100 mA$, $T_A = +25^\circ C$, 6-Lead SOT-23 package.

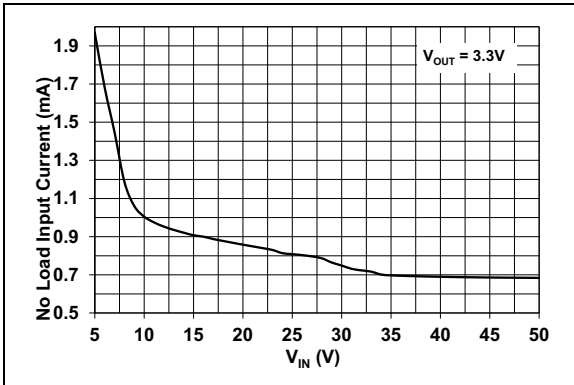

FIGURE 2-19: Input Quiescent Current vs. V_{IN} .

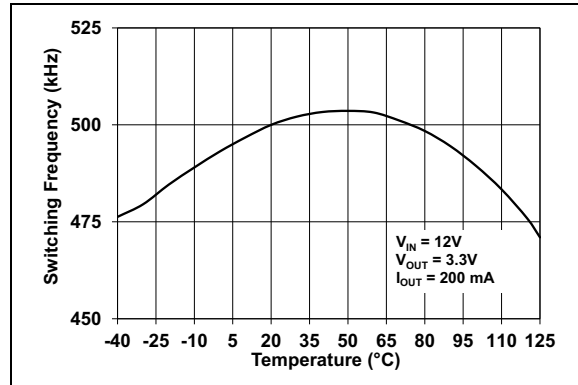

FIGURE 2-22: Switching Frequency vs. Temperature.

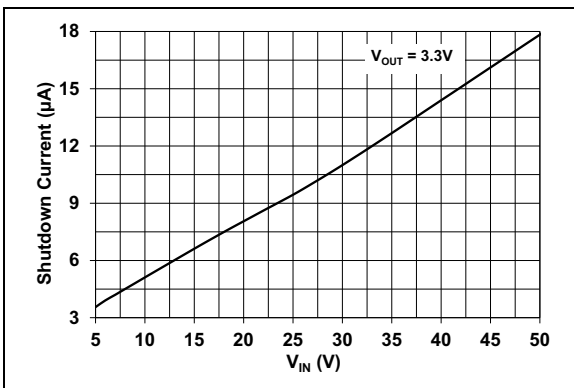

FIGURE 2-20: Shutdown Current vs. V_{IN} .

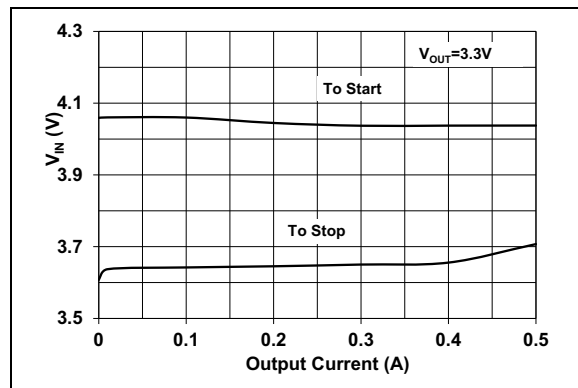

FIGURE 2-23: Minimum Input Voltage vs. Output Current.

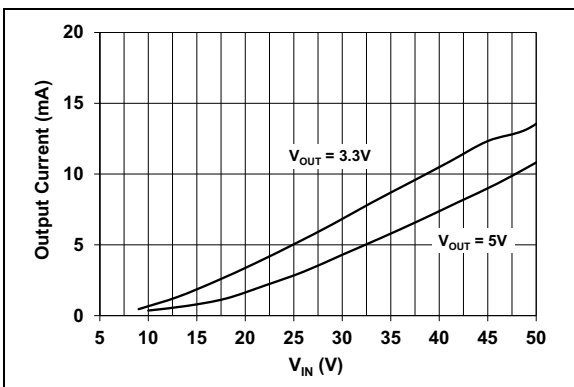

FIGURE 2-21: PWM/Skipping I_{OUT} Threshold vs. V_{IN} .

Note: Unless otherwise indicated, $V_{IN} = EN = 12V$, $C_{OUT} = C_{IN} = 2 \times 10 \mu F$, $L = 15 \mu H$, $V_{OUT} = 3.3V$, $I_{LOAD} = 100 \text{ mA}$, $T_A = +25^\circ C$, 6-Lead SOT-23 package.

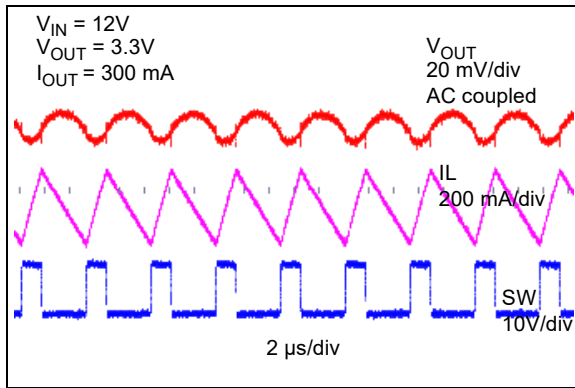

FIGURE 2-24: Heavy Load Switching Waveforms.

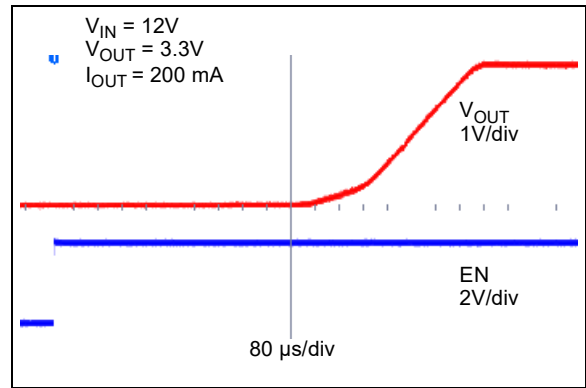

FIGURE 2-27: Start-up from EN.

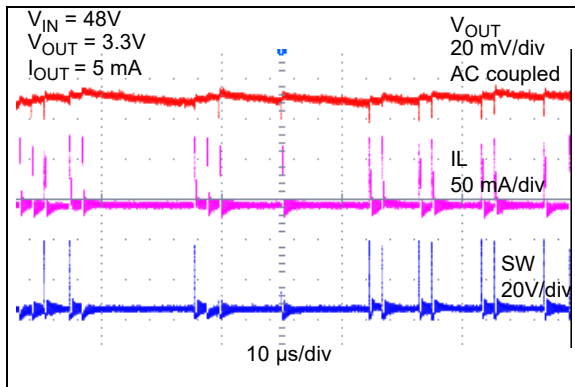

FIGURE 2-25: Light Load Switching Waveforms.

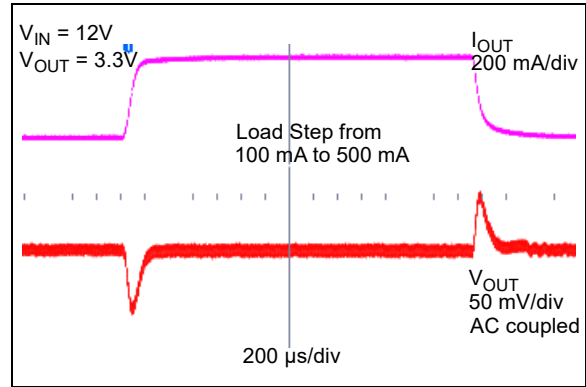

FIGURE 2-28: Load Transient Response.

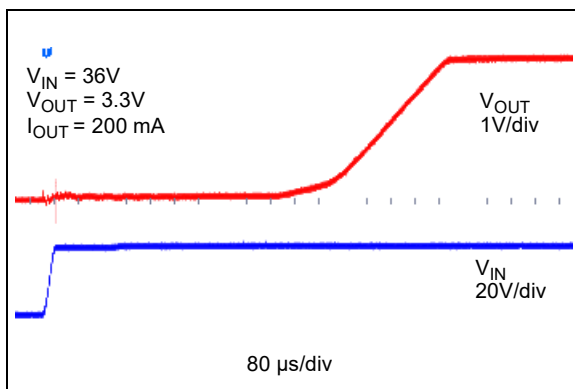

FIGURE 2-26: Start-up from V_{IN} .

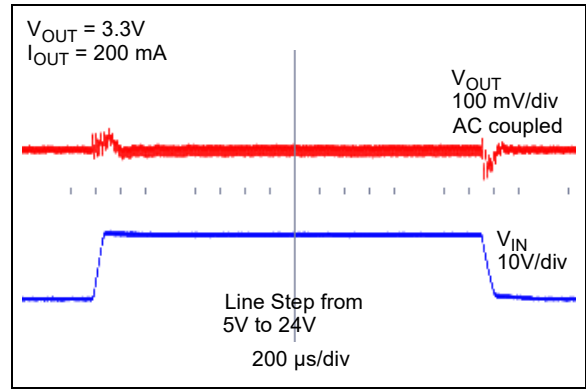

FIGURE 2-29: Line Transient Response.

MCP16331

NOTES:

3.0 PIN DESCRIPTIONS

The descriptions of the pins are listed in [Table 3-1](#).

TABLE 3-1: PIN FUNCTION TABLE

MCP16331		Symbol	Description
TDFN	SOT-23		
1	6	SW	Output switch node. Connects to the inductor, the freewheeling diode and the bootstrap capacitor.
2	4	EN	Enable pin. There is an internal pull-up on the V_{IN} . To turn the device off, connect EN to GND.
3	—	NC	Not connected.
4	—	NC	Not connected.
5	2	GND	Ground pin.
6	3	V_{FB}	Output voltage feedback pin. Connect V_{FB} to an external resistor divider to set the output voltage.
7	1	BOOST	Boost voltage that drives the internal NMOS control switch. A bootstrap capacitor is connected between the BOOST and SW pins.
8	5	V_{IN}	Input supply voltage pin for power and internal biasing.
9	—	EP	Exposed Thermal Pad

3.1 Switch Node Pin (SW)

The switch node pin is internally connected to the N-Channel MOSFET switch, and externally to the SW node, consisting of the inductor and Schottky diode. The external Schottky diode should be connected close to the SW node and GND.

3.2 Enable Pin (EN)

The EN pin is a logic-level input used to enable or disable the device switching and lower the quiescent current while disabled. By default, the MCP16331 is enabled through an internal pull-up. To turn off the device, the EN pin must be pulled low.

3.3 Ground Pin (GND)

The ground or return pin is used for circuit ground connection. The length of the trace from the input capacitor return, output capacitor return and GND pin should be made as short as possible, to minimize the noise on the GND pin.

3.4 Feedback Voltage Pin (V_{FB})

The V_{FB} pin is used to provide output voltage regulation by using a resistor divider. The V_{FB} voltage will be 0.8V typical, with the output voltage in regulation.

3.5 Boost Pin (BOOST)

The supply for the floating high-side driver, used to turn the integrated N-Channel MOSFET on and off, is connected to the BOOST pin.

3.6 Power Supply Input Voltage Pin (V_{IN})

Connect the input voltage source to V_{IN} . The input source should be decoupled to GND with a 4.7 μ F–20 μ F capacitor, depending on the impedance of the source and output current. The input capacitor provides AC current for the power switch and a stable voltage source for the internal device power. This capacitor should be connected as close as possible to the V_{IN} and GND pins.

3.7 Exposed Thermal Pad Pin (EP)

There is an internal electrical connection between the EP and GND pin for the TDFN package.

MCP16331

NOTES:

4.0 DETAILED DESCRIPTION

4.1 Device Overview

The MCP16331 device is a high input voltage step-down regulator, capable of supplying 500 mA to a stable output voltage, from 2.0V to 24V. Internally, the trimmed 500 kHz oscillator provides a fixed frequency, while the Peak Current-Mode control architecture varies the duty cycle for output voltage regulation. An internal floating driver is used to turn the high-side, integrated N-Channel MOSFET on and off. The power for this driver is derived from an external boost capacitor (C_{BOOST}) whose energy is supplied from a fixed voltage, ranging between 3.0V and 5.5V, typically the input or output voltage of the converter. For applications with an output voltage outside of this range, 12V for example, the boost capacitor bias can be derived from the output using a simple Zener diode.

4.1.1 INTERNAL REFERENCE VOLTAGE (V_{REF})

An integrated precise 0.8V reference, combined with an external resistor divider, sets the desired converter output voltage. The resistor divider range can vary without affecting the control system gain. High-value resistors consume less current, but are more susceptible to noise.

4.1.2 INTERNAL COMPENSATION

All control system components necessary for stable operation over the entire device operating range are integrated, including the error amplifier and the inductor current slope compensation. To add the proper amount of slope compensation, the inductor value changes along with the output voltage (see [Table 5-1](#)).

4.1.3 EXTERNAL COMPONENTS

External components consist of:

- Input capacitor
- Output filter (inductor and capacitor)
- Freewheeling diode
- Boost capacitor
- Boost blocking diode
- Resistor divider

The selection of the inductor, output capacitor, input capacitor and freewheeling diode is dependent upon the output voltage, input voltage, and the maximum output current.

4.1.4 ENABLE INPUT

The enable input is used to disable the device while connected to GND. If disabled, the MCP16331 device consumes a minimal amount of current from the input.

4.1.5 SOFT START

The internal reference voltage rate of rise is controlled during start-up, minimizing the output voltage overshoot and the inrush current.

4.1.6 UNDERVOLTAGE LOCKOUT

An integrated Undervoltage Lockout (UVLO) prevents the converter from starting until the input voltage is high enough for normal operation. The converter will typically start at 4.1V and operate down to 3.6V. Hysteresis is added to prevent starting and stopping during start-up, as a result of loading the input voltage source.

4.1.7 OVERTEMPERATURE PROTECTION

Overtemperature protection limits the silicon die temperature to +160°C, by turning the converter off; the normal switching resumes at +130°C.

MCP16331

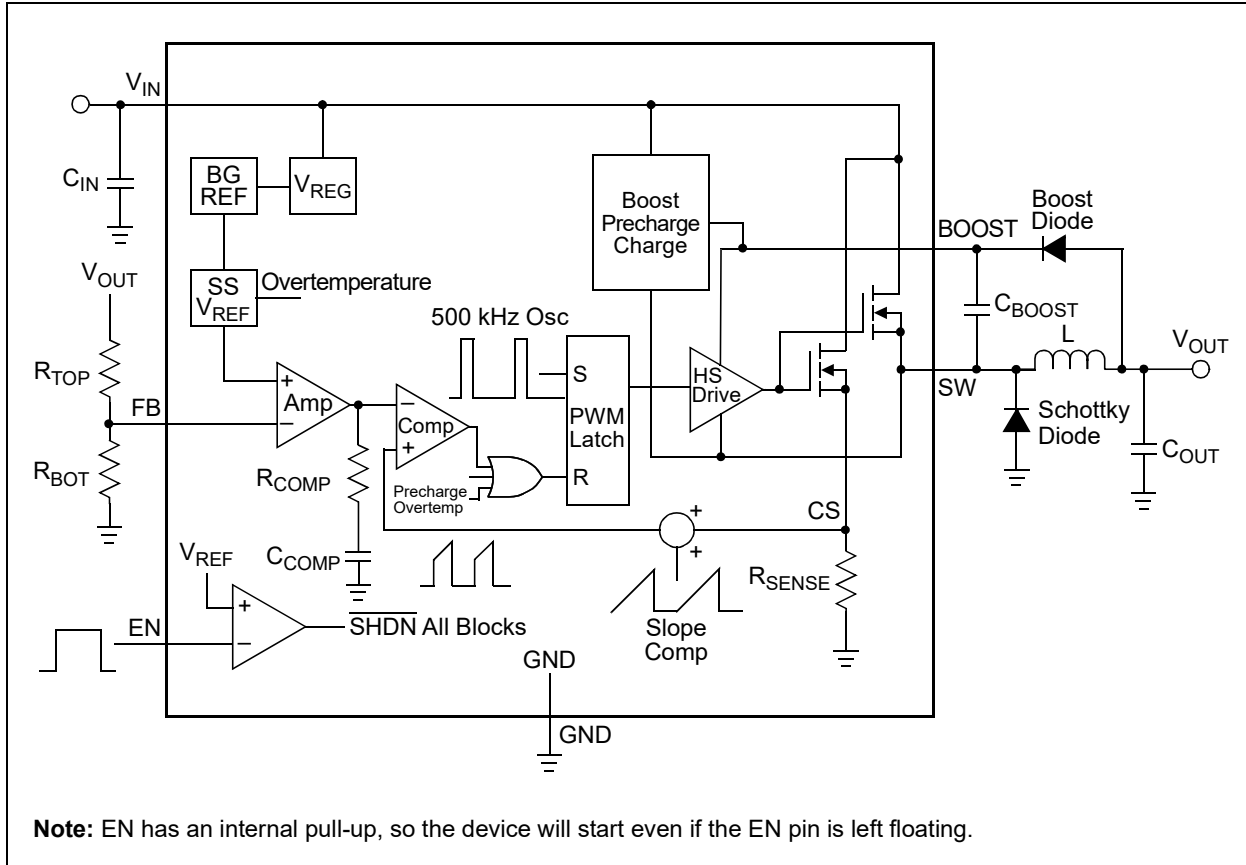

FIGURE 4-1: MCP16331 Block Diagram.

4.2 Functional Description

4.2.1 STEP-DOWN OR BUCK CONVERTER

The MCP16331 device is a non-synchronous, step-down or buck converter capable of stepping input voltages ranging from 4.4V to 50V down to 2.0V to 24V for $V_{IN} > V_{OUT}$.

The integrated high-side switch is used to chop or modulate the input voltage using a controlled duty cycle for output voltage regulation. High efficiency is achieved by using a low-resistance switch, low forward drop diode (Schottky diode), low Equivalent Series Resistance (ESR) capacitors and low Direct Current Resistance (DCR) inductor. When the switch is turned on, a DC voltage is applied across the inductor ($V_{IN} - V_{OUT}$), resulting in a positive linear ramp of inductor current. When the switch turns off, the applied inductor voltage is equal to $-V_{OUT}$, resulting in a negative linear ramp of inductor current (ignoring the forward drop of the Schottky diode).

For steady-state, continuous inductor current operation, the positive inductor current ramp must equal the negative current ramp in magnitude. While operating in steady state, the switch duty cycle must be equal to the relationship of V_{OUT}/V_{IN} for constant output voltage regulation, under the condition that the inductor current is continuous or never reaches zero. For discontinuous inductor current operation, the steady-state duty cycle will be less than V_{OUT}/V_{IN} to maintain voltage regulation. The average of the chopped input voltage or SW node voltage is equal to the output voltage, while the average of the inductor current is equal to the output current.

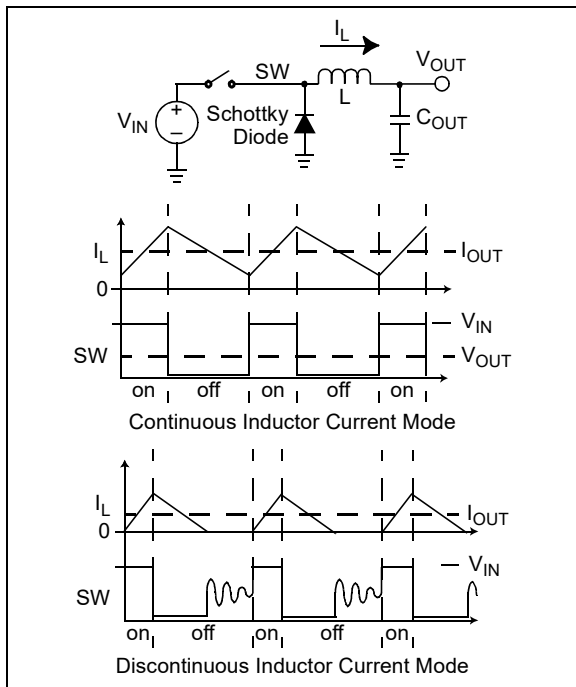

FIGURE 4-2: Step-Down Converter.

4.2.2 PEAK CURRENT MODE CONTROL

The MCP16331 integrates a Peak Current-Mode control architecture, resulting in superior AC regulation while minimizing the number of voltage loop compensation components and their size, for integration. Peak Current-Mode control takes a small portion of the inductor current, replicates it and compares this replicated current sense signal with the output of the integrated error voltage. In practice, the inductor current and the internal switch current are equal during the switch-on time. By adding this peak current sense to the system control, the step-down power train system is reduced from a 2nd order to a 1st order. This reduces the system complexity and increases its dynamic performance.

For Pulse-Width Modulation (PWM) duty cycles that exceeds 50%, the control system can become bimodal, where a wide pulse, followed by a short pulse, repeats instead of the desired fixed pulse width. To prevent this mode of operation, an internal compensating ramp is summed into the current shown in [Figure 4-2](#).

4.2.3 PULSE-WIDTH MODULATION (PWM)

The internal oscillator periodically starts the switching cycle, which for MCP16331, occurs every 2 μ s (or with a frequency of 500 kHz). With the integrated switch turned on, the inductor current ramps up until the sum of the current sense and slope compensation ramp exceeds the integrated error amplifier output. The error amplifier output slews up or down to increase or decrease the inductor peak current feeding into the output LC filter. If the regulated output voltage is lower than its target, the

error amplifier output rises. This results in an increase of the inductor current, to correct for error in the output voltage. The fixed frequency duty cycle is terminated when the sensed inductor peak current, summed with the internal slope compensation, exceeds the output voltage of the error amplifier. The PWM latch is set by turning off the internal switch and preventing it from turning on until the beginning of the next cycle. An overtemperature signal or boost capacitor undervoltage can also reset the PWM latch, to asynchronously terminate the cycle.

When working close to the boundary conduction threshold, a jitter on the SW node may occur, reflecting it into the output voltage. Although the low-frequency output component is very small, it may be desirable to completely eliminate this component. To achieve this, different methods can be applied to reduce or completely eliminate this component. In addition to a very good layout, a capacitor connected in parallel with the top feedback resistor, or an RC snubber between the SW node and GND, can be added.

Typical values for the snubber are 680 pF and 430 Ω , while the capacitor connected in parallel with the top feedback resistor can have values from 10 pF to 47 pF. Utilizing such a snubber eliminates the ringing on the SW node, but decreases the overall efficiency of the converter.

4.2.4 HIGH-SIDE DRIVE

The MCP16331 features an integrated high-side N-Channel MOSFET for high-efficiency step-down power conversion; an N-Channel MOSFET is preferred for its low resistance and size (instead of a P-Channel MOSFET). The N-Channel MOSFET gate must be driven above its source to fully turn on the transistor, therefore, a gate-drive voltage above the input is necessary to turn on the high-side N-Channel switch. The high-side drive voltage should be between 3.0V and 5.5V. The N-Channel MOSFET source is connected to the inductor and Schottky diode, or switch node.

When the switch is off, the boost capacitor voltage is replenished, typically from the output voltage, for 3V to 5V output applications. A boost-blocking diode is used to prevent current flow from the boost capacitor back into the output during the internal switch-on time.

Prior to start-up, the boost capacitor has no stored charge to drive the switch, therefore an internal regulator is used to “precharge” the boost capacitor. Once precharged, the switch is turned on and the inductor current starts to flow. When the switch turns off, the inductor current freewheels through the Schottky diode, providing a path to recharge the boost capacitor. Worst-case conditions for recharge occur when the switch turns on for a very short duty cycle at light load, limiting the inductor current ramp. In this case, there is a

MCP16331

small amount of time for the boost capacitor to recharge. For high input voltages, there is enough precharge current to replenish the boost capacitor charge.

For input voltages above 5.5V typical, the MCP16331 device will regulate the output voltage with no load. After starting, the MCP16331 will regulate the output voltage until the input voltage decreases below 4V. See [Figure 2-23](#) for device range of operation over input voltage, output voltage and load.

4.2.5 ALTERNATIVE BOOST BIAS

For 3.0V to 5.0V output voltage applications, the boost supply is typically the output voltage. For applications with the output voltage lower than 3V or higher than 5V, an alternative boost supply can be used.

Alternative boost supplies can be directly used from the input, input derived, output derived or an auxiliary system voltage.

For low-voltage output applications with unregulated input voltage, a shunt regulator derived from the input can be used to derive the boost supply. For applications with high output voltage or regulated high input voltage, a series regulator can be used to derive the boost supply. In case the boost is biased from an external source while in shutdown, the device will draw slightly higher current.

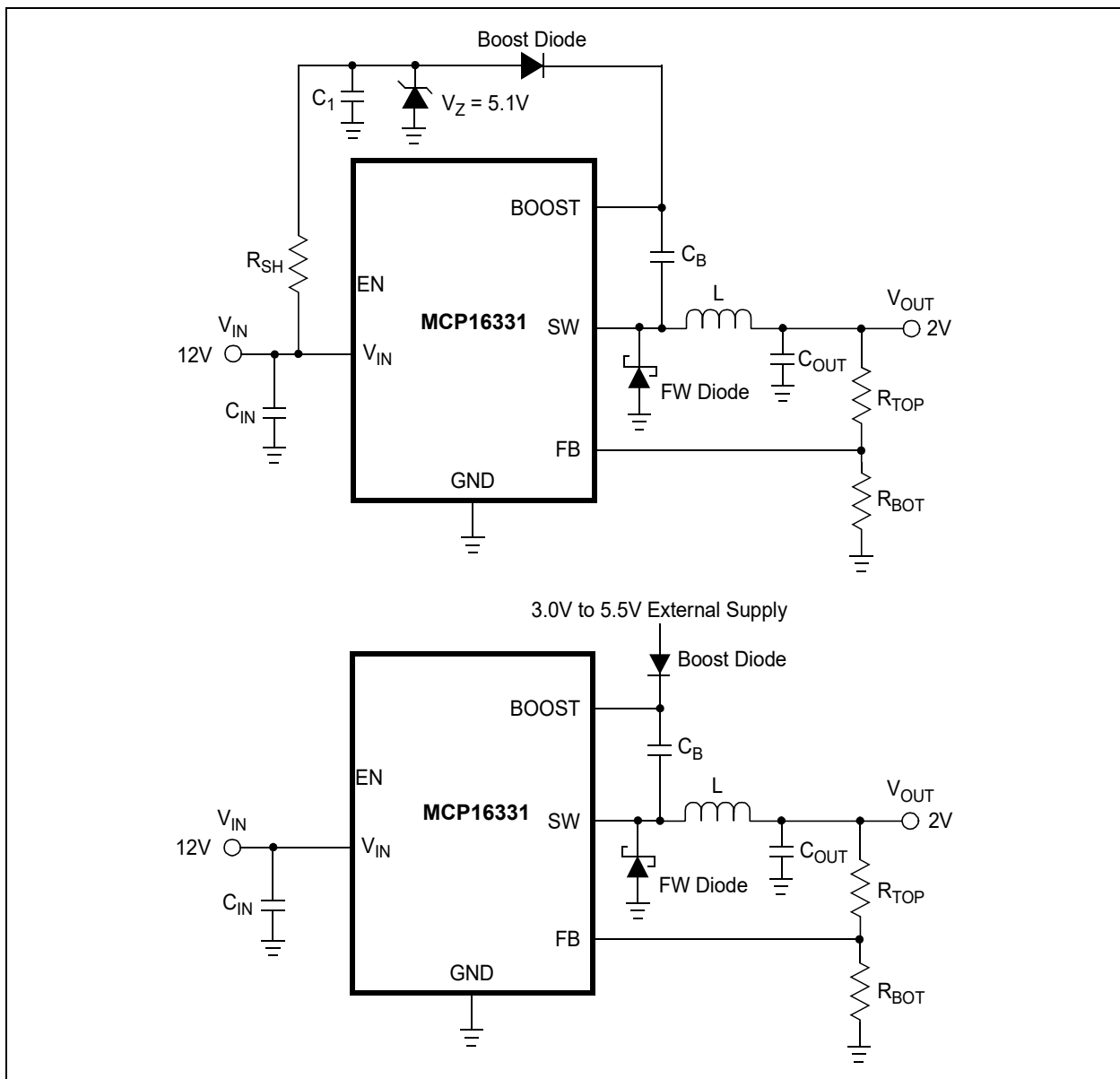

FIGURE 4-3: MCP16331 Shunt and External Boost Supply.

Shunt boost supply regulation is used for low output voltage converters operating from a wide ranging input source; a regulated 3.0V to 5.5V supply is needed to provide high-side drive bias. The shunt uses a Zener diode to clamp the voltage within the 3.0V to 5.5V range, using the R_{SH} resistor shown in Figure 4-3.

To calculate the R_{SH} resistor value, the boost drive current needs to be estimated first, using Equation 4-1.

I_{BOOST_TYP} for 3.3V Boost Supply = 0.6 mA

I_{BOOST_TYP} for 5.0V Boost Supply = 0.8 mA.

EQUATION 4-1: BOOST CURRENT

$$I_{BOOST} = I_{BOOST_TYP} \times 1.5 \text{ mA}$$

To calculate the R_{SH} resistor value, the maximum I_{BOOST} and I_Z current are used at the minimum input voltage (Equation 4-2).

EQUATION 4-2: SHUNT RESISTANCE

$$R_{SH} = \frac{V_{INMIN} - V_Z}{I_{Boost} + I_Z}$$

V_Z and I_Z can be found on the Zener diode manufacturer's data sheet; typically, $I_Z = 1 \text{ mA}$.

Series regulator applications use a Zener diode to drop the excess voltage; the series regulator bias source can be input or output voltage derived, as shown in Figure 4-4. For proper circuit operation, the boost supply must remain between 3.0V and 5.5V at all times.

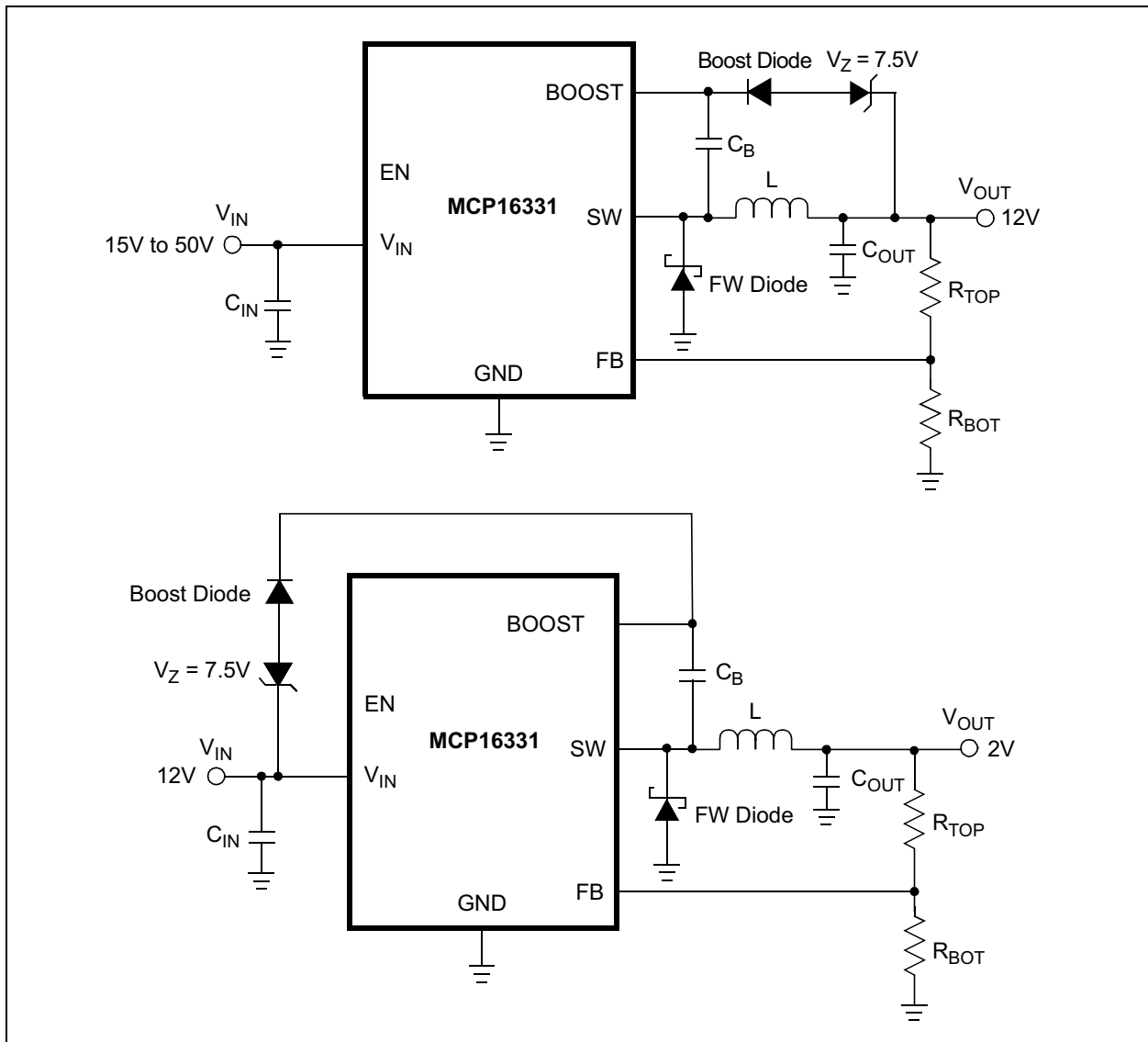

FIGURE 4-4: MCP16331 Series Regulator Boost Supply.

MCP16331

NOTES:

5.0 APPLICATION INFORMATION

5.1 Typical Applications

The MCP16331 step-down converter operates over a wide input voltage range, up to 50V maximum. Typical applications include generating a bias or V_{DD} voltage for the PIC[®] microcontroller product line, digital control system bias supply for AC-DC converters, 24V industrial input and similar applications.

5.2 Adjustable Output Voltage Calculations

To calculate the resistor divider values for the MCP16331, Equation 5-1 can be used. R_{TOP} is connected to V_{OUT} , R_{BOT} is connected to GND and both are connected to the V_{FB} input pin.

EQUATION 5-1:

$$R_{TOP} = R_{BOT} \times \left(\frac{V_{OUT}}{V_{FB}} - 1 \right)$$

EXAMPLE 5-1:

$$\begin{aligned} V_{OUT} &= 3.3V \\ V_{FB} &= 0.8V \\ R_{BOT} &= 10 \text{ k}\Omega \\ R_{TOP} &= 31.25 \text{ k}\Omega \text{ (standard value} = 31.6 \text{ k}\Omega) \\ V_{OUT} &= 3.328V \text{ (using standard value)} \end{aligned}$$

EXAMPLE 5-2:

$$\begin{aligned} V_{OUT} &= 5.0V \\ V_{FB} &= 0.8V \\ R_{BOT} &= 10 \text{ k}\Omega \\ R_{TOP} &= 52.5 \text{ k}\Omega \text{ (standard value} = 52.3 \text{ k}\Omega) \\ V_{OUT} &= 4.98V \text{ (using standard value)} \end{aligned}$$

The transconductance error amplifier gain is controlled by its internal impedance. The external resistor divider have no effect on system gain, so a wide range of values can be used. A 10 k Ω bottom resistor is recommended as a good trade-off for quiescent current and noise immunity.

5.3 General Design Equations

The step-down converter duty cycle can be estimated using Equation 5-2, while operating in Continuous Inductor Current-Mode. This equation also counts the forward drop of the freewheeling diode and internal N-Channel MOSFET switch voltage drop. As the load current increases, the switch voltage drop and diode voltage drop increase as well, requiring a larger PWM duty cycle to maintain the output voltage regulation. Switch voltage drop is estimated by multiplying the switch current times the switch resistance ($R_{DS(ON)}$).

EQUATION 5-2: CONTINUOUS INDUCTOR CURRENT DUTY CYCLE

$$D = \frac{(V_{OUT} + V_{Diode})}{(V_{IN} - (I_{SW} \times R_{DS(ON)})}$$

The MCP16331 device features an integrated slope compensation to prevent the bimodal operation of the PWM duty cycle. Internally, half of the inductor current downslope is summed with the internal current sense signal. For the proper amount of slope compensation, it is recommended to keep the inductor down-slope current constant, by varying the inductance with V_{OUT} , where $K = 0.22 \text{ V}/\mu\text{H}$.

EQUATION 5-3:

$$K = V_{OUT}/L$$

For $V_{OUT} = 3.3V$, an inductance of 15 μH is recommended.

TABLE 5-1: RECOMMENDED INDUCTOR VALUES

V_{OUT}	K	$L_{STANDARD}$
2.0V	0.20	10 μH
3.3V	0.22	15 μH
5.0V	0.23	22 μH
12V	0.21	56 μH
15V	0.22	68 μH
24V	0.24	100 μH

MCP16331

5.4 Input Capacitor Selection

The step-down converter input capacitor must filter the high input current ripple as a result of pulsing or chopping the input voltage. The MCP16331 input voltage pin is used to supply voltage for the power train and as a source for internal bias. A low Equivalent Series Resistance (ESR), preferably a ceramic capacitor, is recommended. The necessary capacitance is dependent upon the maximum load current and source impedance. Three capacitor parameters to keep in mind are the voltage rating, Equivalent Series Resistance and the temperature rating. For wide temperature range applications, a multilayer X7R dielectric is mandatory, while for applications with limited temperature range, a multilayer X5R dielectric is acceptable. Typically, input capacitance between 4.7 μF and 20 μF is sufficient for most applications.

The input capacitor voltage rating should be a minimum of V_{IN} plus margin. Table 5-2 contains the recommended range for the input capacitor value.

5.5 Output Capacitor Selection

The output capacitor helps in providing a stable output voltage during sudden load transients and reduces the output voltage ripple. As with the input capacitor, X5R and X7R ceramic capacitors are well suited for this application.

The amount and type of output capacitance, as well as the Equivalent Series Resistance will have a significant effect on the output ripple voltage and system stability. The range of the output capacitance is limited due to the integrated compensation of the MCP16331.

The output capacitor voltage rating should be minimum V_{OUT} plus margin. Table 5-2 contains the recommended range for the input and output capacitor value:

TABLE 5-2: CAPACITOR VALUE RANGE

Parameter	Min.	Max.
C_{IN}	4.7 μF	None
C_{OUT}	20 μF	—

5.6 Inductor Selection

The MCP16331 is designed to be used with small surface mount (SMT/SMD) inductors. Several specifications should be considered prior to selecting an inductor. To optimize system performance, the inductance value is determined based on the output voltage (Table 5-1), so the inductor current ripple is somewhat constant over the output voltage range. The inductor current ripple can be calculated using Equation 5-4.

EQUATION 5-4: INDUCTOR CURRENT RIPPLE

$$\Delta I_L = \frac{V_{IN} - V_{OUT}}{L} \times t_{ON}$$

EXAMPLE 5-3:

$$\begin{aligned} V_{IN} &= 12\text{V} \\ V_{OUT} &= 3.3\text{V} \\ I_{OUT} &= 500\text{ mA} \end{aligned}$$

EQUATION 5-5: INDUCTOR PEAK CURRENT

$$I_{LPK} = \frac{\Delta I_L}{2} + I_{OUT}$$

$$\begin{aligned} \text{Inductor Current Ripple} &= 319\text{ mA} \\ \text{Peak Inductor Current} &= 660\text{ mA} \end{aligned}$$

In case of the aforementioned example, an inductor saturation rating higher than 660 mA is recommended. Low DCR inductors result in higher system efficiency. A trade-off between size, cost and efficiency should be made to achieve the desired results.

TABLE 5-3: MCP16331 RECOMMENDED INDUCTORS FOR $V_{OUT} = 3.3V$

Part Number	Value (μH)	DCR (Ω)	I_{SAT} (A)	Size WxLxH (mm)
Coilcraft®				
ME3220-153	15	0.52	0.90	3.2x2.5x2.0
LPS4414-153	15	0.440	0.92	4.4x4.4x1.4
LPS6235-153	15	0.125	2.00	6.2x6.2x3.5
MSS6132-153	15	0.106	1.56	6.1x6.1x3.2
MSS7341-153	15	0.055	1.78	6.6x6.6x4.1
LPS3015-153	15	0.700	0.62	3.0x3.0x1.5
Würth Elektronik®				
74408942150	15	0.245	1.6	4.8x4.8x2.8
74437324150	15	0.375	2.1	4.06x4.45x1.8
74438356150	15	0.230	2.1	4.1x4.1x2.1
744025150	15	0.400	0.900	2.8x2.8x2.8
744042150	15	0.22	0.75	4.8x4.8x1.8
7447779115	15	0.081	2.2	7.3x7.3x4.5
TDK - EPCOS®				
VLS3012HBX-15 0M	15	0.636	1.52	3.0x3.0x1.2
VLS3015CX-150 M-H	15	0.428	0.57	3.0x3.0x1.5
VLS5045EX-150 M-H	15	0.110	2.2	5.0x5.3x4.5
B82462G4153M0 00	15	0.097	1.05	6.3x6.3x3.0
Eaton®				
SD12-150R	15	0.408	0.692	5.2x5.2x1.2
SD3118-150-R	15	0.44	0.75	3.2x3.2x1.8
SD52-150-R	15	0.161	0.88	5.2x5.5x2.0
Sumida®				
CDPH4D19FNP-150MC	15	0.075	0.66	5.2x5.2x2.0
CDRH3D28NP-1 50NC	15	0.170	0.9	4.0x4.0x3.0

TABLE 5-4: MCP16331 RECOMMENDED INDUCTORS FOR $V_{OUT} = 5V$

Part Number	Value (μH)	DCR (Ω)	I_{SAT} (A)	Size WxLxH (mm)
Coilcraft®				
ME3220-223	22	0.787	0.71	3.2x2.5x2.0
LPS4414-223	22	0.59	0.74	4.4x4.4x1.4
LPS6235-223	22	0.145	1.7	6.2x6.2x3.5
MSS6132-223	22	0.158	1.22	6.1x6.1x3.2
MSS7341-223	22	0.082	1.42	6.6x6.6x4.1
LPS3015-223	22	0.825	0.5	3.0x3.0x1.5
Würth Elektronik®				
74408942220	22	0.354	1.3	4.8x4.8x2.8
74437324220	22	0.500	2.0	4.06x4.45x1.8
74438356220	22	0.280	1.85	4.1x4.1x2.1
744025220	22	0.575	0.75	2.8x2.8x2.8
744042220	22	0.3	0.6	4.8x4.8x1.8
7447779122	22	0.11	1.7	7.3x7.3x4.5
TDK - EPCOS®				
VLS3012HBX-22 0M	22	0.761	1.09	3.0x3.0x1.2
VLS3015CX-220 M-H	22	0.660	0.45	3.0x3.0x1.5
VLS5045EX-150 M-H	22	0.162	2.0	5.0x5.3x4.5
82462G4223M00 0	22	0.15	0.85	6.3x6.3x3.0
Eaton®				
SD12-220-R	22	0.633	0.574	5.2x5.2x1.2
SD3118-220-R	22	0.676	0.61	3.2x3.2x1.8
SD52-220-R	22	0.204	0.73	5.2x5.2x2.0
Sumida®				
CDPH4D19FNP-2 20MC	22	0.135	0.54	5.2x5.2x2.0
CDRH3D16/HPN P-220MC	22	0.61	0.55	4.0x4.0x1.8

MCP16331

5.7 Freewheeling Diode

The freewheeling diode creates a path for inductor current flow after the internal switch is turned off. The average diode current is dependent upon the output load current and the duty cycle (D). The efficiency of the converter is a function of the forward drop and speed of the freewheeling diode. A low forward drop Schottky diode is recommended. The current rating and voltage rating of the diode is application-dependent. The diode voltage rating should be a minimum of V_{IN} plus margin. The average diode current can be calculated using [Equation 5-6](#).

EQUATION 5-6: DIODE AVERAGE CURRENT

$$I_{DAVG} = (I - D) \times I_{OUT}$$

EXAMPLE 5-4:

$$\begin{aligned} I_{OUT} &= 0.5A \\ V_{IN} &= 15V \\ V_{OUT} &= 5V \\ D &= 5/15 \\ I_{DAVG} &= 333 \text{ mA} \end{aligned}$$

In case of the aforementioned example, the usage of a 0.5A to 1A diode is suggested and a list of recommended freewheeling diodes is shown in [Table 5-5](#), below.

TABLE 5-5: FREEWHEELING DIODES

App	Mfr.	Part Number	Rating
12 V_{IN} , 500 mA	Diodes Inc.	DFLS120L-7	20V, 1A
24 V_{IN} , 100 mA	Diodes Inc.	B0540WS-7	40V, 0.5A
18 V_{IN} , 500 mA	Diodes Inc.	B130L-13-F	30V, 1A
48 V_{IN} , 500 mA	Diodes Inc.	B1100	100V, 1A

5.8 Boost Diode

The boost diode is used to provide a charging path from the low-voltage gate drive source while the switch node is low. The boost diode blocks the high voltage of the switch node from feeding back into the output voltage when the switch is turned on, forcing the switch node high.

A standard 1N4148 ultra-fast diode is recommended for its recovery speed, high voltage blocking capability, availability and cost. The voltage rating required for the boost diode should exceed V_{IN} .

For low boost voltage applications, a small Schottky diode with the appropriately rated voltage can be used to lower the forward drop, increasing the boost supply for the gate drive.

5.9 Boost Capacitor

The boost capacitor is used to supply current for the internal high-side drive circuitry that is above the input voltage. The boost capacitor must store enough energy to completely drive the high-side switch on and off. A 0.1 μF X5R or X7R capacitor is recommended for all applications. The boost capacitor maximum voltage is 5.5V, so a 6.3V or 10V rated capacitor is recommended. In case of a noise-sensitive application, an additional resistor, connected in series with the boost capacitor, that will reduce the high-frequency noise associated with switching power supplies can be added. A typical value for the resistor is 82 Ω .

5.10 Thermal Calculations

The MCP16331 device is available in the 6-lead SOT-23 and 8-lead TDFN packages. By calculating the power dissipation and applying the package thermal resistance (θ_{JA}), the junction temperature can be estimated.

To quickly estimate the internal power dissipation for the switching step-down regulator, an empirical calculation using measured efficiency can be used. Given the measured efficiency, the internal power dissipation is estimated by [Equation 5-7](#). This power dissipation includes all internal and external component losses. For a quick internal estimate, subtract the estimated Schottky diode loss and inductor DCR loss from the P_{DIS} calculation in [Equation 5-7](#).

EQUATION 5-7: TOTAL POWER DISSIPATION ESTIMATE

$$\left(\frac{V_{OUT} \times I_{OUT}}{\text{Efficiency}} \right) - (V_{OUT} \times I_{OUT}) = P_{Dis}$$

The difference between the first term, input power, and the second term, power delivered, is the total system power dissipation. The freewheeling Schottky diode losses are determined by calculating the average diode current and multiplying it by the diode forward drop. The inductor losses are estimated by $P_L = I_{OUT}^2 \times L_{DCR}$.

EQUATION 5-8: DIODE POWER DISSIPATION ESTIMATE

$$P_{Diode} = V_F \times ((I - D) \times I_{OUT})$$

EXAMPLE 5-5:

$$\begin{aligned}
 V_{IN} &= 10V \\
 V_{OUT} &= 5.0V \\
 I_{OUT} &= 0.4A \\
 \text{Efficiency} &= 90\% \\
 \text{Total System Dissipation} &= 222 \text{ mW} \\
 L_{DCR} &= 0.15\Omega \\
 P_L &= 24 \text{ mW} \\
 \text{Diode } V_F &= 0.50 \\
 D &= 50\% \\
 P_{Diode} &= 125 \text{ mW}
 \end{aligned}$$

MCP16331 internal power dissipation estimate:

$$P_{DIS} = P_L + P_{DIODE} = 73 \text{ mW}$$

$$\begin{aligned}
 \theta_{JA} &= 198^\circ\text{C/W} \\
 \text{Estimated Junction} &= +14.5^\circ\text{C} \\
 \text{Temperature Rise} &
 \end{aligned}$$

5.11 PCB Layout Information

Good printed circuit board layout techniques are important to any switching circuitry and switched-mode power supplies are no different. When wiring the switching high-current paths, short and wide traces should be used. Therefore, it is important that the input and output capacitors be placed as close as possible to the MCP16331, to minimize the loop area.

The feedback resistors and feedback signal should be routed away from the switching node, and the switching current loop. When possible, ground planes and traces should be used to help shield the feedback signal and minimize noise and magnetic interference.

A good MCP16331 layout starts with C_{IN} placement. C_{IN} supplies current to the input of the circuit when the switch is turned on. In addition to supplying high-frequency switch current, C_{IN} also provides a stable voltage source for the internal MCP16331 circuitry. Unstable PWM operation can result if there are excessive transients or ringing on the V_{IN} pin of the MCP16331 device. In [Figure 5-1](#), C_{IN} is placed close to pin 5. A ground plane on the bottom of the board provides a low resistive and inductive path for the return current. The next priority in placement is the freewheeling current loop formed by D1, C_{OUT} and L, while strategically placing the C_{OUT} return close to the C_{IN} return. Next, the boost capacitor should be placed between the boost pin and the switch node pin, SW. This leaves space close to the MCP16331 V_{FB} pin to place R_{TOP} and R_{BOT} . R_{TOP} and R_{BOT} are routed away from the switch node, so noise is not coupled into the high-impedance V_{FB} input.

MCP16331

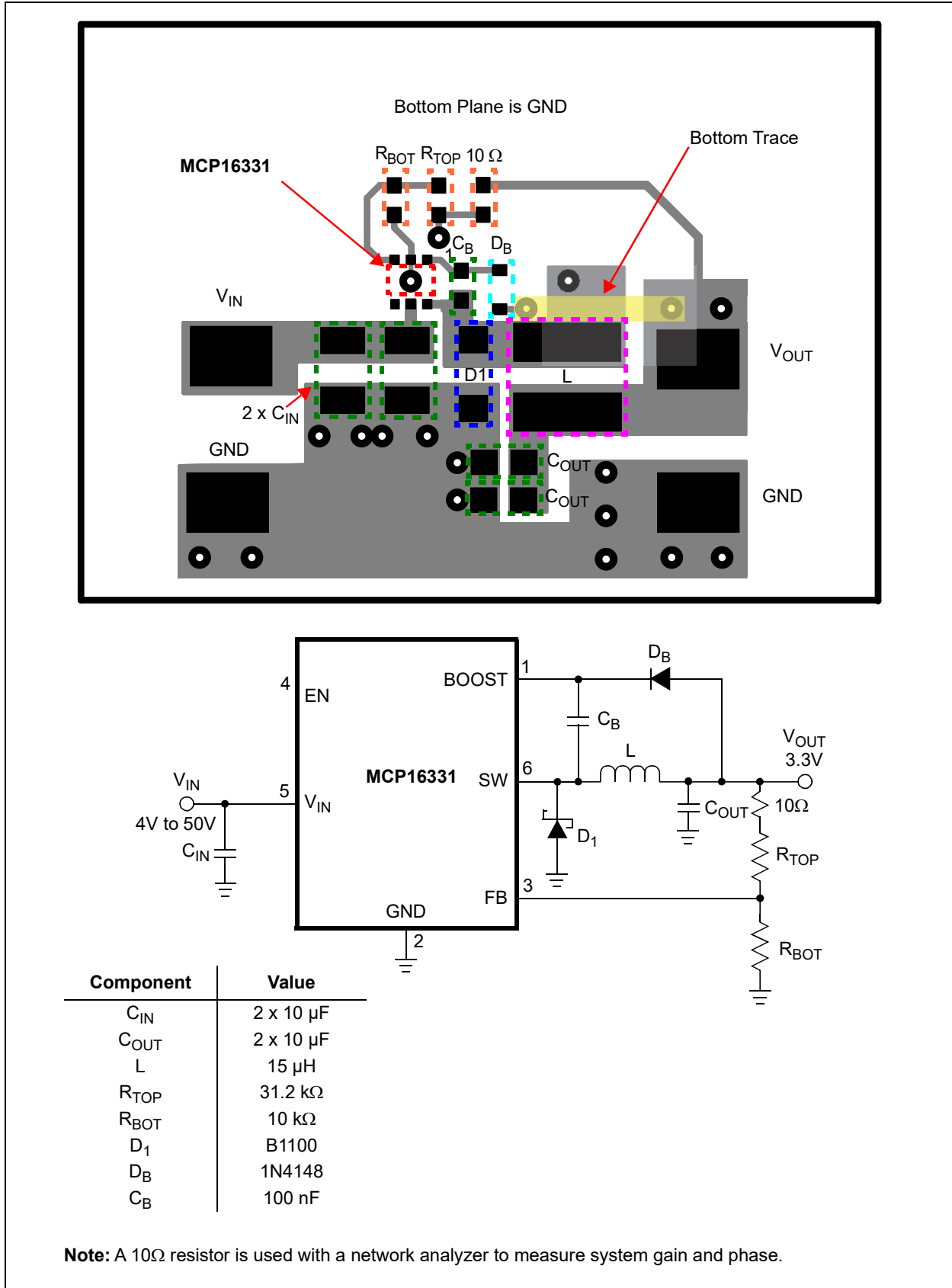

FIGURE 5-1: MCP16331 SOT-23-6 Recommended Layout, 500 mA Output Current Design.

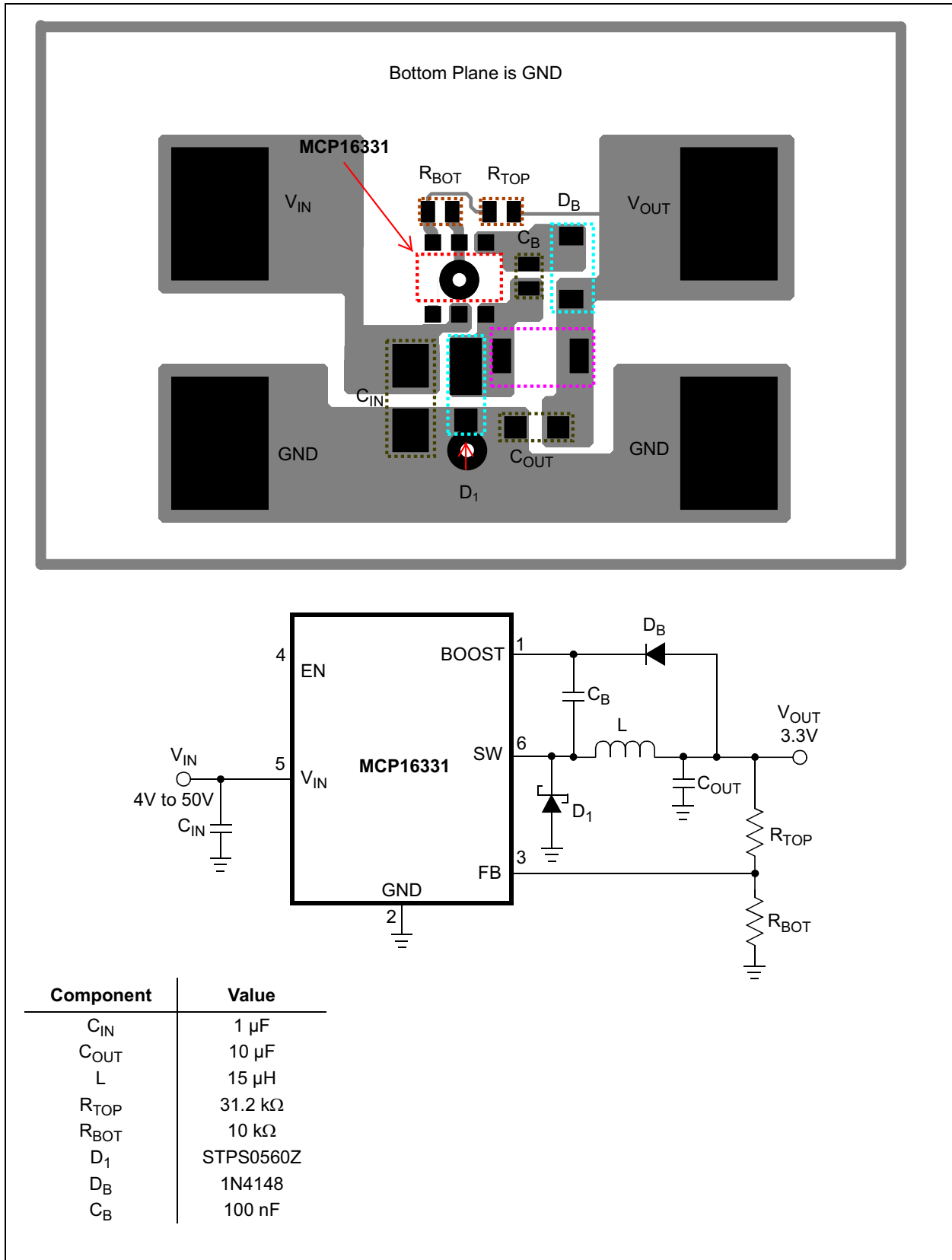

FIGURE 5-2: Compact MCP16331 SOT-23-6 Recommended Layout, Low-Current Design.

MCP16331

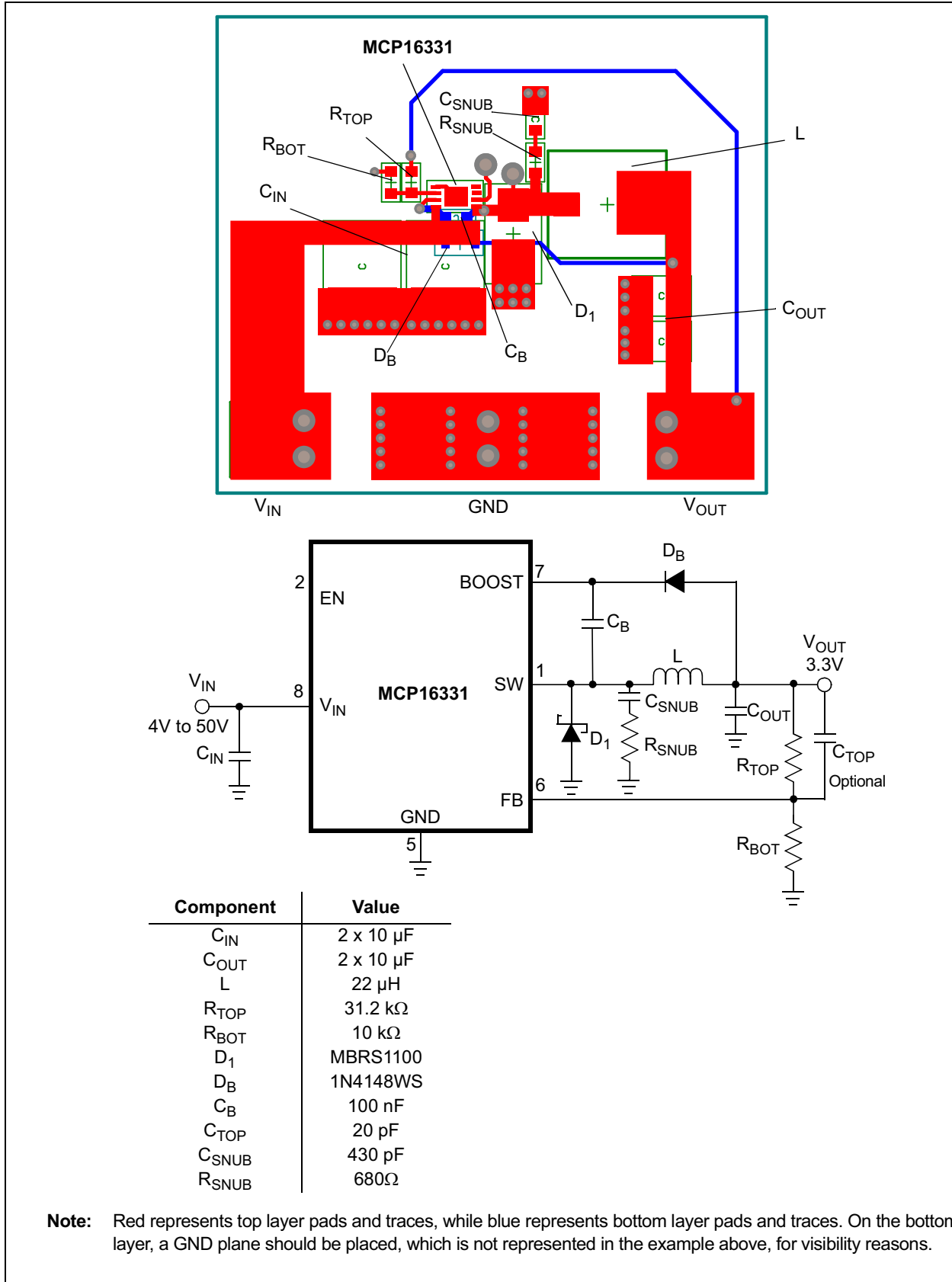

FIGURE 5-3: MCP16331 TDFN-8 Recommended Layout Design.

6.0 TYPICAL APPLICATION CIRCUITS

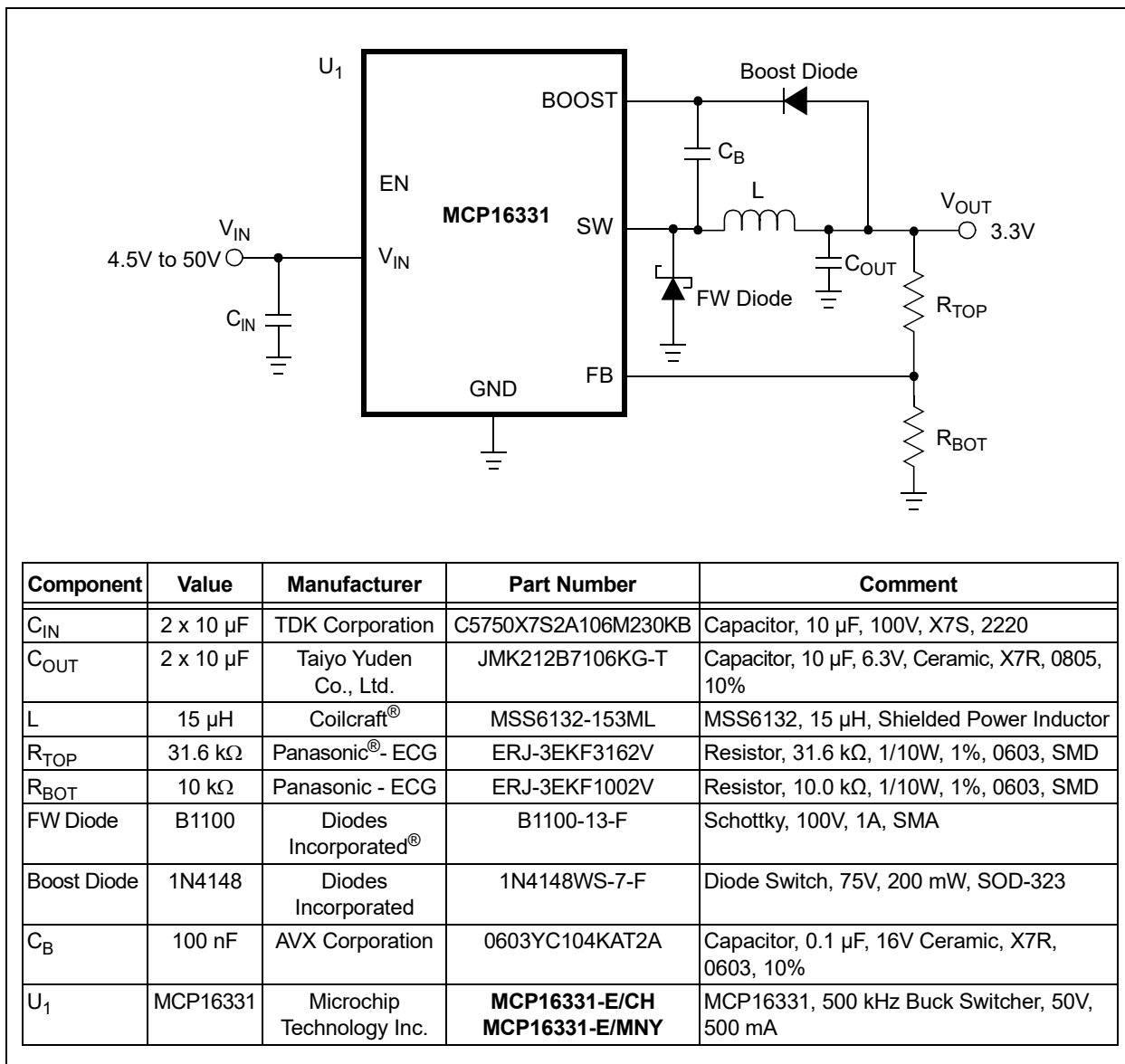

FIGURE 6-1: Typical Application, 4.5V – 50V V_{IN} to 3.3V V_{OUT} .

MCP16331

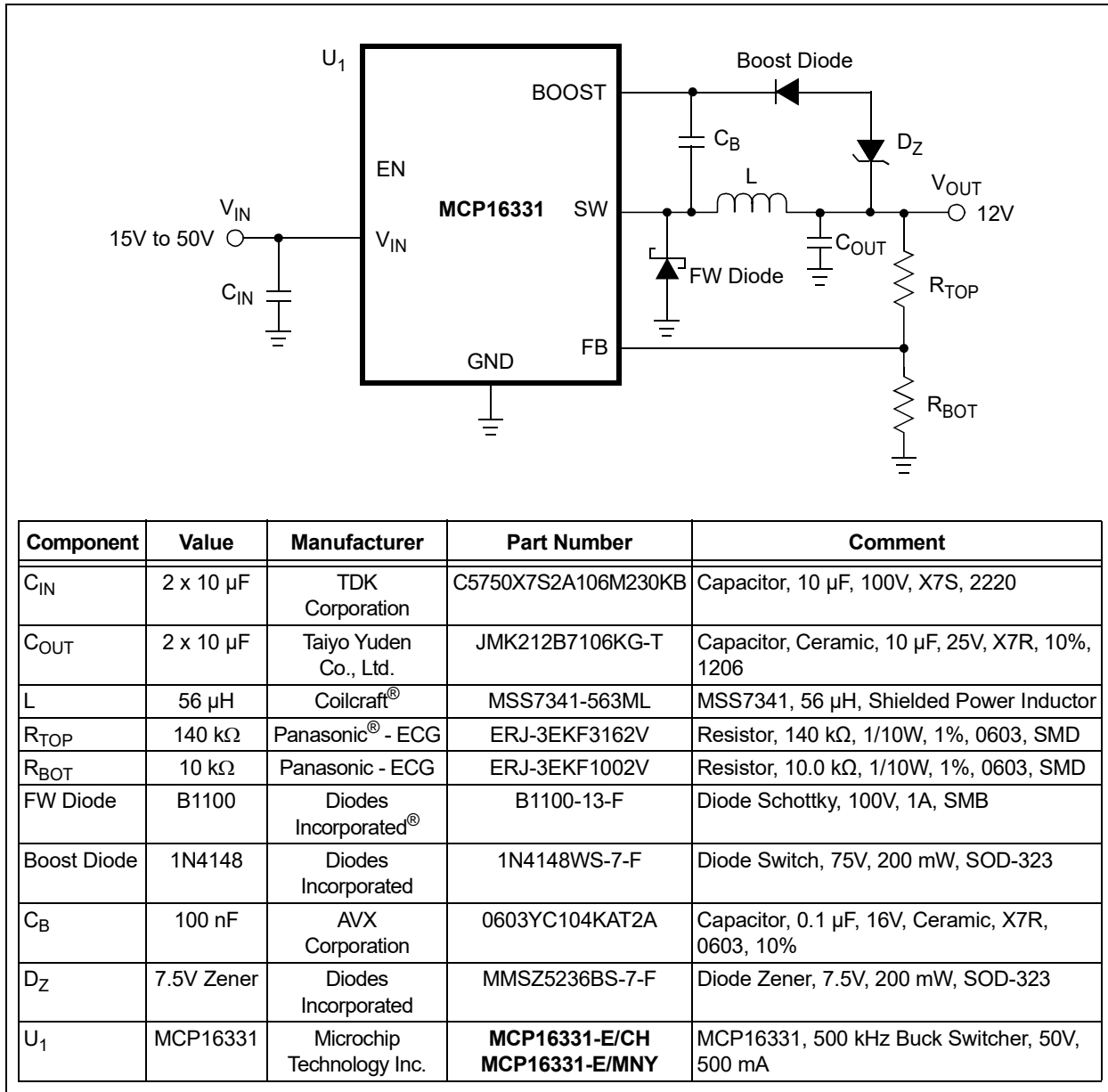

FIGURE 6-2: Typical Application, 15V – 50V Input; 12V Output.

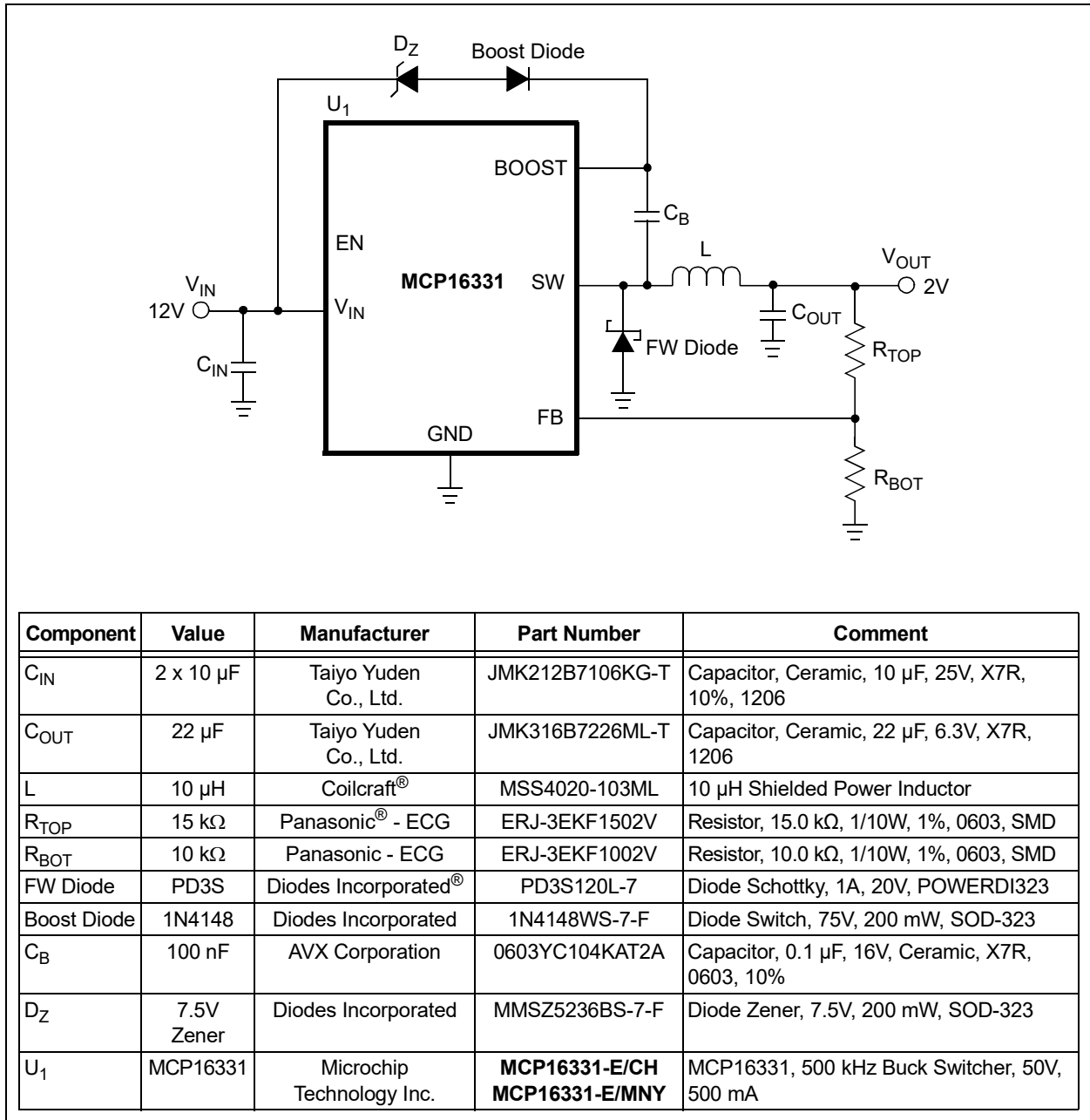

FIGURE 6-3: Typical Application, 12V Input; 2V Output at 500 mA.

MCP16331

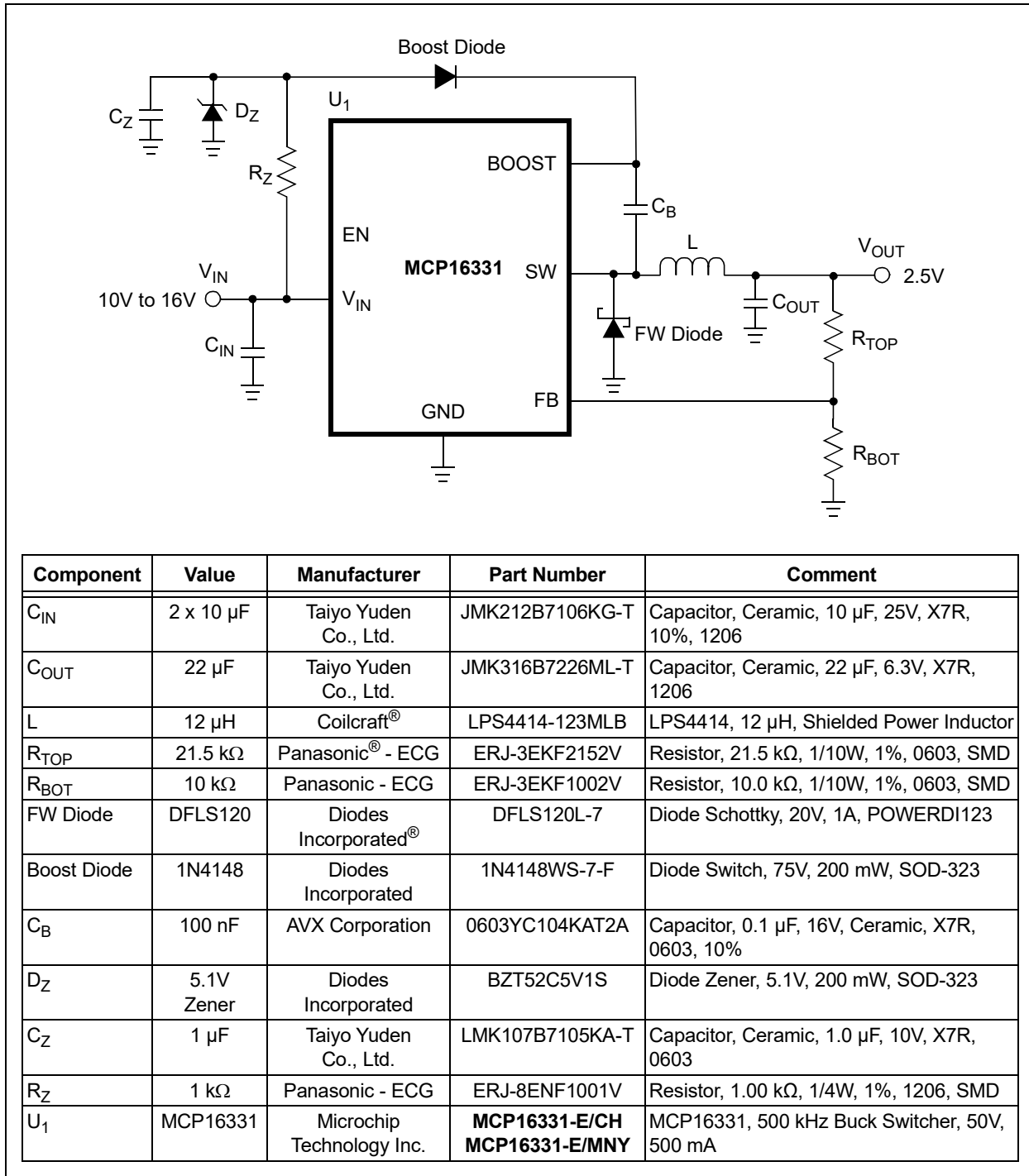

FIGURE 6-4: Typical Application, 10V to 16V V_{IN} ; 2.5V Output.

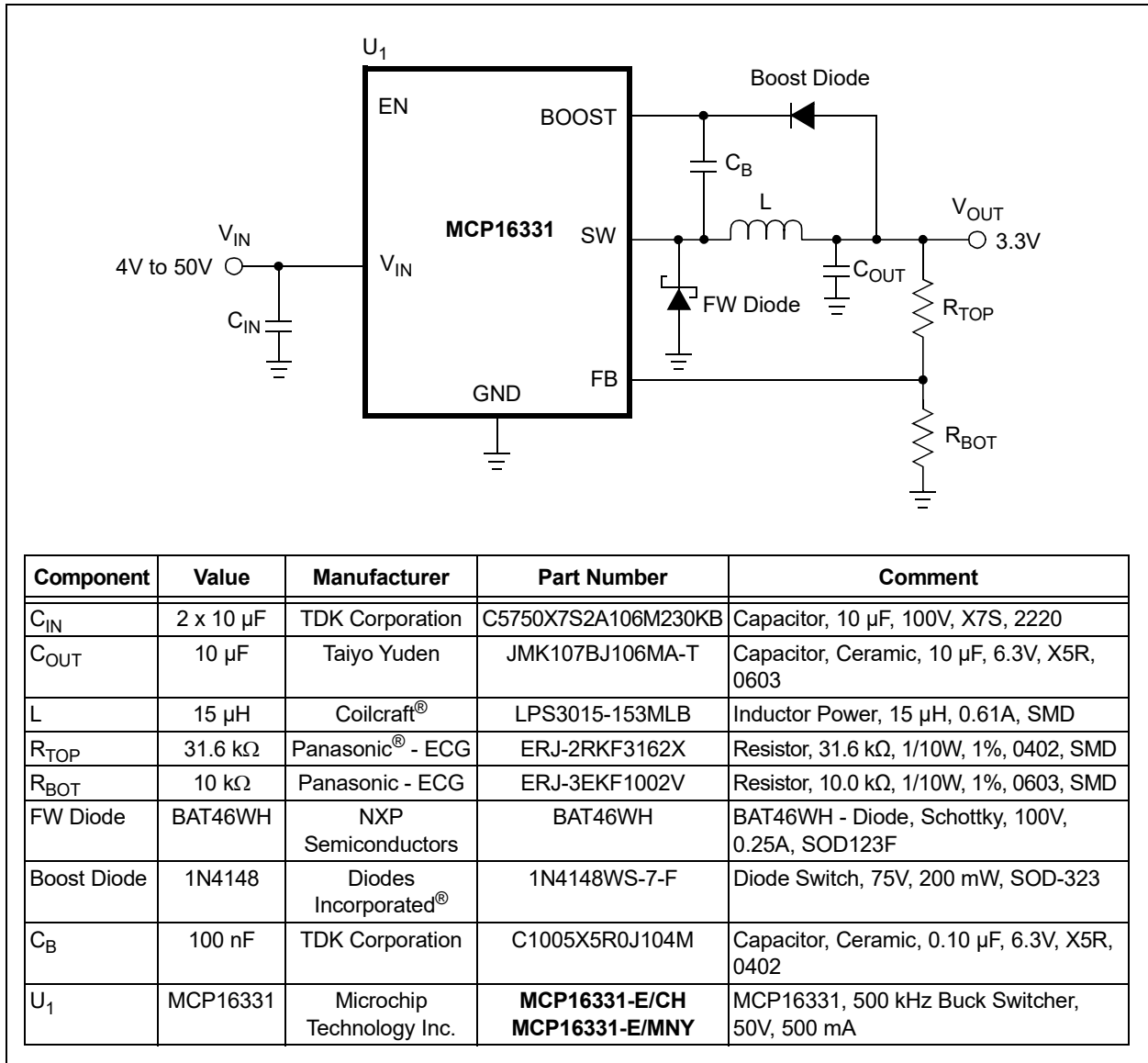

FIGURE 6-5: Typical Application, 4V – 50V V_{IN} to 3.3V V_{OUT} at 150 mA.

MCP16331

7.0 NON-TYPICAL APPLICATION CIRCUITS

For additional information, please refer to the Application Note: AN2102 “Designing Applications with MCP16331 High-Input Voltage Buck Converter” (DS00002102), which can be found on the www.microchip.com web site.

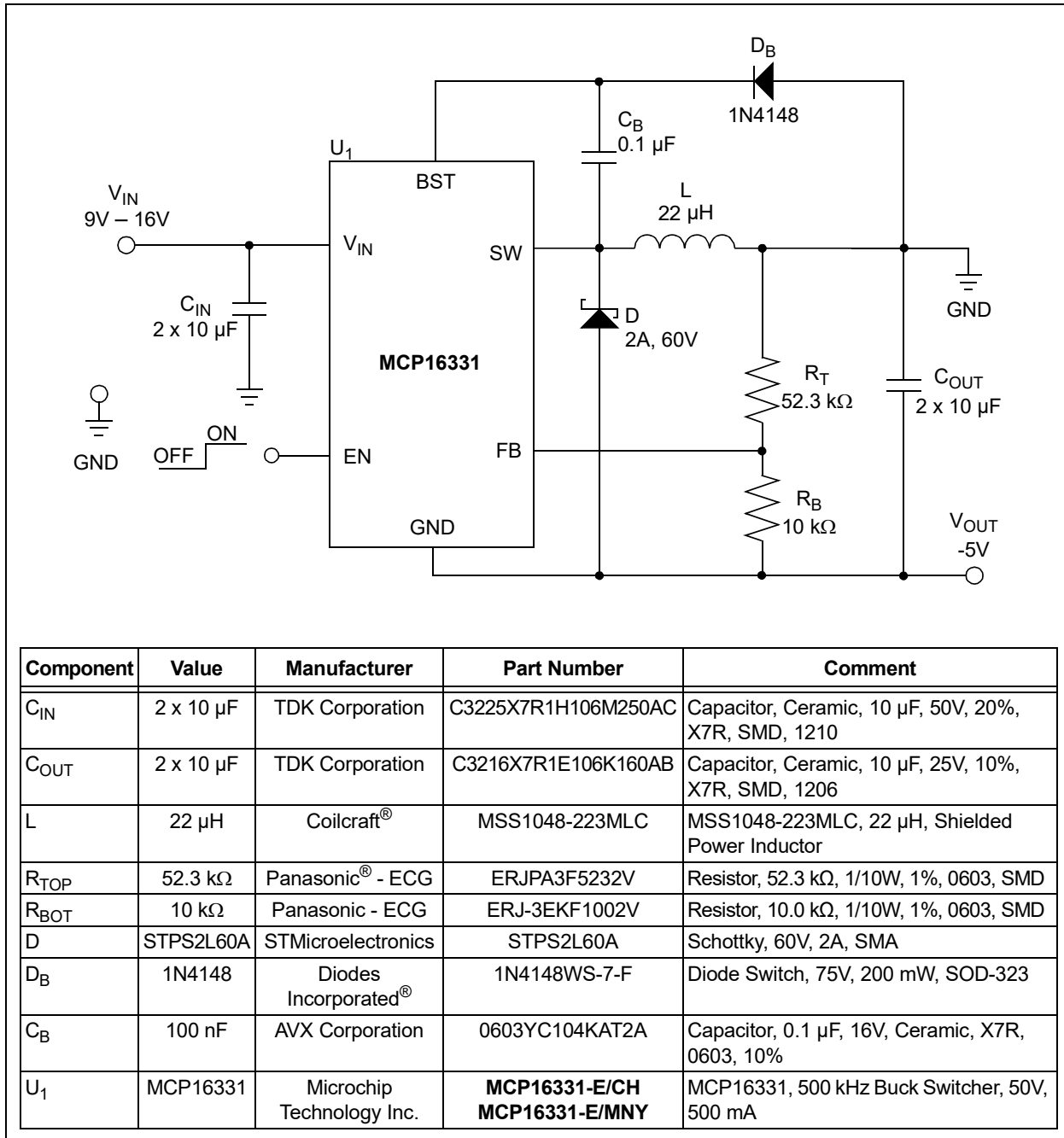

FIGURE 7-1: Inverting Buck-Boost Application, 9V – 16V V_{IN} to -5V V_{OUT}.

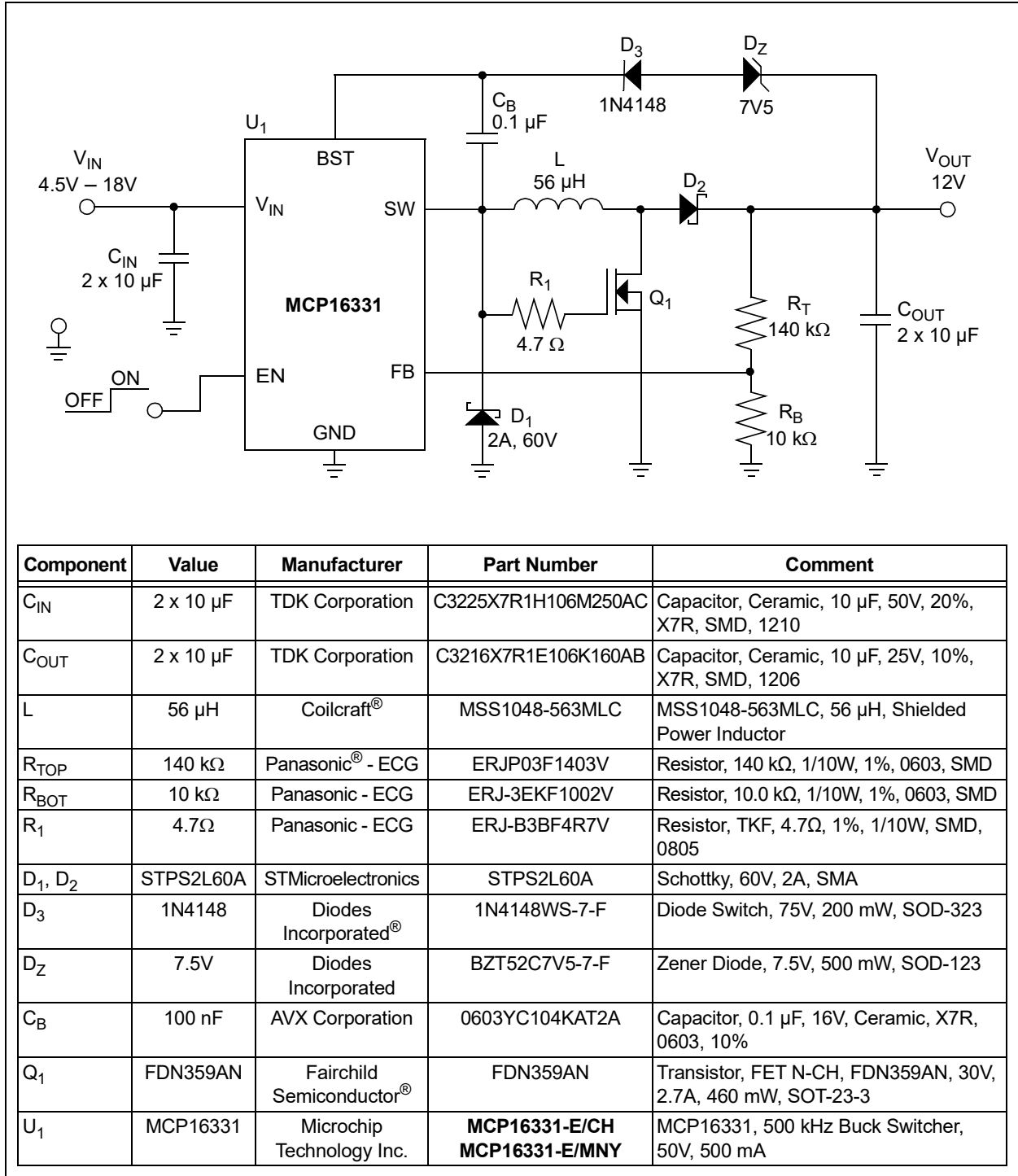
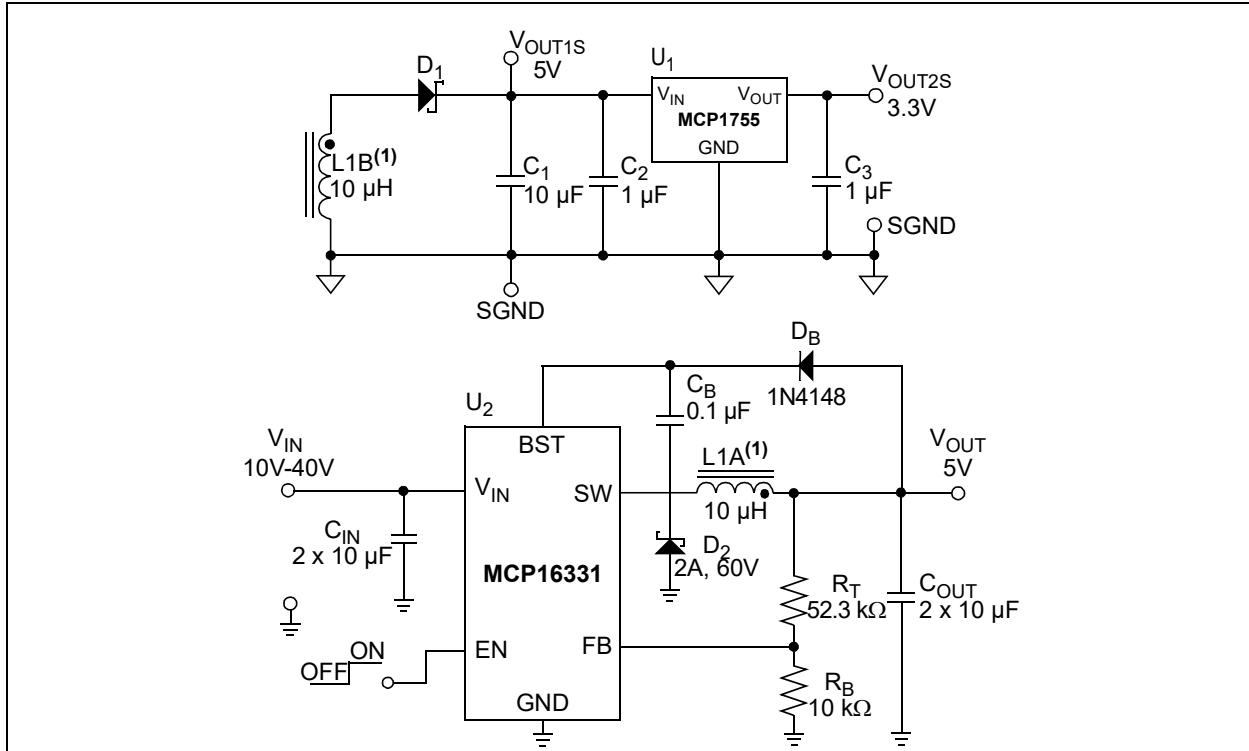

FIGURE 7-2: Non-Inverting Buck-Boost Application, 4.5V – 18V V_{IN} to 12V V_{OUT}.

MCP16331



- Note 1:** L1A and L1B are mutually coupled.
- 2:** Please refer to the Application Note: AN2102 “*Designing Applications with MCP16331 High-Input Voltage Buck Converter*” (DS00002102), which can be found on the www.microchip.com web site.

Component	Value	Manufacturer	Part Number	Comment
C _{IN}	2 x 10 µF	TDK Corporation	C3225X7R1H106M250AC	Capacitor, Ceramic, 10 µF, 50V, 20%, X7R, SMD, 1210
C _{OUT} , C ₁	10 µF	TDK Corporation	C3216X7R1E106K160AB	Capacitor, Ceramic, 10 µF, 25V, 10%, X7R, SMD, 1206
C ₂ , C ₃	1 µF	TDK Corporation	CGA4J3X7R1E105K125AB	Capacitor, Ceramic, 1 µF, 25V, 10%, X7R, SMD, 0805
L ₁	10 µH	Würth Elektronik®	744874100	744874100, 10 µH, Shielded Coupled Inductors
R _T	52.3 kΩ	Panasonic® - ECG	ERJPA3F5232V	Resistor, 52.3 kΩ, 1/10W, 1%, 0603, SMD
R _B	10 kΩ	Panasonic - ECG	ERJ-3EKF1002V	Resistor, 10.0 kΩ, 1/10W, 1%, 0603, SMD
D ₁	MBR0530	Fairchild Semiconductor®	MBR0530	Schottky Rectifier, 30V, 500 mA, SOD-123
D ₂	STPS2L60A	STMicroelectronics	STPS2L60A	Schottky, 60V, 2A, SMA
D _B	1N4148	Diodes Incorporated®	1N4148WS-7-F	Diode Switch, 75V, 200 mW, SOD-323
C _B	100 nF	AVX Corporation	0603YC104KAT2A	Capacitor, 0.1 µF, 16V, Ceramic, X7R, 0603, 10%
U ₁	MCP1755	Microchip Technology Inc.	MCP1755S-3302E/DB	MCP1755, 3.3V LDO, 300 mA, SOT-223-3
U _s	MCP16331	Microchip Technology Inc.	MCP16331-E/CH MCP16331-E/MNY	MCP16331, 500 kHz Buck Switcher, 50V, 500 mA

FIGURE 7-3: Multiple Outputs Buck Converter 10V – 40V Input Voltage to 2 x 5V and 3.3V Output Voltages.⁽²⁾

8.0 PACKAGING INFORMATION

8.1 Package Marking Information

6-Lead SOT-23

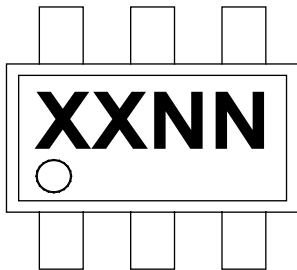

Example

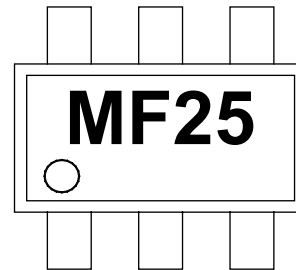

8-Lead TDFN (2x3x0.75 mm)

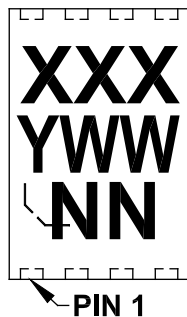

Example

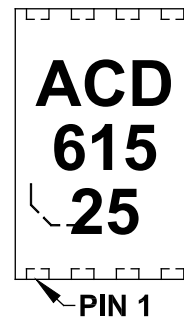

Legend:	XX...X	Customer-specific information
	Y	Year code (last digit of calendar year)
	YY	Year code (last 2 digits of calendar year)
	WW	Week code (week of January 1 is week '01')
	NNN	Alphanumeric traceability code
	(e3)	Pb-free JEDEC® designator for Matte Tin (Sn)
	*	This package is Pb-free. The Pb-free JEDEC designator (e3) can be found on the outer packaging for this package.

Note: In the event the full Microchip part number cannot be marked on one line, it will be carried over to the next line, thus limiting the number of available characters for customer-specific information.

MCP16331

6-Lead Plastic Small Outline Transistor (CH, CHY) [SOT-23]

Note: For the most current package drawings, please see the Microchip Packaging Specification located at <http://www.microchip.com/packaging>

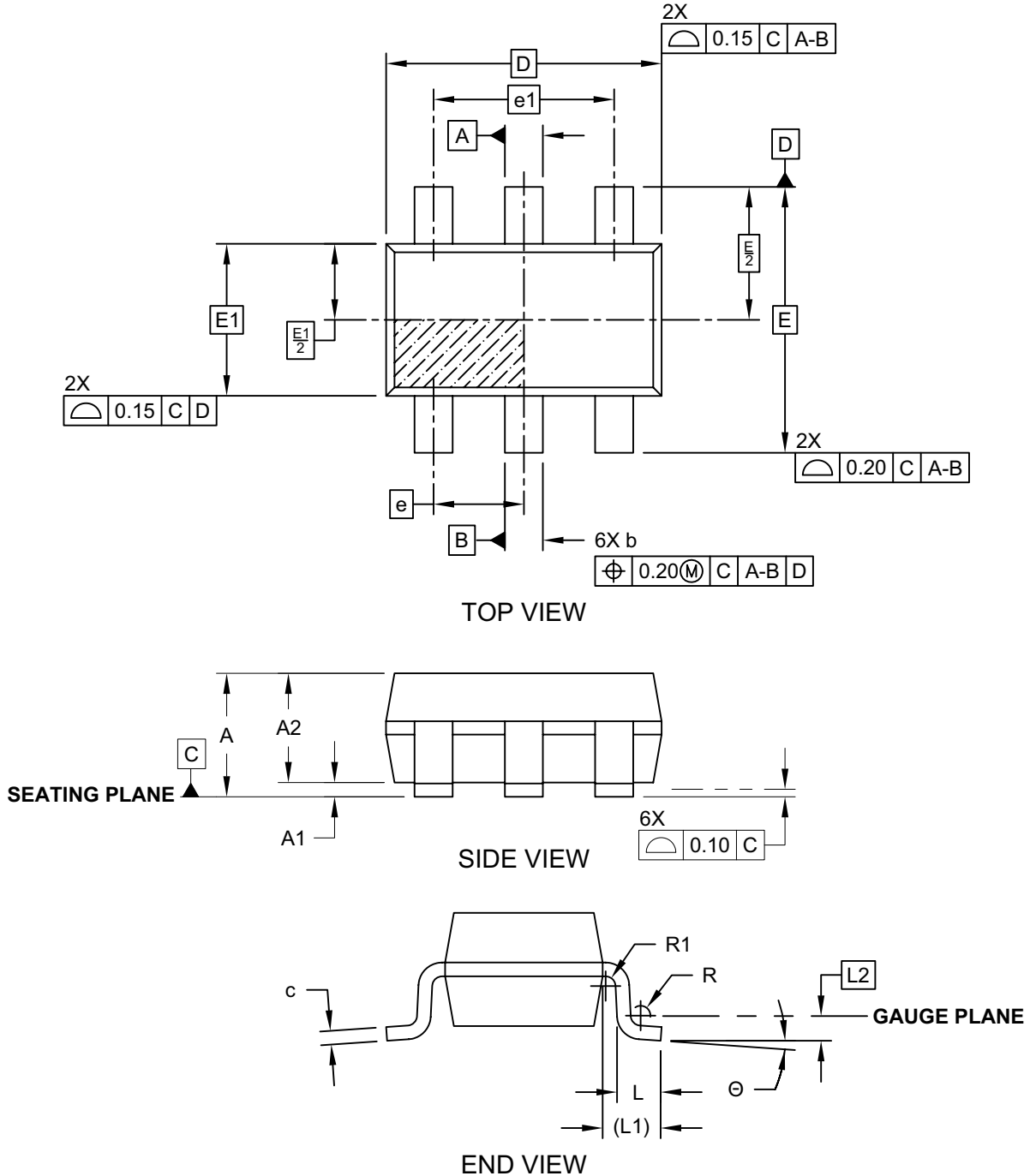

Microchip Technology Drawing C04-028C (CH) Sheet 1 of 2

6-Lead Plastic Small Outline Transistor (CH, CHY) [SOT-23]

Note: For the most current package drawings, please see the Microchip Packaging Specification located at <http://www.microchip.com/packaging>

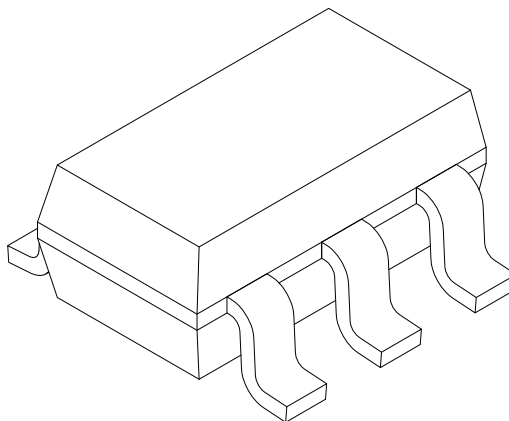

Dimension Limits	Units	MILLIMETERS		
		MIN	NOM	MAX
Number of Leads	N	6		
Pitch	e	0.95 BSC		
Outside lead pitch	e1	1.90 BSC		
Overall Height	A	0.90	-	1.45
Molded Package Thickness	A2	0.89	1.15	1.30
Standoff	A1	0.00	-	0.15
Overall Width	E	2.80 BSC		
Molded Package Width	E1	1.60 BSC		
Overall Length	D	2.90 BSC		
Foot Length	L	0.30	0.45	0.60
Footprint	L1	0.60 REF		
Seating Plane to Gauge Plane	L1	0.25 BSC		
Foot Angle	φ	0°	-	10°
Lead Thickness	c	0.08	-	0.26
Lead Width	b	0.20	-	0.51

Notes:

- Dimensions D and E1 do not include mold flash or protrusions. Mold flash or protrusions shall not exceed 0.25mm per side.
- Dimensioning and tolerancing per ASME Y14.5M
 BSC: Basic Dimension. Theoretically exact value shown without tolerances.
 REF: Reference Dimension, usually without tolerance, for information purposes only.

Microchip Technology Drawing C04-028C (CH) Sheet 2 of 2

MCP16331

6-Lead Plastic Small Outline Transistor (CH, CHY) [SOT-23]

Note: For the most current package drawings, please see the Microchip Packaging Specification located at <http://www.microchip.com/packaging>

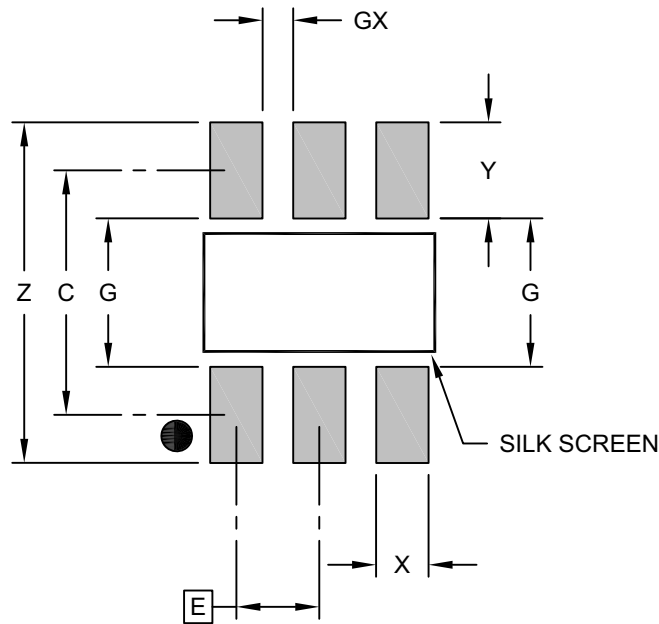

RECOMMENDED LAND PATTERN

Dimension Limits	Units	MILLIMETERS		
		MIN	NOM	MAX
Contact Pitch	E	0.95 BSC		
Contact Pad Spacing	C		2.80	
Contact Pad Width (X3)	X			0.60
Contact Pad Length (X3)	Y			1.10
Distance Between Pads	G	1.70		
Distance Between Pads	GX	0.35		
Overall Width	Z			3.90

Notes:

1. Dimensioning and tolerancing per ASME Y14.5M

BSC: Basic Dimension. Theoretically exact value shown without tolerances.

Microchip Technology Drawing No. C04-2028B (CH)

8-Lead Plastic Dual Flat, No Lead Package (MNY) – 2x3x0.8 mm Body [TDFN] With 1.4x1.3 mm Exposed Pad (JEDEC Package type WDFN)

Note: For the most current package drawings, please see the Microchip Packaging Specification located at <http://www.microchip.com/packaging>

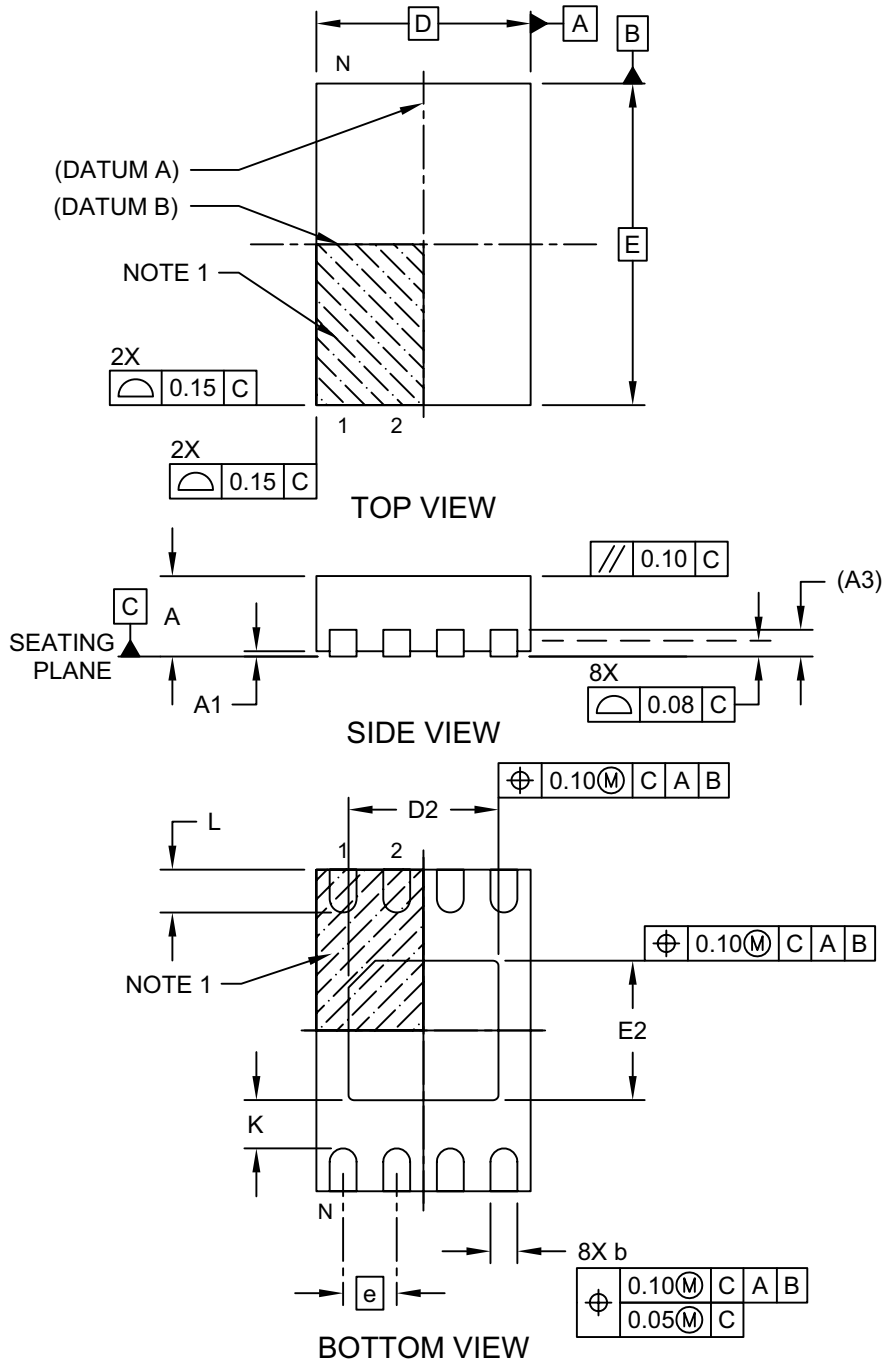

Microchip Technology Drawing No. C04-129-MNY Rev E Sheet 1 of 2

MCP16331

8-Lead Plastic Dual Flat, No Lead Package (MNY) – 2x3x0.8 mm Body [TDFN] With 1.4x1.3 mm Exposed Pad (JEDEC Package type WDFN)

Note: For the most current package drawings, please see the Microchip Packaging Specification located at <http://www.microchip.com/packaging>

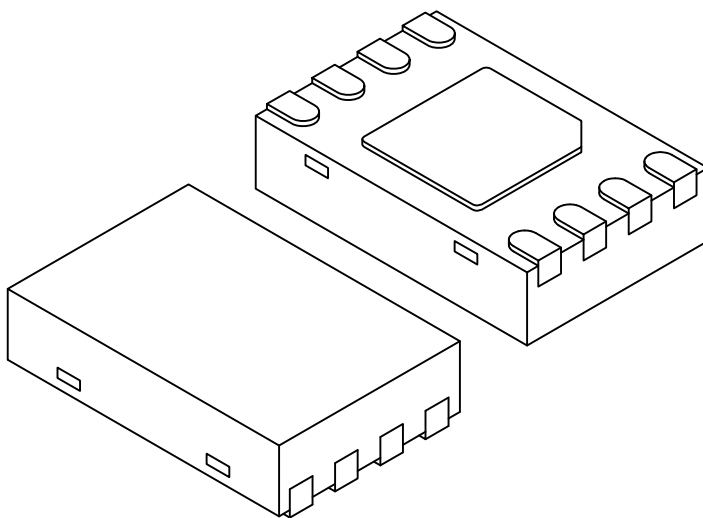

Dimension Limits	Units	MILLIMETERS		
		MIN	NOM	MAX
Number of Pins	N	8		
Pitch	e	0.50 BSC		
Overall Height	A	0.70	0.75	0.80
Standoff	A1	0.00	0.02	0.05
Contact Thickness	A3	0.20 REF		
Overall Length	D	2.00 BSC		
Overall Width	E	3.00 BSC		
Exposed Pad Length	D2	1.35	1.40	1.45
Exposed Pad Width	E2	1.25	1.30	1.35
Contact Width	b	0.20	0.25	0.30
Contact Length	L	0.25	0.30	0.45
Contact-to-Exposed Pad	K	0.20	-	-

Notes:

1. Pin 1 visual index feature may vary, but must be located within the hatched area.
2. Package may have one or more exposed tie bars at ends.
3. Package is saw singulated
4. Dimensioning and tolerancing per ASME Y14.5M

BSC: Basic Dimension. Theoretically exact value shown without tolerances.

REF: Reference Dimension, usually without tolerance, for information purposes only.

Microchip Technology Drawing No. C04-129-MNY Rev E Sheet 2 of 2

8-Lead Plastic Dual Flat, No Lead Package (MNY) – 2x3x0.8 mm Body [TDFN] With 1.4x1.3 mm Exposed Pad (JEDEC Package type WDFN)

Note: For the most current package drawings, please see the Microchip Packaging Specification located at <http://www.microchip.com/packaging>

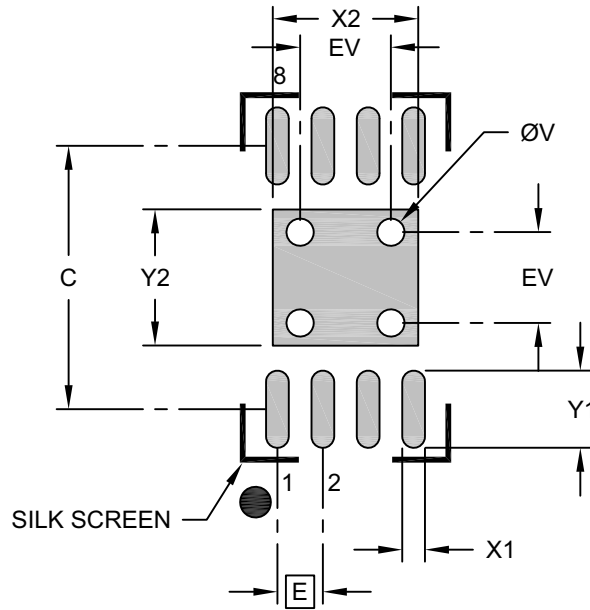

RECOMMENDED LAND PATTERN

Dimension Limits	Units	MILLIMETERS		
		MIN	NOM	MAX
Contact Pitch	E	0.50 BSC		
Optional Center Pad Width	X2			1.60
Optional Center Pad Length	Y2			1.50
Contact Pad Spacing	C		2.90	
Contact Pad Width (X8)	X1			0.25
Contact Pad Length (X8)	Y1			0.85
Thermal Via Diameter	V		0.30	
Thermal Via Pitch	EV		1.00	

Notes:

- Dimensioning and tolerancing per ASME Y14.5M
BSC: Basic Dimension. Theoretically exact value shown without tolerances.
- For best soldering results, thermal vias, if used, should be filled or tented to avoid solder loss during reflow process

Microchip Technology Drawing No. C04-129-MNY Rev. B

MCP16331

NOTES:

APPENDIX A: REVISION HISTORY

Revision D (January 2021)

The following is a list of modifications:

1. Added the Automotive AEC-Q100 Reliability Testing information in the [Features](#) section on page 1.
2. Updated [Table 5-3](#) and [Table 5-4](#).
3. Updated the [Product Identification System](#) section with the Automotive AEC-Q100 Qualification information and corresponding part number.

Revision C (December 2016)

The following is a list of modifications:

1. Updated [Section 6.0 “Typical Application Circuits”](#).
2. Added [Section 7.0 “Non-Typical Application Circuits”](#).
3. Minor typographical corrections.

Revision B (October 2014)

The following is a list of modifications:

1. Added edits to incorporate the AEC-Q100 qualification.

Revision A (June 2014)

- Original release of this document.

MCP16331

NOTES:

PRODUCT IDENTIFICATION SYSTEM

To order or obtain information, e.g., on pricing or delivery, refer to the factory or the listed sales office.

<u>PART NO.</u>	<u>IX1</u> ⁽¹⁾	<u>X</u>	<u>IXX</u>	<u>XXX</u>	Examples:
Device	Tape and Reel Option	Temperature Range	Package	Qualification	
<p>Device:</p> <p>MCP16331: High-Voltage Input Integrated Switch Step-Down Regulator</p> <p>MCP16331T: High-Voltage Input Integrated Switch Step-Down Regulator (Tape and Reel)</p>					<p>a) MCP16331T-E/CH: Tape and Reel, Extended Temperature, 6-Lead SOT-23 package</p> <p>b) MCP16331T-E/CHVAO: Tape and Reel, Extended Temperature, 6-Lead SOT-23 package, AEC-Q100 Qualified</p> <p>c) MCP16331T-E/MNY: Tape and Reel, Extended Temperature, 8-Lead TDFN package</p>
<p>Tape and Reel Option:</p> <p>T = Tape and Reel⁽¹⁾</p>					
<p>Temperature Range:</p> <p>E = -40°C to +125°C</p>					
<p>Package:</p> <p>CH = Plastic Small Outline Transistor, SOT-23, 6-Lead</p> <p>MNY* = Plastic Dual Flat TDFN, 8-Lead</p> <p>*Y = Nickel palladium gold manufacturing designator. Only available on the TDFN package.</p>					
<p>Package:</p> <p>(Blank) = Standard Qualification</p> <p>VAO = AEC-Q100 Automotive Qualification</p>					
<p>Note 1: Tape and Reel identifier only appears in the catalog part number description. This identifier is used for ordering purposes and is not printed on the device package. Check with your Microchip Sales Office for package availability with the Tape and Reel option.</p>					

MCP16331

NOTES:

Note the following details of the code protection feature on Microchip devices:

- Microchip products meet the specifications contained in their particular Microchip Data Sheet.
- Microchip believes that its family of products is secure when used in the intended manner and under normal conditions.
- There are dishonest and possibly illegal methods being used in attempts to breach the code protection features of the Microchip devices. We believe that these methods require using the Microchip products in a manner outside the operating specifications contained in Microchip's Data Sheets. Attempts to breach these code protection features, most likely, cannot be accomplished without violating Microchip's intellectual property rights.
- Microchip is willing to work with any customer who is concerned about the integrity of its code.
- Neither Microchip nor any other semiconductor manufacturer can guarantee the security of its code. Code protection does not mean that we are guaranteeing the product is "unbreakable." Code protection is constantly evolving. We at Microchip are committed to continuously improving the code protection features of our products. Attempts to break Microchip's code protection feature may be a violation of the Digital Millennium Copyright Act. If such acts allow unauthorized access to your software or other copyrighted work, you may have a right to sue for relief under that Act.

Information contained in this publication is provided for the sole purpose of designing with and using Microchip products. Information regarding device applications and the like is provided only for your convenience and may be superseded by updates. It is your responsibility to ensure that your application meets with your specifications.

THIS INFORMATION IS PROVIDED BY MICROCHIP "AS IS". MICROCHIP MAKES NO REPRESENTATIONS OR WARRANTIES OF ANY KIND WHETHER EXPRESS OR IMPLIED, WRITTEN OR ORAL, STATUTORY OR OTHERWISE, RELATED TO THE INFORMATION INCLUDING BUT NOT LIMITED TO ANY IMPLIED WARRANTIES OF NON-INFRINGEMENT, MERCHANTABILITY, AND FITNESS FOR A PARTICULAR PURPOSE OR WARRANTIES RELATED TO ITS CONDITION, QUALITY, OR PERFORMANCE.

IN NO EVENT WILL MICROCHIP BE LIABLE FOR ANY INDIRECT, SPECIAL, PUNITIVE, INCIDENTAL OR CONSEQUENTIAL LOSS, DAMAGE, COST OR EXPENSE OF ANY KIND WHATSOEVER RELATED TO THE INFORMATION OR ITS USE, HOWEVER CAUSED, EVEN IF MICROCHIP HAS BEEN ADVISED OF THE POSSIBILITY OR THE DAMAGES ARE FORESEEABLE. TO THE FULLEST EXTENT ALLOWED BY LAW, MICROCHIP'S TOTAL LIABILITY ON ALL CLAIMS IN ANY WAY RELATED TO THE INFORMATION OR ITS USE WILL NOT EXCEED THE AMOUNT OF FEES, IF ANY, THAT YOU HAVE PAID DIRECTLY TO MICROCHIP FOR THE INFORMATION. Use of Microchip devices in life support and/or safety applications is entirely at the buyer's risk, and the buyer agrees to defend, indemnify and hold harmless Microchip from any and all damages, claims, suits, or expenses resulting from such use. No licenses are conveyed, implicitly or otherwise, under any Microchip intellectual property rights unless otherwise stated.

Trademarks

The Microchip name and logo, the Microchip logo, Adaptec, AnyRate, AVR, AVR logo, AVR Freaks, BesTime, BitCloud, chipKIT, chipKIT logo, CryptoMemory, CryptoRF, dsPIC, FlashFlex, flexPWR, HELDO, IGL00, JukeBlox, KeeLoq, Kleer, LANCheck, LinkMD, maXStylus, maXTouch, MediaLB, megaAVR, Microsemi, Microsemi logo, MOST, MOST logo, MPLAB, OptoLyzr, PackeTime, PIC, picoPower, PICSTART, PIC32 logo, PolarFire, Prochip Designer, QTouch, SAM-BA, SenGenuity, SpyNIC, SST, SST Logo, SuperFlash, Symmetricom, SyncServer, Tachyon, TimeSource, tinyAVR, UNI/O, Vectron, and XMEGA are registered trademarks of Microchip Technology Incorporated in the U.S.A. and other countries.

AgileSwitch, APT, ClockWorks, The Embedded Control Solutions Company, EtherSynch, FlashTec, Hyper Speed Control, HyperLight Load, IntelliMOS, Libero, motorBench, mTouch, Powermite 3, Precision Edge, ProASIC, ProASIC Plus, ProASIC Plus logo, Quiet-Wire, SmartFusion, SyncWorld, Temux, TimeCesium, TimeHub, TimePictra, TimeProvider, WinPath, and ZL are registered trademarks of Microchip Technology Incorporated in the U.S.A.

Adjacent Key Suppression, AKS, Analog-for-the-Digital Age, Any Capacitor, AnyIn, AnyOut, Augmented Switching, BlueSky, BodyCom, CodeGuard, CryptoAuthentication, CryptoAutomotive, CryptoCompanion, CryptoController, dsPICDEM, dsPICDEM.net, Dynamic Average Matching, DAM, ECAN, Espresso T1S, EtherGREEN, IdealBridge, In-Circuit Serial Programming, ICSP, INICnet, Intelligent Paralleling, Inter-Chip Connectivity, JitterBlocker, maxCrypto, maxView, memBrain, Mindi, MiWi, MPASM, MPF, MPLAB Certified logo, MPLIB, MPLINK, MultiTRAK, NetDetach, Omniscient Code Generation, PICDEM, PICDEM.net, PICkit, PICtail, PowerSmart, PureSilicon, QMatrix, REAL ICE, Ripple Blocker, RTAX, RTG4, SAM-ICE, Serial Quad I/O, simpleMAP, SimpliPHY, SmartBuffer, SMART-I.S., storClad, SQI, SuperSwitcher, SuperSwitcher II, Switchtec, SynchroPHY, Total Endurance, TSHARC, USBCheck, VariSense, VectorBlox, VeriPHY, ViewSpan, WiperLock, XpressConnect, and ZENA are trademarks of Microchip Technology Incorporated in the U.S.A. and other countries.

SQTP is a service mark of Microchip Technology Incorporated in the U.S.A.

The Adaptec logo, Frequency on Demand, Silicon Storage Technology, and Symmcom are registered trademarks of Microchip Technology Inc. in other countries.

GestIC is a registered trademark of Microchip Technology Germany II GmbH & Co. KG, a subsidiary of Microchip Technology Inc., in other countries.

All other trademarks mentioned herein are property of their respective companies.

© 2014-2021, Microchip Technology Incorporated, All Rights Reserved.

ISBN:978-1-5224-7492-0

For information regarding Microchip's Quality Management Systems, please visit www.microchip.com/quality.



MICROCHIP

Worldwide Sales and Service

AMERICAS

Corporate Office
2355 West Chandler Blvd.
Chandler, AZ 85224-6199
Tel: 480-792-7200
Fax: 480-792-7277
Technical Support:
<http://www.microchip.com/support>
Web Address:
www.microchip.com

Atlanta
Duluth, GA
Tel: 678-957-9614
Fax: 678-957-1455

Austin, TX
Tel: 512-257-3370

Boston
Westborough, MA
Tel: 774-760-0087
Fax: 774-760-0088

Chicago
Itasca, IL
Tel: 630-285-0071
Fax: 630-285-0075

Dallas
Addison, TX
Tel: 972-818-7423
Fax: 972-818-2924

Detroit
Novi, MI
Tel: 248-848-4000

Houston, TX
Tel: 281-894-5983

Indianapolis
Noblesville, IN
Tel: 317-773-8323
Fax: 317-773-5453
Tel: 317-536-2380

Los Angeles
Mission Viejo, CA
Tel: 949-462-9523
Fax: 949-462-9608
Tel: 951-273-7800

Raleigh, NC
Tel: 919-844-7510

New York, NY
Tel: 631-435-6000

San Jose, CA
Tel: 408-735-9110
Tel: 408-436-4270

Canada - Toronto
Tel: 905-695-1980
Fax: 905-695-2078

ASIA/PACIFIC

Australia - Sydney
Tel: 61-2-9868-6733

China - Beijing
Tel: 86-10-8569-7000

China - Chengdu
Tel: 86-28-8665-5511

China - Chongqing
Tel: 86-23-8980-9588

China - Dongguan
Tel: 86-769-8702-9880

China - Guangzhou
Tel: 86-20-8755-8029

China - Hangzhou
Tel: 86-571-8792-8115

China - Hong Kong SAR
Tel: 852-2943-5100

China - Nanjing
Tel: 86-25-8473-2460

China - Qingdao
Tel: 86-532-8502-7355

China - Shanghai
Tel: 86-21-3326-8000

China - Shenyang
Tel: 86-24-2334-2829

China - Shenzhen
Tel: 86-755-8864-2200

China - Suzhou
Tel: 86-186-6233-1526

China - Wuhan
Tel: 86-27-5980-5300

China - Xian
Tel: 86-29-8833-7252

China - Xiamen
Tel: 86-592-2388138

China - Zhuhai
Tel: 86-756-3210040

ASIA/PACIFIC

India - Bangalore
Tel: 91-80-3090-4444

India - New Delhi
Tel: 91-11-4160-8631

India - Pune
Tel: 91-20-4121-0141

Japan - Osaka
Tel: 81-6-6152-7160

Japan - Tokyo
Tel: 81-3-6880-3770

Korea - Daegu
Tel: 82-53-744-4301

Korea - Seoul
Tel: 82-2-554-7200

Malaysia - Kuala Lumpur
Tel: 60-3-7651-7906

Malaysia - Penang
Tel: 60-4-227-8870

Philippines - Manila
Tel: 63-2-634-9065

Singapore
Tel: 65-6334-8870

Taiwan - Hsin Chu
Tel: 886-3-577-8366

Taiwan - Kaohsiung
Tel: 886-7-213-7830

Taiwan - Taipei
Tel: 886-2-2508-8600

Thailand - Bangkok
Tel: 66-2-694-1351

Vietnam - Ho Chi Minh
Tel: 84-28-5448-2100

EUROPE

Austria - Wels
Tel: 43-7242-2244-39
Fax: 43-7242-2244-393

Denmark - Copenhagen
Tel: 45-4485-5910
Fax: 45-4485-2829

Finland - Espoo
Tel: 358-9-4520-820

France - Paris
Tel: 33-1-69-53-63-20
Fax: 33-1-69-30-90-79

Germany - Garching
Tel: 49-8931-9700

Germany - Haan
Tel: 49-2129-3766400

Germany - Heilbronn
Tel: 49-7131-72400

Germany - Karlsruhe
Tel: 49-721-625370

Germany - Munich
Tel: 49-89-627-144-0
Fax: 49-89-627-144-44

Germany - Rosenheim
Tel: 49-8031-354-560

Israel - Ra'anana
Tel: 972-9-744-7705

Italy - Milan
Tel: 39-0331-742611
Fax: 39-0331-466781

Italy - Padova
Tel: 39-049-7625286

Netherlands - Drunen
Tel: 31-416-690399
Fax: 31-416-690340

Norway - Trondheim
Tel: 47-7288-4388

Poland - Warsaw
Tel: 48-22-3325737

Romania - Bucharest
Tel: 40-21-407-87-50

Spain - Madrid
Tel: 34-91-708-08-90
Fax: 34-91-708-08-91

Sweden - Gothenberg
Tel: 46-31-704-60-40

Sweden - Stockholm
Tel: 46-8-5090-4654

UK - Wokingham
Tel: 44-118-921-5800
Fax: 44-118-921-5820