

PART NUMBER	REVISION	DESCRIPTION	FEED TYPE
2266140-1	B	FINE CRIMP HEIGHT ADJUST	MECHANICAL
2266140-2	C	FINE CRIMP HEIGHT ADJUST	PNEUMATIC
7-2266140-1	B	MECHANICAL AND CRIMP TOOLING KIT	MECHANICAL
7-2266140-2	C	PNEUMATIC AND CRIMP TOOLING KIT	PNEUMATIC
7-2266140-7	A	CRIMP TOOLING KIT	-

SUPERSEDED BY 2151956  
 SUPERSEDED BY 2151956  
 SUPERSEDED BY 2151956  
 SUPERSEDED BY 2151956

ATLANTIC VERSION TERMINATOR  
 INTERFACE ADAPTER

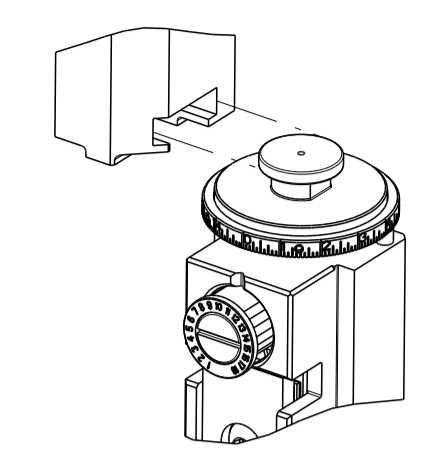

APPLICATOR DATA		
CRIMP	SIZE	TYPE
WIRE	1.98 mm [.078]	F
INSUL	3.68 mm [.145]	O

APPLICATOR INSTRUCTIONS  
 408-34042

TERMINAL DATA: SUMITOMO TERMINAL SUMITOMO CRIMP SPECIFICATION			
TERMINAL NAME: MTO90 SEALED TERMINAL FEMALE			
WIRE STRIP LENGTH		INSULATION DIAMETER RANGE	
4.10-4.90 mm [.161-.193 IN.]		∅	7
TERMINAL APPLICATION SPECIFICATION	SUMITOMO SPECIFICATION	-	-
TERMINALS APPLIED	5	-	-
TE TERMINAL	SUMITOMO TERMINAL	TE SEAL	SUMITOMO SEAL
1572692-1	1500-0110	1949371-1	7160-8234

WIRE SIZE	CRIMP HEIGHT mm [INCH]	CRIMP HEIGHT REFERENCE SETTING
1.25mm2	1.30+/-0.05 [.051+/-0.002]	5.1
0.85mm2	1.20+/-0.05 [.047+/-0.002]	6.1
0.75mm2	1.20+/-0.05 [.047+/-0.002]	6.2
0.50mm2	1.10+/-0.05 [.043+/-0.002]	7.5
0.30mm2	0.95+/-0.05 [.037+/-0.002]	9.2

- 1 RECOMMENDED SPARE PARTS
- 2 REFER TO SUPPLIED INSTRUCTION SHEET FOR CLEANING, LUBRICATION AND STORAGE OF APPLICATOR.
- 3 APPLY PART NUMBER 2-23419-6 LOCTITE TO THREADS OF ITEM 242.
- 4 CRIMP HEIGHT REFERENCE SETTING WAS THE SETTING USED WHEN THE APPLICATOR WAS QUALIFIED AT THE FACTORY. ADJUSTMENT MAY BE NECESSARY WHEN RUNNING APPLICATOR IN THE FIELD.
- 5 THIS APPLICATOR APPLIES TERMINAL WITH A SEAL.
- 6 APPLY TORO-SEAL IN ALLEN SOCKET TO FILL HOLE AFTER FLAT HD HAS BEEN ADJUSTED TO CORRECT HEIGHT AT QUALIFICATION. APPLY #1-23419-5 LOC-TITE TO THREADS.
- 7 THE INSULATION RANGE OF THE SEAL IS ∅2.0- 2.7 mm [.079 -.106 IN.]
- 8. UNLESS SPECIFIED OTHERWISE TORQUE VALUES SHALL BE USED PER DOCUMENT, 101-35000.

**\*WARNING**  
 ON INSTALLATION, SET WIRE DISC TO CRIMP HEIGHT REFERENCE SETTING FOR LARGEST WIRE SIZE. CRIMP HEIGHT REFERENCE SETTINGS GREATER THAN THE VALUE SHOWN MAY CAUSE DAMAGE TO THE CRIMP TOOLING, REFER TO THE INSTRUCTION SHEET FOR PROPER SETUP AND ADJUSTMENTS.

LOC	DIST	REVISIONS					
A	66	P	LTN	DESCRIPTION	DATE	OWN	APVD
		A		RELEASED	12DEC2013	RK	GB
		B		ECR-18-016375	15OCT2018	MS	TE
		C		ECR-21-118290	22OCT2021	FJ	RK
		C1		ECR-23-166970	20FEB2023	JWC	TE

-	1	-	1	-	2119641-1	FEED CAM, AIR FEED	248	
-	1	1	1	1	2119082-8	CAM, SNAIL, INSULATION ADJUSTMENT	244	
-	1	1	1	1	2079764-1	WASHER, WAVE SPRING, CREST-TO-CREST	243	
3	-	1	1	1	2119083-1	RETAINER, INSULATION DIAL	242	
-	1	1	1	1	7-18023-7	SCR, SKT HD CAP M3 X 4.0	241	
-	-	1	-	-	2119580-1	MECHANICAL FEED ASSEMBLY	239	
-	1	-	1	-	2844940-1	AIR FEED MODULE	238	
-	REF	REF	REF	REF	994970-2	COUNTER, MAGNETIC	164	
-	1	1	1	1	1-18028-2	WASHER, FLAT, REG M4	119	
-	1	1	1	1	2844908-1	SCREW, LOCKING	99	
-	1	1	1	1	2844907-1	POST, LOCKING	98	
-	1	1	1	1	455888-5	SPACER, CRIMPER	82	
-	1	1	1	1	1803607-3	DOCUMENTATION PACKAGE	71	
-	1	1	1	1	2119740-1	TAG, IDENTIFICATION	67	
-	2	2	2	2	2168078-1	SCREW, DRIVE, RH, RoHS, 2 x .188	66	
-	1	1	1	1	2168083-2	SCR, SKT HD CAP, RoHS, M4 X 8.0	60	
-	1	1	1	1	5-18022-5	SCR, HEX HD CAP, M4 X 6.0	59	
6	-	1	1	1	985575-3	SCR, FLT SKT HD CAP M3 X 10.0	57	
-	1	1	1	1	1338685-1	PAWL, FEED	56	
-	4	4	4	4	2168083-3	SCR, SKT HD CAP, RoHS, M4 X 12.0	54	
-	2	2	2	2	1-2168083-0	SCR, SKT HD CAP, RoHS, M4 X 10	53	
-	1	1	1	1	5018030-1	NUT, HEX, REG, RoHS, M3	52	
-	1	1	1	1	811242-5	BUMPER, HOLD DOWN	51	
-	1	1	1	1	690753-2	SPACER, TONKER	50	
-	1	2	1	2	18023-9	SCR, SKT HD CAP M4 X 6.0	49	
-	-	1	-	-	2119652-1	FEED CAM, PRE FEED	48	
-	-	1	-	-	2119653-1	FEED CAM, POST FEED	47	
-	1	1	1	1	1803583-9	APPLICATOR BASIC ASSEMBLY, SF	46	
-	1	1	1	1	1803515-1	RAM ASSEMBLY, SF ATLANTIC	44	
-	1	1	1	1	1803602-1	SCR, BHSC, RoHS (M8 X 25)	41	
-	1	1	1	1	1752356-3	SUPPORT, TERMINAL	34	
-	2	2	2	2	2079383-5	SCR, BHSC, RoHS (M4 X 20)	33	
-	2	2	2	2	2-2844962-8	SPACER, CYLINDRICAL, STRIP GUIDE	30	
-	1	1	1	1	2844992-1	ASSEMBLY, STRIP GUIDE	29	
-	1	1	1	1	455888-3	SPACER, CRIMPER	28	
-	1	1	1	1	1320928-2	STRIP GUIDE	24	
-	1	1	1	1	2168083-2	SCR, SKT HD CAP, RoHS, M4 X 8.0	21	
-	1	1	1	1	1-18028-2	WASHER, FLAT, REG M4	20	
-	1	1	1	1	2119533-1	STRIPPER, SIDE FEED	19	
1	-	1	-	-	2119806-1	INSERT, SHEAR	13	
-	1	1	1	1	3-22280-3	SPRING, COMPRESSION	12	
-	1	1	1	1	1-356885-4	STOP, SHEAR	11	
1	-	1	-	-	2119805-1	SHEAR HOLDER, FRONT	10	
1	-	1	-	-	318707-1	FLOATING SHEAR, FRONT	9	
1	2	2	1	1	1-1633703-7	ANVIL, COMBINATION	8	
-	-	-	-	-	-	-	7	
-	-	-	-	-	-	-	6	
-	1	1	1	1	2119781-1	DEPRESSOR, SHEAR	5	
-	1	1	1	1	2-238011-2	BLOCK, CRIMPER SPACER	4	
1	2	2	1	1	3-2119784-8	CRIMPER, INSULATION O PREMIUM	3	
-	1	1	1	1	1-455888-6	SPACER, CRIMPER	2	
1	2	2	1	1	3-1633305-0	CRIMPER, WIRE PREMIUM	1	
-	77	-72	-71	-2	-1	PART NO	DESCRIPTION	ITEM NO

ATLANTIC VERSION  
 Shown on sheets 1 of 4 & 2 of 4  
 (Pacific version shown on sheets 3 of 4 & 4 of 4)

DIMENSIONS:		TOLERANCES UNLESS OTHERWISE SPECIFIED:		OWN: X. ZHAO 04NOV2013		TE Connectivity Harrisburg, PA 17105-3608	
mm		0 PLC ±		CHK: T. ELBIN 04NOV2013		NAME: Ocean Side Feed Applicator	
		1 PLC ±		APVD: L. ZHANG 04NOV2013		SIZE: A1	
		2 PLC ±		PRODUCT SPEC		CAGE CODE: 00779	
		3 PLC ±		APPLICATION SPEC		DRAWING NO: 2266140	
		4 PLC ±		WEIGHT		SCALE: 1:2	
		ANGLES		RESTRICTED TO		SHEET 1 OF 4	
		FINISH		Customer Accessible Production Drawing		REV: C1	

LOC	DIST	REVISIONS					
		P	LTN	DESCRIPTION	DATE	DWN	APVD
A	66	-	-	SEE SHEET 1	-	-	-

# FEED TYPE MECHANICAL

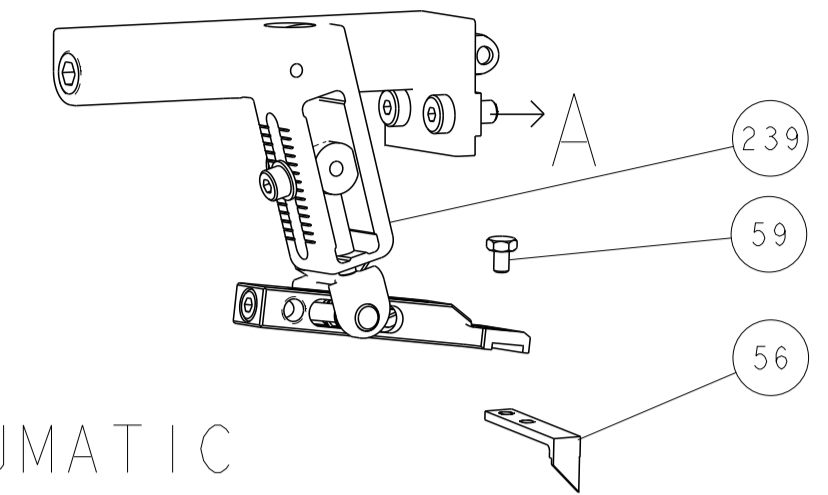

## PNEUMATIC

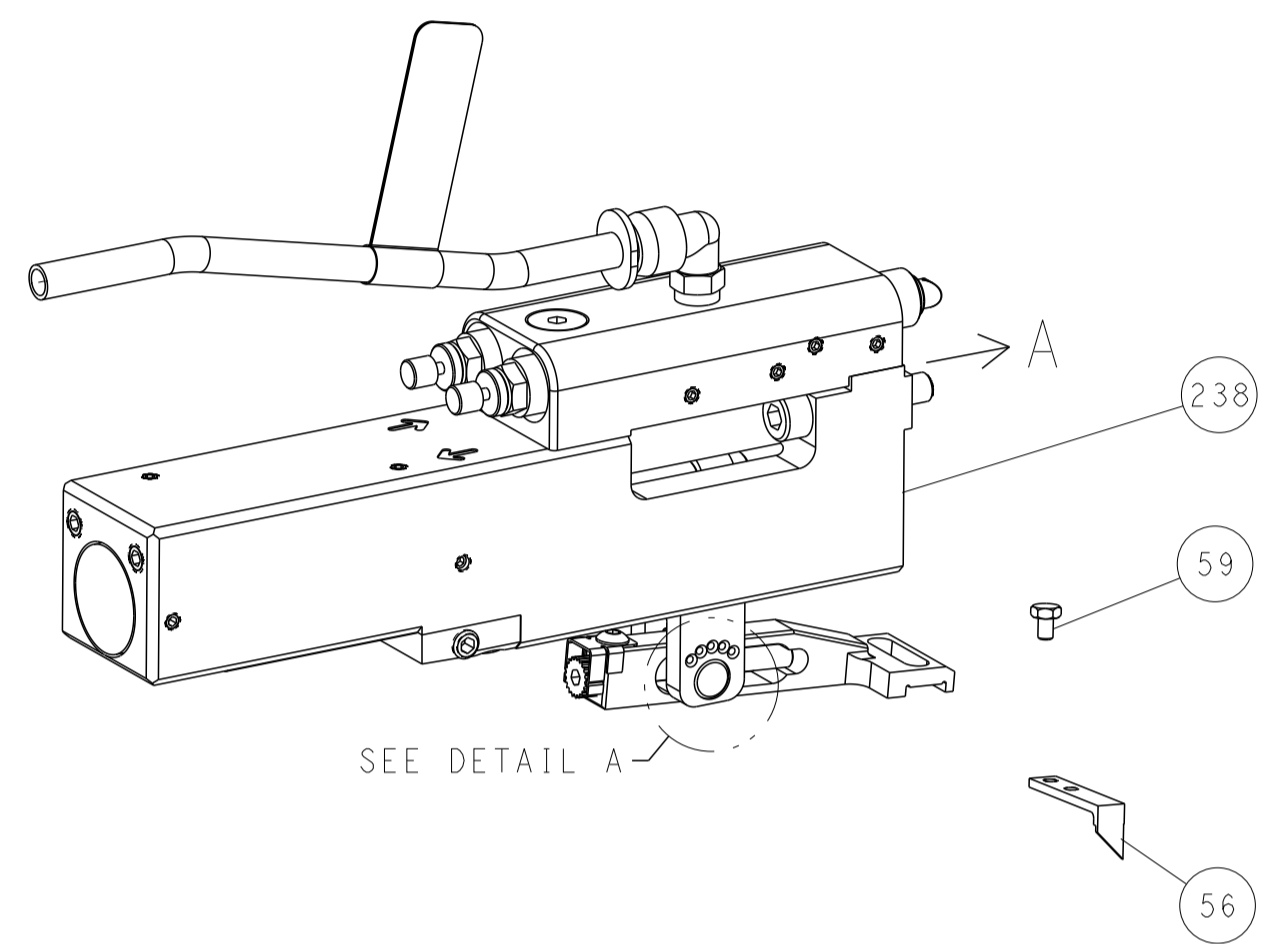

## FEED SPRING SETTING POSITION (SHOWN FROM REAR SIDE)



# CAM POSITIONS

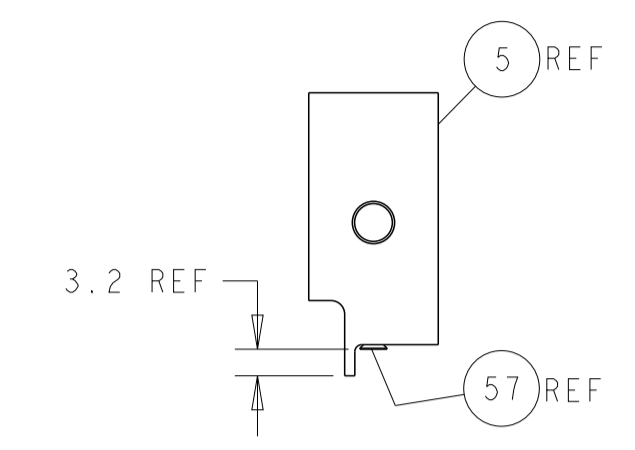
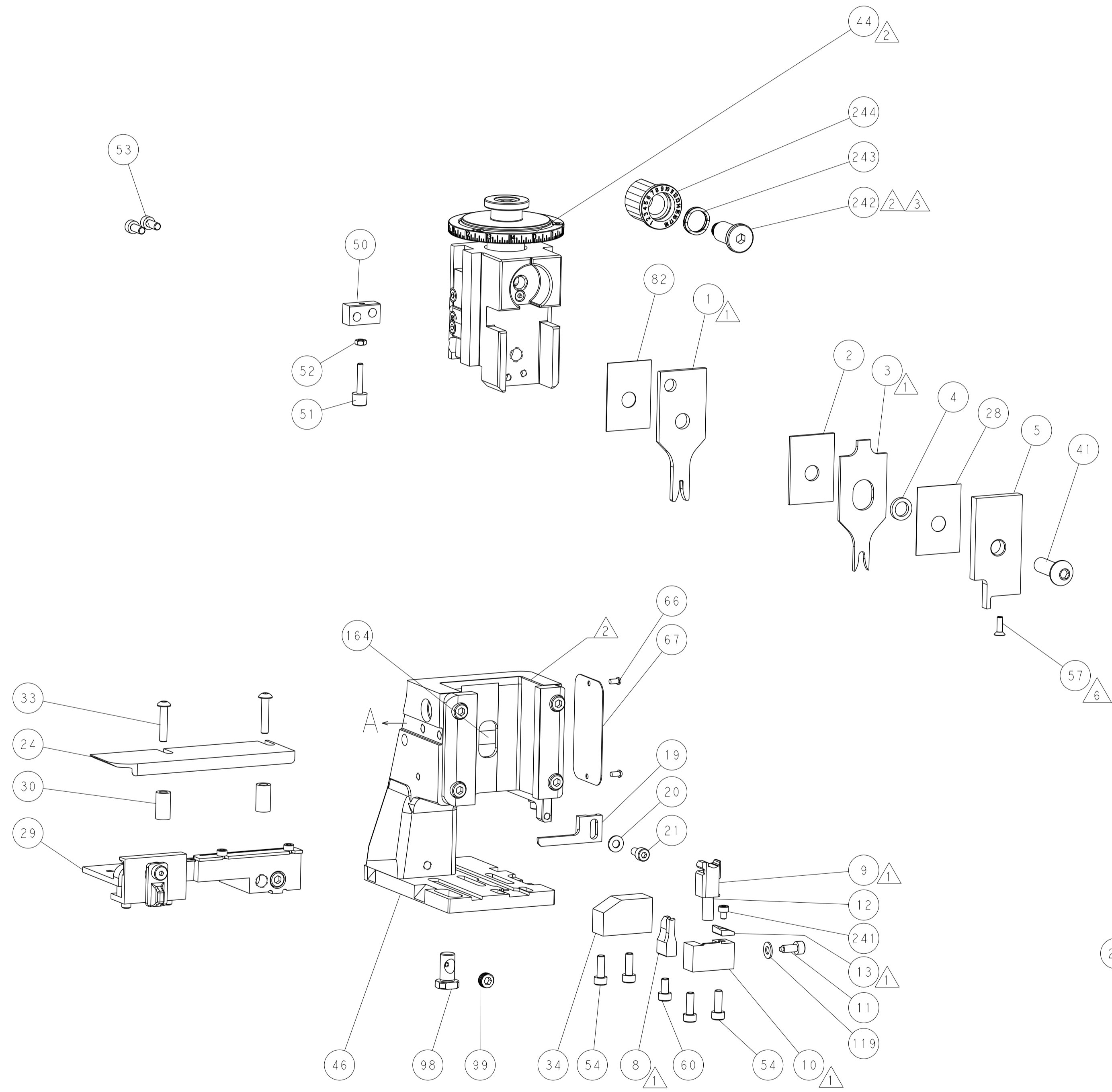
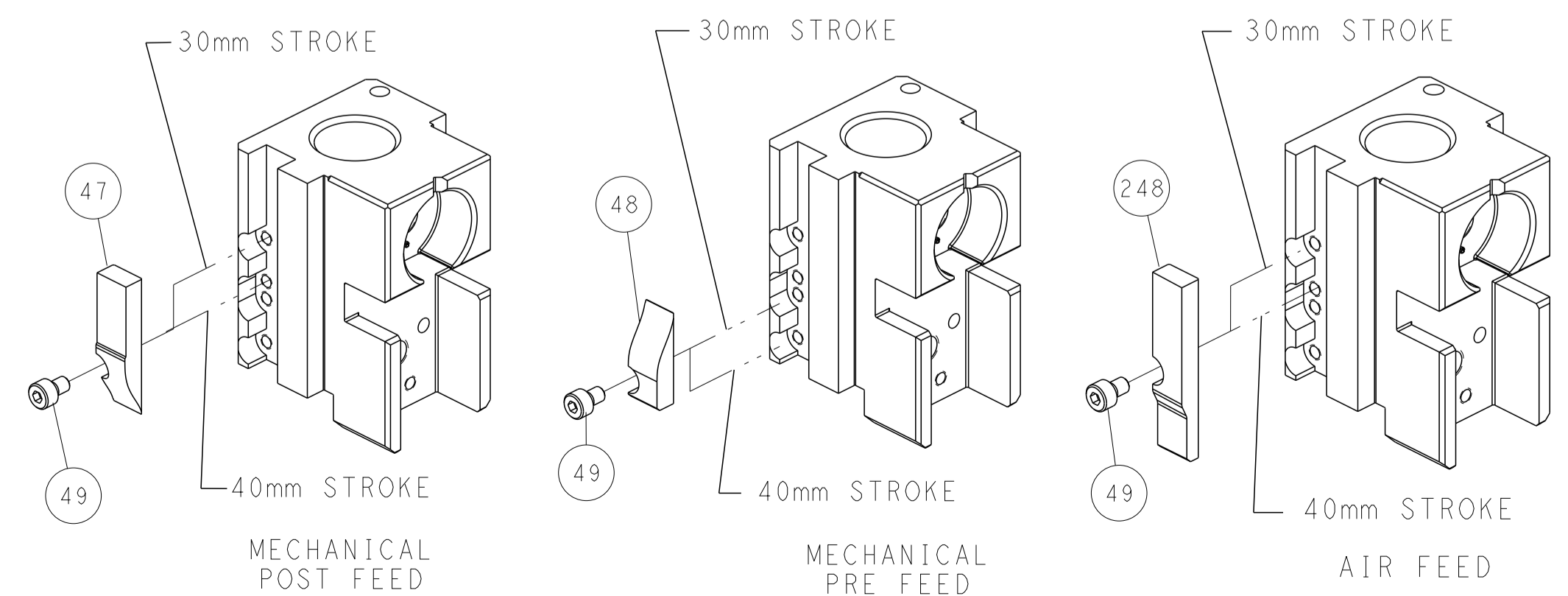

SHEAR DEPRESSOR DETAIL

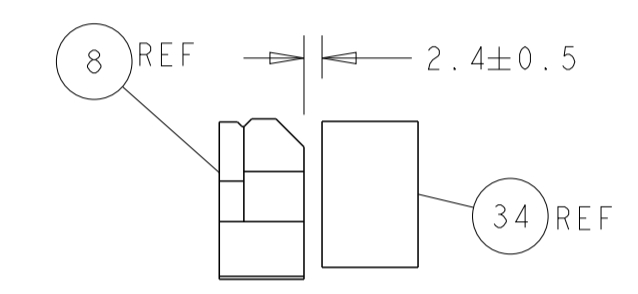

TERMINAL SUPPORT LOCATION

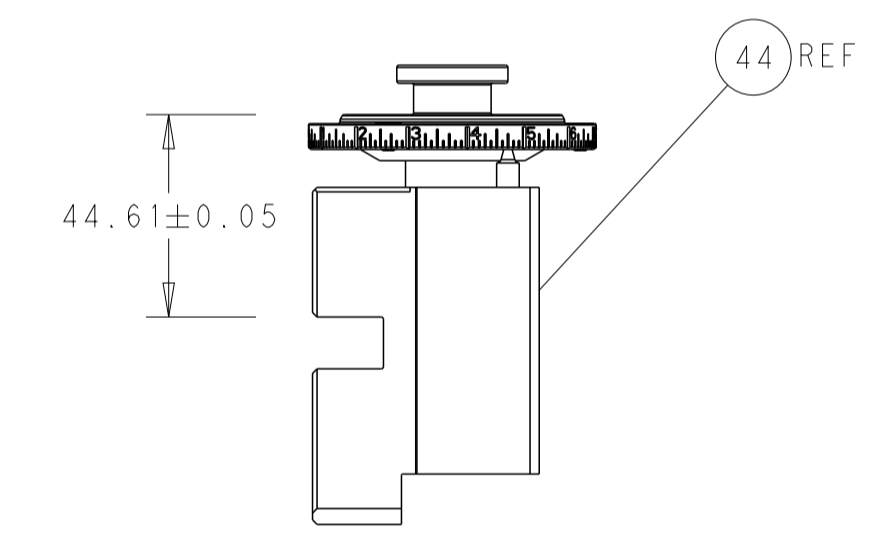

RAM SET-UP

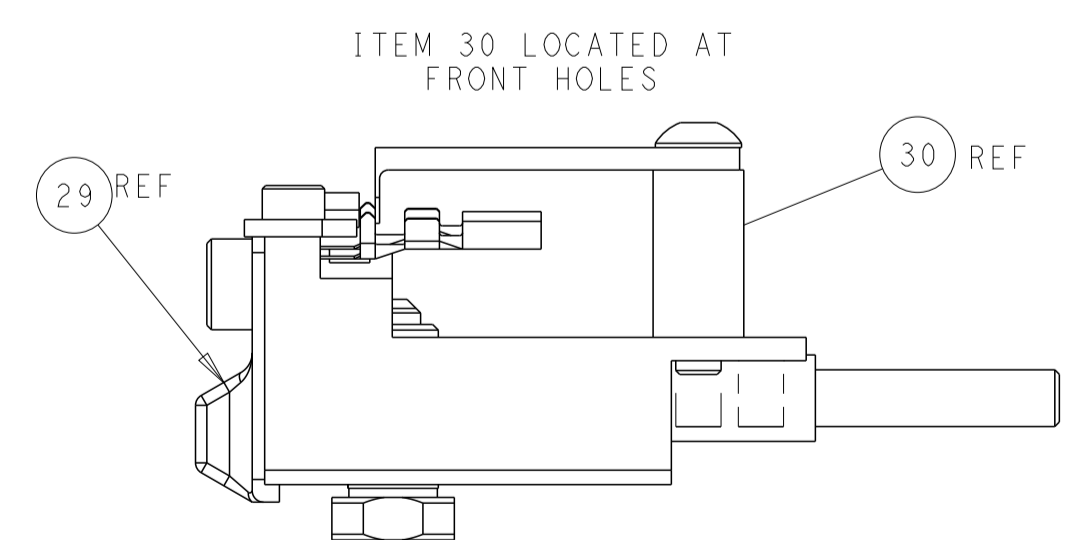

FEED TRACK POSITION GUIDE BY INSULATION BARREL

**ATLANTIC VERSION**  
 Shown on sheets 1 of 4 & 2 of 4  
 (Pacific version shown on sheets 3 of 4 & 4 of 4)

DIMENSIONS: mm 		TOLERANCES UNLESS OTHERWISE SPECIFIED: 0 PLC ±0.5 1 PLC ±0.13 3 PLC ±0.013 4 PLC ±0.001 ANGLES ±0.001		DWN X.ZHAO 04NOV2013 CHK T.ELBIN 04NOV2013 APVD L.ZHANG 04NOV2013		NAME Ocean Side Feed Applicator	
MATERIAL:		FINISH:		WEIGHT:		SIZE: A1 CAGE CODE: 00779 DRAWING NO: C=2266140	
Customer Accessible Production Drawing				SCALE: 1:2		SHEET 2 OF 4 REV C1	

PART NUMBER	REVISION	DESCRIPTION	FEED TYPE
2-2266140-1	B	FINE CRIMP HEIGHT ADJUST	MECHANICAL
2-2266140-2	C	FINE CRIMP HEIGHT ADJUST	PNEUMATIC
7-2266140-7	A	CRIMP TOOLING KIT	-

SUPERSEDED BY 2151956  
 SUPERSEDED BY 2151956

PACIFIC VERSION TERMINATOR  
 INTERFACE ADAPTER

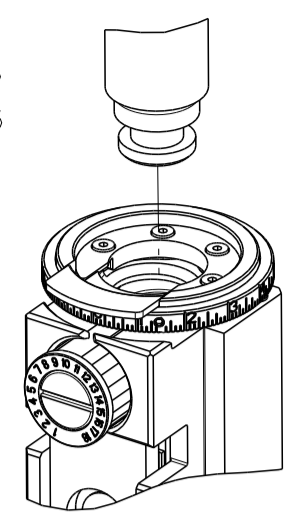

APPLICATOR DATA		
CRIMP	SIZE	TYPE
WIRE	1.98 mm [.078]	F
INSUL	3.68 mm [.145]	O

APPLICATOR INSTRUCTIONS  
 408-34042

TERMINAL DATA: SUMITOMO TERMINASUMITOMO CRIMP SPECIFICATION			
TERMINAL NAME: MTO90 SEALED TERMINAL FEMALE			
WIRE STRIP LENGTH	INSULATION DIAMETER RANGE		
4.10-4.90 mm [1.61-.193 IN]	∅	7	
TERMINAL APPLICATION SPECIFICATION	SUMITOMO SPECIFICATION	-	-
TERMINALS APPLIED 5			
TE TERMINAL	SUMITOMO TERMINAL	TE SEAL	SUMITOMO SEAL
1572692-1	1500-0110	1949371-1	7160-8234

WIRE SIZE	CRIMP HEIGHT mm [INCH]	CRIMP HEIGHT REFERENCE SETTING
1.25mm2	1.30 +/- 0.05 [1.051 +/- .002]	5.1
0.85mm2	1.20 +/- 0.05 [1.047 +/- .002]	6.1
0.75mm2	1.20 +/- 0.05 [1.047 +/- .002]	6.2
0.50mm2	1.10 +/- 0.05 [1.043 +/- .002]	7.5
0.30mm2	0.95 +/- 0.05 [1.037 +/- .002]	9.2

- RECOMMENDED SPARE PARTS
  - REFER TO SUPPLIED INSTRUCTION SHEET FOR CLEANING, LUBRICATION AND STORAGE OF APPLICATOR.
  - APPLY PART NUMBER 2-23419-6 LOCTITE TO THREADS OF ITEM 242.
  - CRIMP HEIGHT REFERENCE SETTING WAS THE SETTING USED WHEN THE APPLICATOR WAS QUALIFIED AT THE FACTORY. ADJUSTMENT MAY BE NECESSARY WHEN RUNNING APPLICATOR IN THE FIELD.
  - THIS APPLICATOR APPLIES TERMINAL WITH A SEAL.
  - APPLY TORQ-SEAL IN ALLEN SOCKET TO FILL HOLE AFTER FLAT HD HAS BEEN ADJUSTED TO CORRECT HEIGHT AT QUALIFICATION. APPLY #1-23419-5 LOC-TITE TO THREADS.
  - THE INSULATION RANGE OF THE SEAL IS ∅2.0- 2.7 mm [1.079 -.106 IN.]
8. UNLESS SPECIFIED OTHERWISE TORQUE VALUES SHALL BE USED PER DOCUMENT, 101-35000.

**\*WARNING**  
 ON INSTALLATION, SET WIRE DISC TO CRIMP HEIGHT REFERENCE SETTING FOR LARGEST WIRE SIZE. CRIMP HEIGHT REFERENCE SETTINGS GREATER THAN THE VALUE SHOWN MAY CAUSE DAMAGE TO THE CRIMP TOOLING, REFER TO THE INSTRUCTION SHEET FOR PROPER SETUP AND ADJUSTMENTS.

LOC	DIST	REVISIONS					
		P	LTN	DESCRIPTION	DATE	OWN	APVD
A	66	-	-	SEE SHEET 1	-	-	-

-	1	1	2119082-8	CAM, SNAIL, INSULATION ADJUSTMENT	244
-	1	1	2079764-1	WASHER, WAVE SPRING, CREST-TO-CREST	243
-	1	1	2119083-1	RETAINER, INSULATION DIAL	242
-	1	1	7-18023-7	SCR, SKT HD CAP M3 X 4.0	241
-	-	1	2119580-1	MECHANICAL FEED ASSEMBLY	239
-	1	-	2844940-1	AIR FEED MODULE	238
-	REF	REF	994970-2	COUNTER, MAGNETIC	164
-	1	-	2119641-2	FEED CAM, AIR FEED	151
-	1	1	2168083-8	SCR, SKT HD CAP, RoHS, M4 X 16	144
-	4	4	2168083-9	SCR, SKT HD CAP, RoHS, M4 X 20	143
-	-	1	2119653-2	FEED CAM, POST FEED	142
-	1	1	1-1803583-0	APPLICATOR BASIC ASSEMBLY, SF	141
-	1	1	1803516-1	RAM ASSEMBLY, SF PACIFIC	140
-	1	1	1-18028-2	WASHER, FLAT, REG M4	119
-	1	1	2844908-1	SCREW, LOCKING	99
-	1	1	2844907-1	POST, LOCKING	98
-	1	1	455888-5	SPACER, CRIMPER	82
-	1	1	1803607-3	DOCUMENTATION PACKAGE	71
-	1	1	2119740-1	TAG, IDENTIFICATION	67
-	2	2	2168078-1	SCREW, DRIVE, RH, RoHS, 2 x .188	66
-	1	1	5-18022-5	SCR, HEX HD CAP, M4 X 6.0	59
-	1	1	985575-3	SCR, FLT SKT HD CAP M3 X 10.0	57
-	1	1	1338685-1	PAWL, FEED	56
-	2	2	1-2168083-0	SCR, SKT HD CAP, RoHS, M4 X 10	53
-	1	1	5018030-1	NUT, HEX, REG, RoHS, M3	52
-	1	1	811242-5	BUMPER, HOLD DOWN	51
-	1	1	690753-2	SPACER, TONKER	50
-	1	2	18023-9	SCR, SKT HD CAP M4 X 6.0	49
-	-	1	2119652-1	FEED CAM, PRE FEED	48
-	1	1	1803602-1	SCR, BHSC, RoHS (M8 X 25)	41
-	1	1	1752356-3	SUPPORT, TERMINAL	34
-	2	2	2079383-5	SCR, BHSC, RoHS (M4 X 20)	33
-	2	2	2-2844962-8	SPACER, CYLINDRICAL, STRIP GUIDE	30
-	1	1	2844992-1	ASSEMBLY, STRIP GUIDE	29
-	1	1	455888-3	SPACER, CRIMPER	28
-	1	1	1320928-2	STRIP GUIDE	24
-	1	1	2168083-2	SCR, SKT HD CAP, RoHS, M4 X 8.0	21
-	1	1	1-18028-2	WASHER, FLAT, REG M4	20
-	1	1	2119533-1	STRIPPER, SIDE FEED	19
-	1	1	2119806-1	INSERT, SHEAR	13
-	1	1	3-22280-3	SPRING, COMPRESSION	12
-	1	1	1-356885-4	STOP, SHEAR	11
-	1	1	2119805-1	SHEAR HOLDER, FRONT	10
-	1	1	318707-1	FLOATING SHEAR, FRONT	9
-	1	1	1-1633703-7	ANVIL, COMBINATION	8
-	-	-	-	-	7
-	-	-	-	-	6
-	1	1	2119781-1	DEPRESSOR, SHEAR	5
-	1	1	2-238011-2	BLOCK, CRIMPER SPACER	4
-	1	1	3-2119784-8	CRIMPER, INSULATION O PREMIUM	3
-	1	1	1-455888-6	SPACER, CRIMPER	2
-	1	1	3-1633305-0	CRIMPER, WIRE PREMIUM	1

PACIFIC VERSION  
 Shown on sheets 3 of 4 & 4 of 4  
 (Atlantic version shown on sheets 1 of 4 & 2 of 4)

DIMENSIONS:		TOLERANCES UNLESS OTHERWISE SPECIFIED:		DWG: X.ZHAO 04NOV2013		REV: 1	
mm		0 PLC ±		CHK: T.ELBIN 04NOV2013		NAME: TE Connectivity	
1 PLC ±		1 PLC ±		APVD: L.ZHANG 04NOV2013		Harrisburg, PA 17105-3608	
2 PLC ±		2 PLC ±		PRODUCT SPEC		Ocean Side Feed	
3 PLC ±		3 PLC ±		APPLICATION SPEC		Applicator	
4 PLC ±		4 PLC ±		SIZE: A1		CAGE CODE: 00779	
ANGLES		FINISH		DRAWING NO: 2266140		RESTRICTED TO:	
MATERIAL		WEIGHT		SCALE: 1:2		SHEET 3 OF 4	
				Customer Accessible Production Drawing		REV: C1	

LOC	DIST	REVISIONS					
A	66	P	LTN	DESCRIPTION	DATE	DWN	APVD
-	-	-	-	SEE SHEET 1	-	-	-

# FEED TYPE MECHANICAL

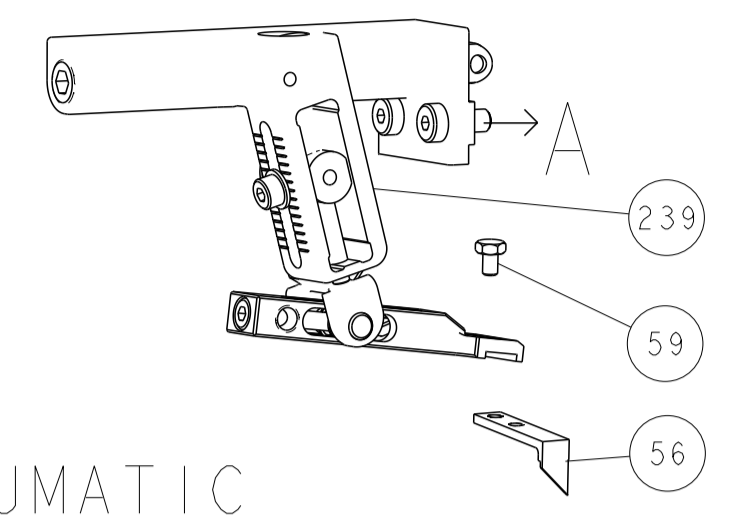

## PNEUMATIC

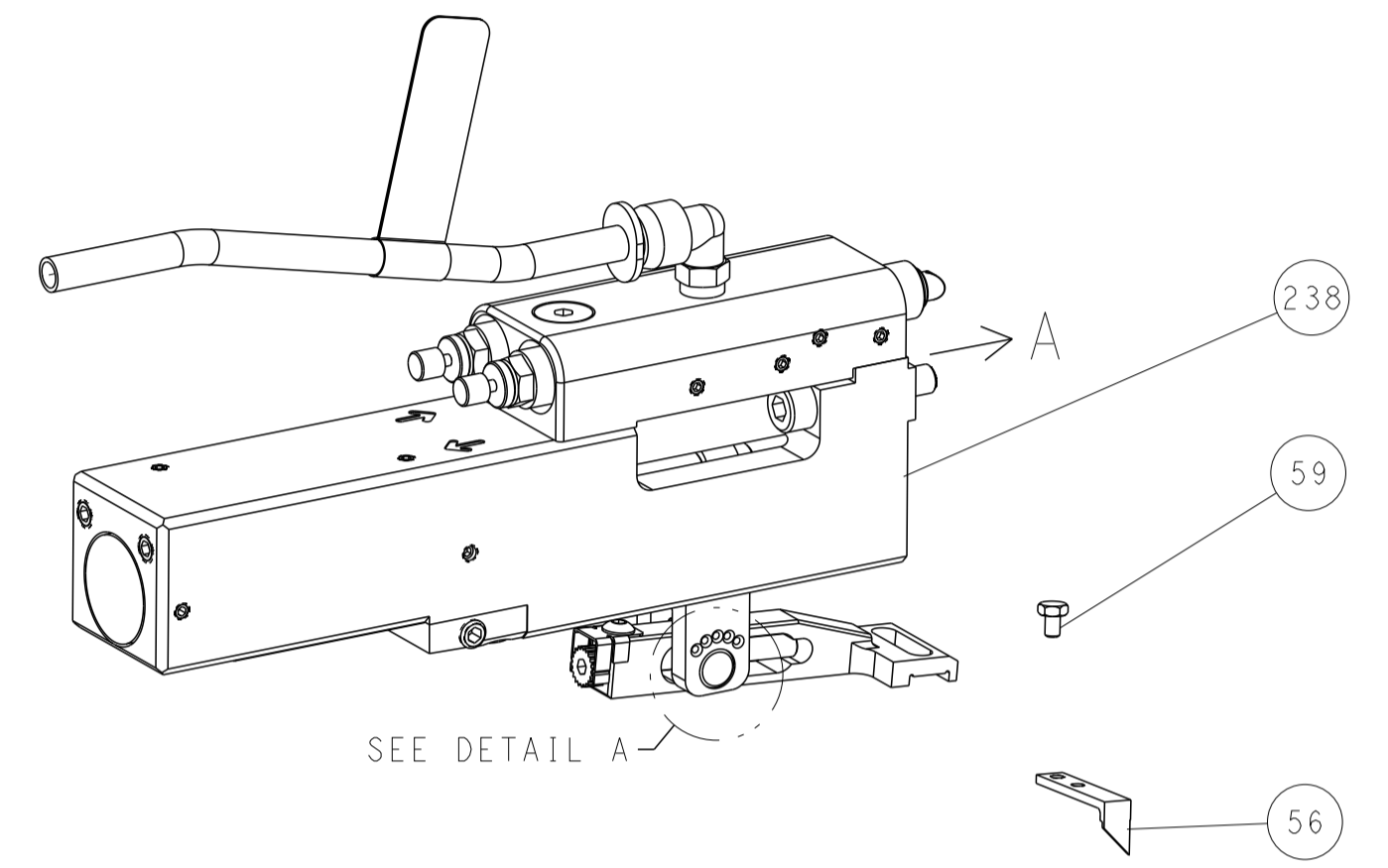

### FEED SPRING SETTING POSITION (SHOWN FROM REAR SIDE)

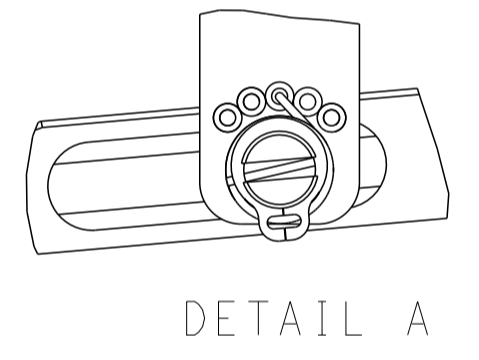

DETAIL A

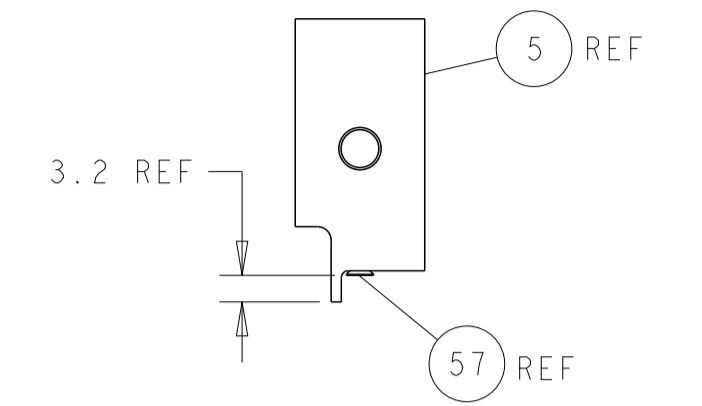
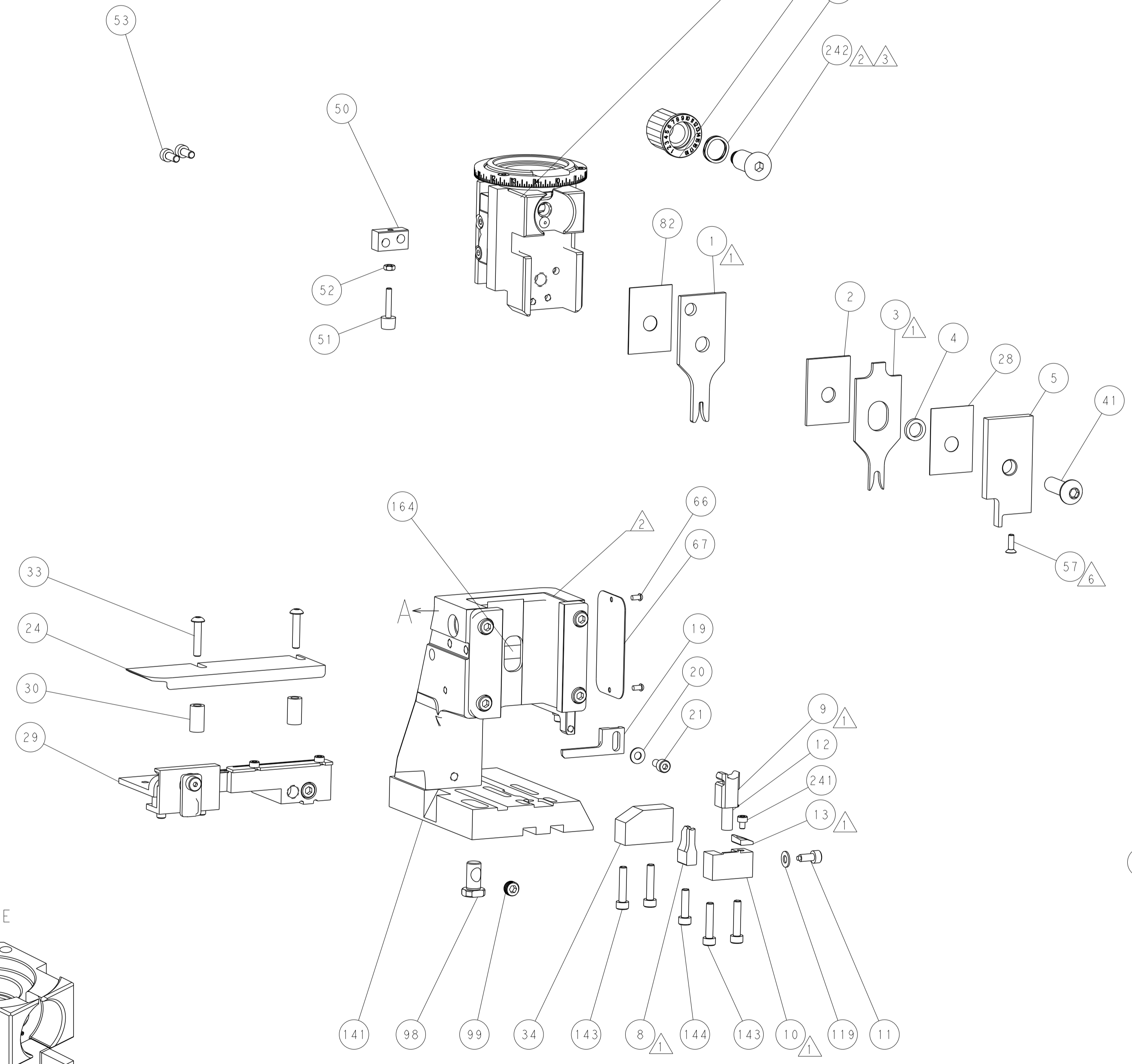

SHEAR DEPRESSOR DETAIL

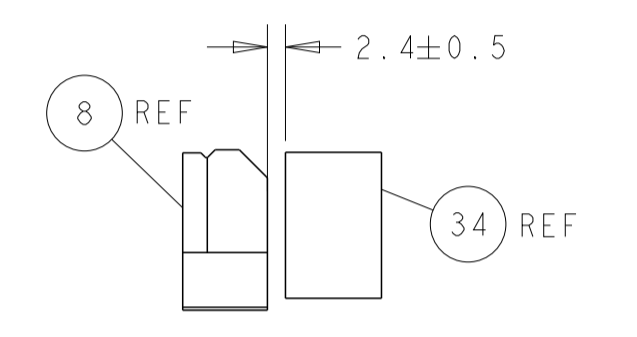

TERMINAL SUPPORT LOCATION

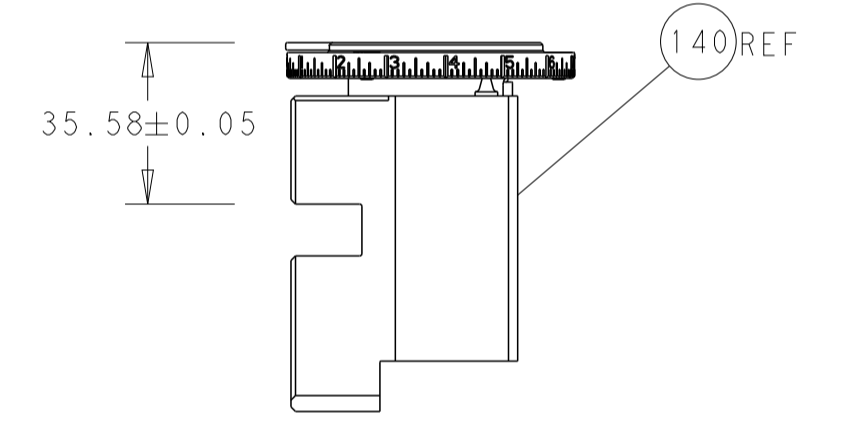

RAM SET-UP

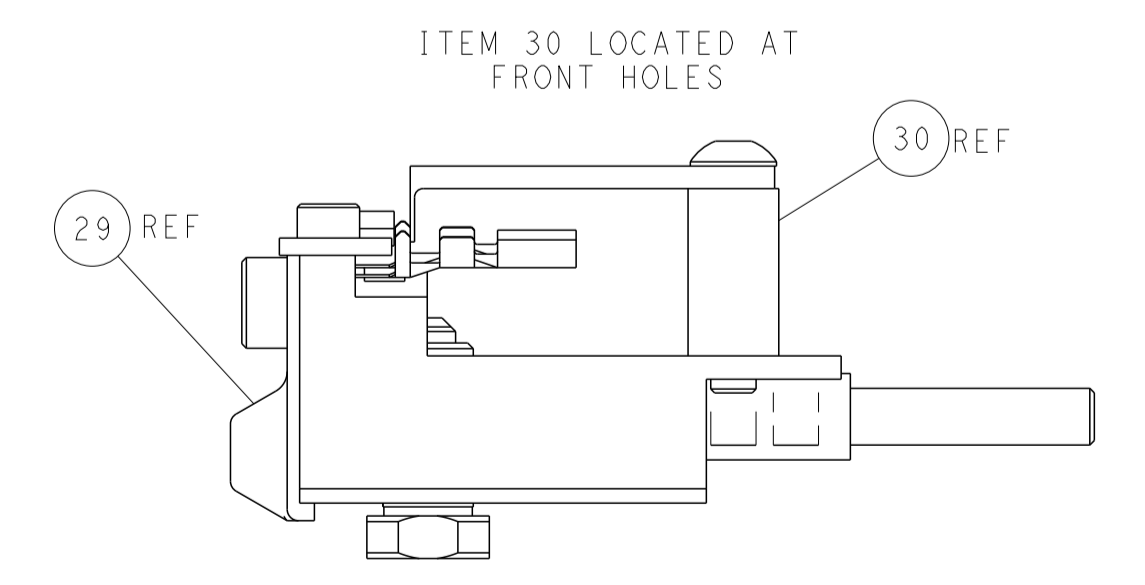

FEED TRACK POSITION GUIDE BY INSULATION BARREL

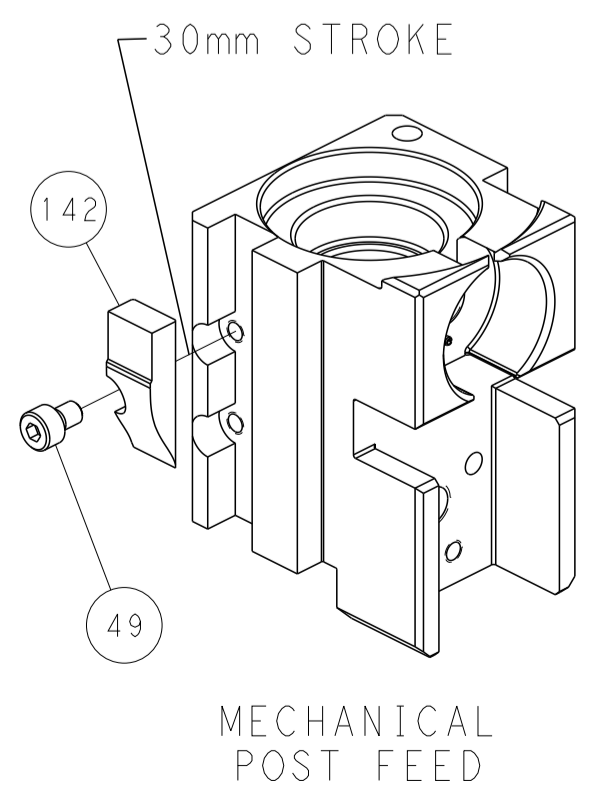

MECHANICAL POST FEED

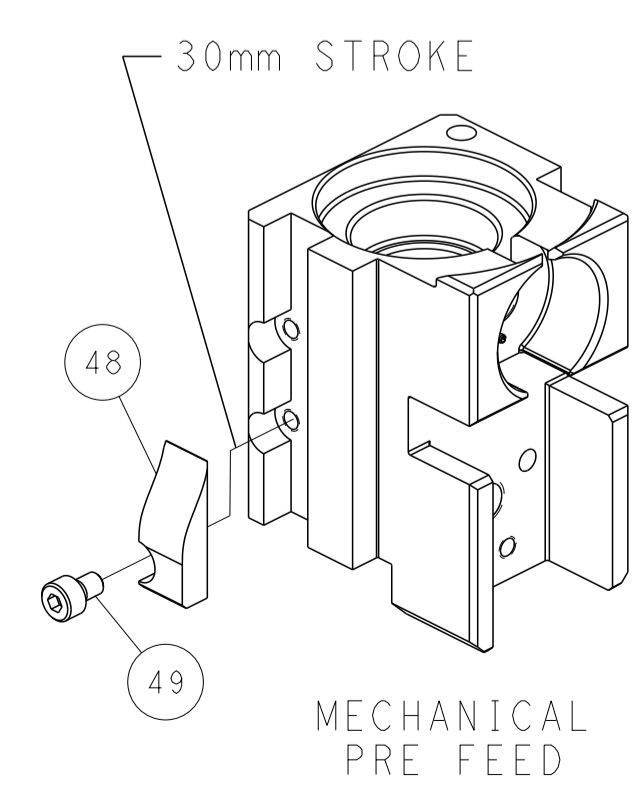

MECHANICAL PRE FEED

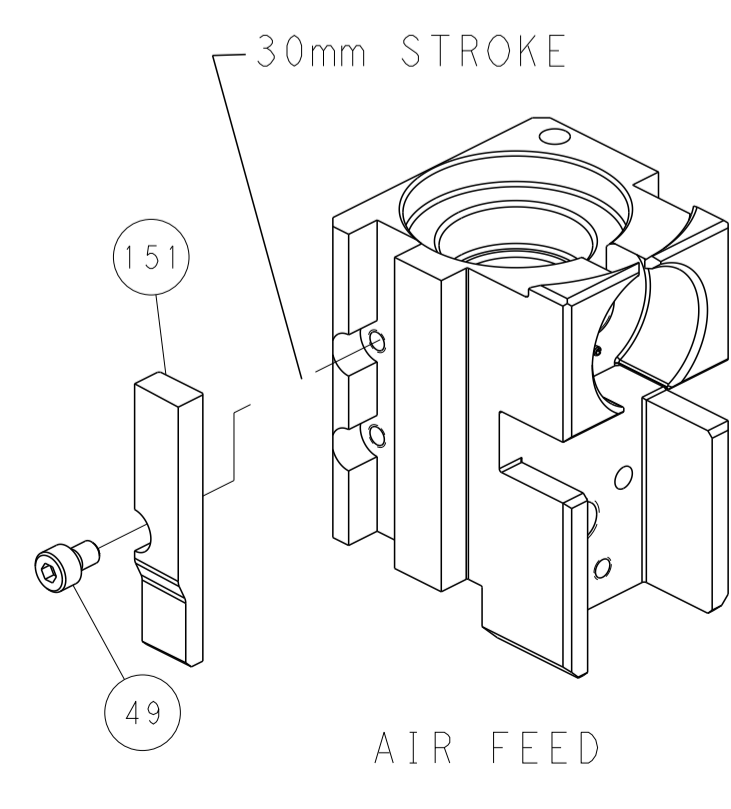

AIR FEED

**PACIFIC VERSION**  
 Shown on sheets 3 of 4 & 4 of 4  
 (Atlantic version shown on sheets 1 of 4 & 2 of 4)

DIMENSIONS: mm 		TOLERANCES UNLESS OTHERWISE SPECIFIED: 0 PLC ±.5 1 PLC ±0.5 2 PLC ±0.13 3 PLC ±0.013 4 PLC ±0.001 ANGLES FINISH ±.		DWN X_ZHAO 04NOV2013 CHK T_ELBIN 04NOV2013 APVD L_ZHANG 04NOV2013 PRODUCT SPEC APPLICATION SPEC WEIGHT Customer Accessible Production Drawing		NAME Ocean Side Feed Applicator SIZE CAGE CODE DRAWING NO A1 00779 C=2266140 SCALE 1:2 SHEET 4 OF 4 REV C1		RESTRICTED TO - - -	
--------------------	--	--	--	---	--	--	--	------------------------------	--