

## DESCRIPTION

The EV3391EF-00A is an evaluation board for the MP3391EF, a step-up converter designed for large liquid-crystal displays that employ an array of LEDs as the light source. It can drive up to 8 WLED strings in parallel with 80mA maximum current.

The MP3391 uses external power MOSFET and internal current mode, fixed frequency architecture and includes current ballast in each string terminal, which achieves 2.5% current regulation accuracy between strings. Low feedback voltage at each LED string help reduce power loss and improve efficiency.

The MP3391 is flexible for extending LED channels with two or more MP3391s in parallel.

The MP3391 has multiple features to protect the converter from fault conditions, including under-voltage lockout, current limiting, over voltage, short LED, open LED and thermal shut-down protection.

## ELECTRICAL SPECIFICATIONS

Parameter	Symbol	Value	Units
Input Voltage	$V_{IN}$	10 – 28	V
LEDs #		8 strings parallel and 12 LEDs/string	
LED Current	$I_{LED}$	60/string	mA

## FEATURES

- 10V to 28V Input Voltage Range
- External Power MOSFET
- Up to 90% Efficiency
- Programmable Over Voltage Protection
- Drives up to 8 Strings Parallel 2.5% Current Regulation Accuracy Between Strings
- Programmable Switching Frequency:
- PWM or DC Input Burst PWM Dimming
- Open and Short LED Load Protection
- Thermal Shutdown
- Flexible Extended Channels Applications

## APPLICATIONS

- Notebook PC
- LCD Monitor
- LCD TV
- Handy Terminals Display
- Automotive Systems and Tablet Computer

All MPS parts are lead-free and adhere to the RoHS directive. For MPS green status, please visit MPS website under Quality Assurance. "MPS" and "The Future of Analog IC Technology" are Registered Trademarks of Monolithic Power Systems, Inc.

**EV3391EF-00A EVALUATION BOARD**

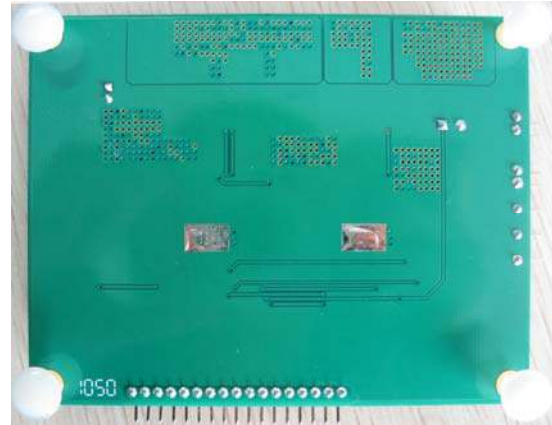

(L x W x H) 9.8cm x 7.65cm x 1cm

Board Number	MPS IC Number
EV3391EF-00A	MP3391EF

# EVALUATION BOARD SCHEMATIC

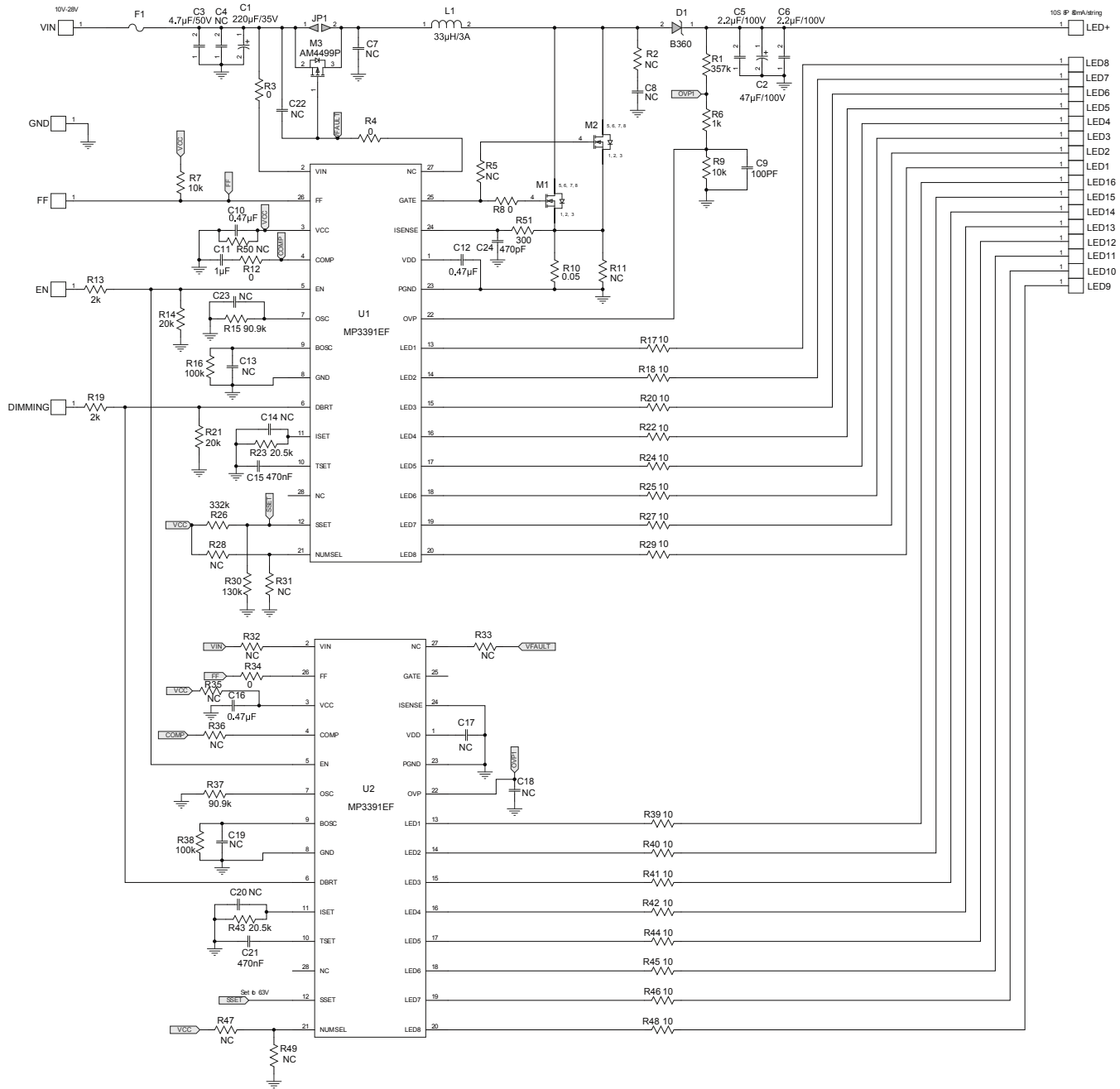

**EV3391EF-00A BILL OF MATERIALS**

Qty	Ref	Value	Description	Package	Manufacturer	Part Number
1	C1	220 $\mu$ F	Electrolytic Capacitor, 35V			
2	C5,C6	2.2 $\mu$ F	Ceramic Capacitor, 100V, X7R	1210	Murata	GRM32ER71H225KA88L
1	C3	4.7 $\mu$ F	Ceramic Capacitor, 50V, X7R	1210	Murata	GRM32ER71H475KA88L
2	C4,C7	NC		1210		
1	C2	47 $\mu$ F	Electrolytic Capacitor, 100V		Jianghai	ECV2AVS470M
9	C8,C13, C14,C17, C18,C19, C20,C22, C23	NC		0603		
1	C9	100pF	Ceramic Capacitor, 50V, COG	0603	Murata	GRM1885C1H101JA01D
6	C10,C12, C15,C16, C21,C24	0.47 $\mu$ F	Ceramic Capacitor, 25V, X7R	0603	Murata	GRM1885C1H474JA01D
1	C11	1 $\mu$ F	Ceramic Capacitor, 16V, X7R	0603	Murata	GRM188R71H105KA93D
1	C16	470nF	Ceramic Capacitor, 10V, X7R	0603	Murata	GRM188R71H474KA93D
1	D1		Diode Schottky, 90V, 3A	SMB	Diodes Inc	B390
1	F1	0 $\Omega$	Fuse, 2A, 63V	1206	Cooper Bussman	3216FF2-R
1	L1	33 $\mu$ H	Inductor, 5A	SMD	Würth	7447709330
1	M3		P- channel MOSFET	SO8		AM4499P
1	M2	NC		SO8		
1	M1		N- channel MOSFET	SO8		AG9977GH
10	R5, R28,R31, R35,R47, R49,R50, R32,R33, R36	NC		0603		
1	R1	357k	Resistor, 1%	0603	Yageo	RC0603FR-07357KL
1	R2	NC		0805		
4	R3, R8 R12, R34	0 $\Omega$	Resistor, 5%	0603	Yageo	
1	R6	1k $\Omega$	Resistor, 1%	0603	Yageo	RC0603FR-071KL
2	R9,R7	10k $\Omega$	Resistor, 1%	0603	Yageo	RC0603FR-0710KL
2	R11,R10	0.1 $\Omega$	Current Resistor, 1%	1206		
2	R13,R19	2k $\Omega$	Resistor, 1%	0603	Yageo	RC0603FR-072KL
2	R14,R21	20k $\Omega$	Resistor, 1%	0603	Yageo	RC0603FR-0720KL

**EV3391EF-00A BILL OF MATERIALS** *(continued)*

Qty	Ref	Value	Description	Package	Manufacturer	Part Number
2	R15,R37	90.9kΩ	Resistor, 1%	0603	Yageo	RC0603FR-0790K9L
2	R16,R38	100kΩ	Resistor, 1%	0603	Yageo	RC0603FR-07100KL
16	R17,R18, R20,R22, R24,R25, R27,R29, R39-42, R44,R45, R46,R48	10Ω	Resistor, 1%	0603	Yageo	RC0603FR-0710L
2	R23,R43	20.5kΩ	Resistor, 1%	0603	Yageo	RC0603FR-0720K5L
1	R26	332kΩ	Resistor, 1%	0603	Yageo	RC0603FR-07332KL
1	R30	130kΩ	Resistor, 1%	0603	Yageo	RC0603FR-07130KL
	R51	300	Resistor, 1%	0603	Yageo	RC0603FR-07300RL
2	U1		LED Driver IC	TSSOP2 8	MPS	MP3391EF R1

**PRINTED CIRCUIT BOARD LAYOUT**

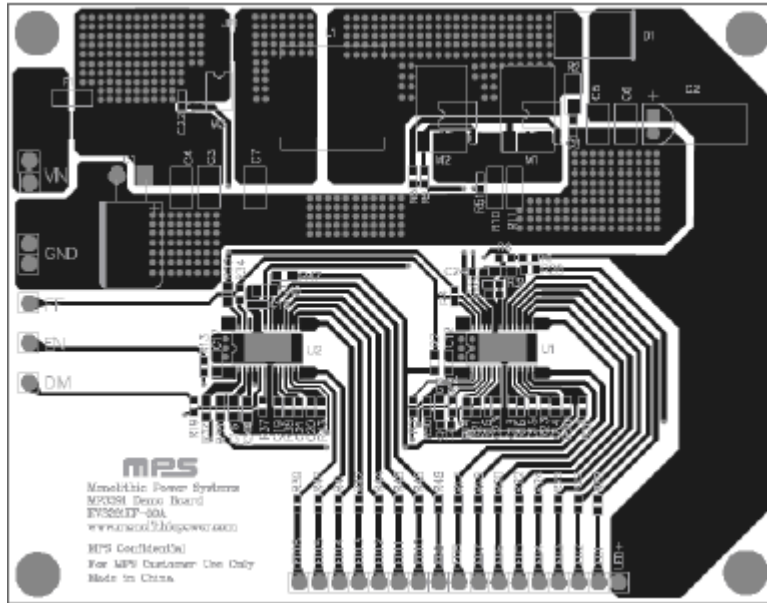

**Figure 1—Top Layer**

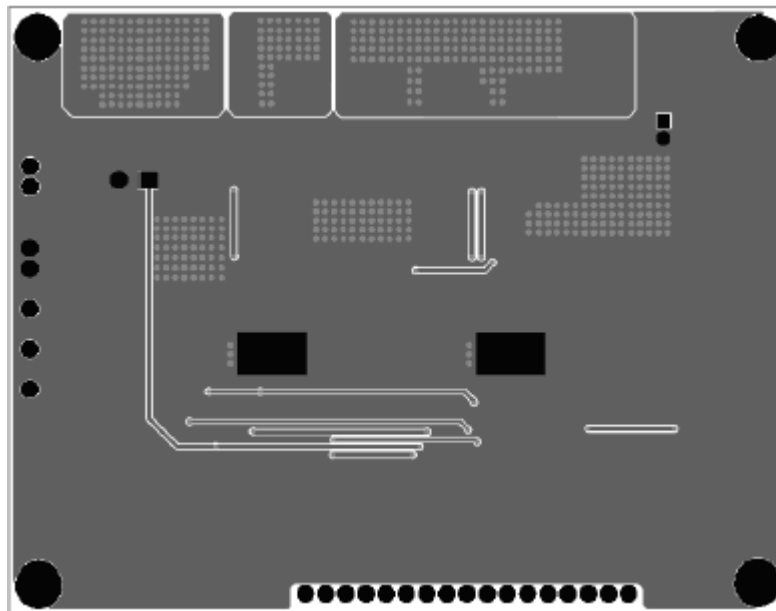

**Figure 2—Bottom Layer**

## QUICK START GUIDE

1. Connect the positive and negative terminals of the load panel (12 white LEDs in series, 8 strings paralleled) to the LED+ and LED1~8 pins on the EV board, respectively.
2. Connect the positive and negative terminals of the power supply (10V ~ 28V) to the VIN and GND pins on the EV board, respectively.
3. Drive EN pin high (5V) to enable the MP3391EF.
4. For PWM dimming, connect a 100k $\Omega$  resistor from BOSC pin to GND and apply a PWM rectangular waveform on DBRT pin. The minimum recommended amplitude of the PWM signal is 1.2V. PWM signal is recommended between 100Hz to 2kHz.
5. If 16 LED strings is required, please add 0 $\Omega$  resistor (0603) on R32, R33 and R36 to make the two ICs work in parallel.

**NOTICE:** The information in this document is subject to change without notice. Users should warrant and guarantee that third party Intellectual Property rights are not infringed upon when integrating MPS products into any application. MPS will not assume any legal responsibility for any said applications.