

REVISIONS					
REV	ECO	DESCRIPTION	DATE	BY	APPR
A4	-	RELEASE NEW DWG FORMAT	10/OCT/13	DRP	-

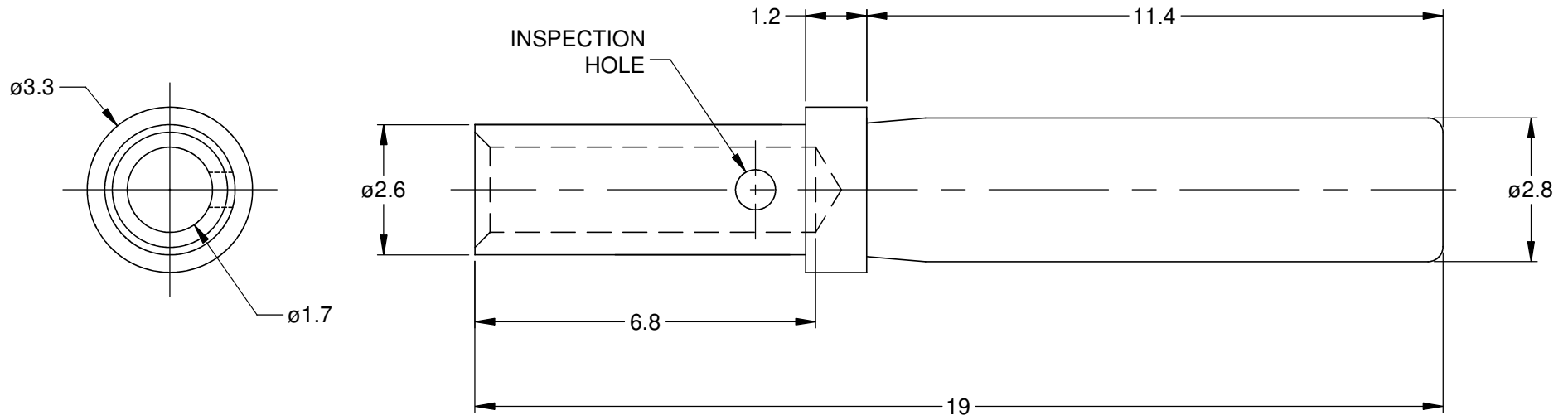

NOTES: UNLESS OTHERWISE SPECIFIED

1. MATERIAL: COPPER ALLOY
2. PLATING: SEE PART NUMBER CHART
3. CONTACT SIZE: 16
4. SPECIFICATIONS:
 - 4.1 CURRENT RATING: 13 AMPS
 - 4.2 CONTACT MILLIVOLT DROP: 60 MILLIVOLT DROP @ 13 AMP TEST CURRENT.
 - 4.3 RoHS COMPLIANT
5. RECOMMENDED WIRE RANGE: 16 - 20 AWG
6. AVAILABLE HAND CRIMPER: CA-5D12
7. ALL DIMENSIONS ARE FOR REFERENCE USE ONLY

PART NUMBER CHART	
PLATING	PART NUMBER
GOLD	AT62-201-1631
NICKEL	AT62-201-16141

SEE PART NUMBER CHART		
PART NUMBER	DESCRIPTION	ITEM

QUANTITY MATERIALS LIST

UNLESS OTHERWISE SPECIFIED 1) All dimensions are in metric(mm). 2) Tolerances are as follows: 1 PL DEC ±0.30 2 PL DEC ±0.15 3 PL DEC ±0.08 Fractions ±1/64 Angles ±1° 3) Note reference =	SIGNATURES	DATE	<h1 style="text-align: center;">Amphenol</h1> <p style="text-align: center;">Sine Systems - www.amphenol-sine.com 44724 Morley Drive Clinton Township, MI 48036</p> <p style="text-align: center;">CONTACT, SOCKET, SOLID, SIZE 16, 16-20 AWG, AT & AHD-9 SERIES</p>		
	DRAWN: D.PARKS	10/OCT/13			
CHECKED:					
ENGINEER:					
MATERIAL SPECIFICATIONS:	APPROVAL:		CONTACT, SOCKET, SOLID, SIZE 16, 16-20 AWG, AT & AHD-9 SERIES		
PROCESS SPECIFICATIONS:	CUSTOMER:				
NEXT ASS'Y:	THIS DRAWING IS SUPPLIED FOR INFORMATION ONLY. DESIGN FEATURES, SPECIFICATIONS AND PERFORMANCE DATA SHOWN HEREON ARE THE PROPERTY OF THE AMPHENOL CORPORATION. NO RIGHTS OF REPRODUCTION ARE IMPLIED. ALL DIMENSIONS ARE SUBJECT TO NORMAL MANUFACTURING VARIATIONS.		SIZE: A TYPE: C- DWG NO: AT62-201-16XXX REVISION: A4		
		SCALE: NONE	SHEET 1 OF 1		