

THIS COPY IS PROVIDED ON A RESTRICTED BASIS AND IS NOT TO BE USED IN ANY WAY DETRIMENTAL TO THE INTERESTS OF PANDUIT CORP.

PANDUIT P/N	WEIGHT
NK2HSF**Y	.54 LB/10 PCS (244 g/10 PCS)

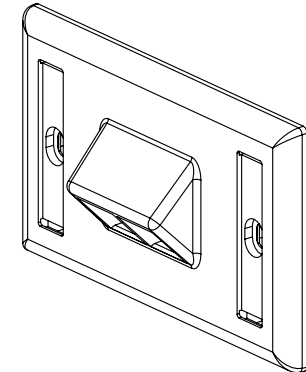
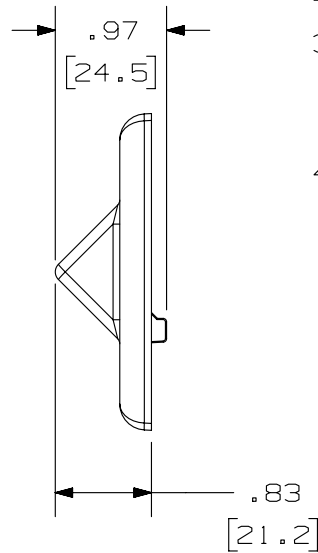
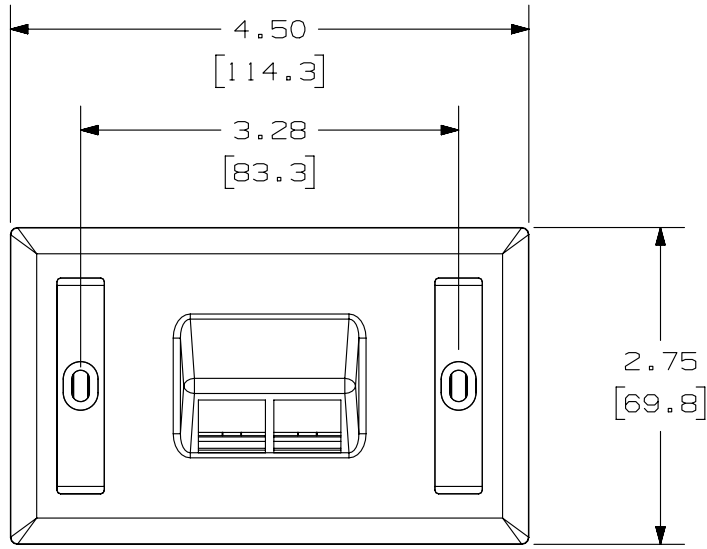

NOTES:

- SEE CURRENT CATALOG FOR ADDITIONAL PART SUFFIXES TO INDICATE COLOR AND OR PACKAGE QUANTITY.
- FACEPLATE WILL ACCEPT TWO NETKEY MODULES.
- PART INCLUDES:
 - FACEPLATE
 - MOUNTING SCREW
 - LABEL
 - LABEL COVER
- DIMENSIONS IN PARENTHESES ARE IN METRIC.

PART NUMBER		NK2HSF**Y	
TITLE			
NETKEY 2 POSITION SINGLE GANG HORIZONTAL SLOPED FACEPLATE WITH LABEL			
CUSTOMER DRAWING			
ITEM REVISION NAME		M02479BJ/06	
DATASET FILE NAME		M02479BJ_DC036/00B	
UNLESS OTHERWISE SPECIFIED, DIMENSIONAL TOLERANCES ARE: IN (mm)		MATERIAL:	
.x ± .xx ± .03 (.8)		.xxx ± .010 (.3)	
ANGLES ±		DRAWING NUMBER:	
THIRD ANGLE PROJECTION		02479-036	
DRAWN BY	DATE	CHK	SCALE
JSP	7-29-06		NONE
SHT 1 OF 1		A	

REV	DATE	BY	CHK	APR	DESCRIPTION	ECN
1	5-08-14	MDJR	REFR	MMR	A. UPDATED TITLE BLOCK.	02479-036
R	7-29-06	JSP			RELEASED TO PRODUCTION	02479-036

D10100DA/14