

LOC		DIST		REVISIONS			
P	LTR	DESCRIPTION	DATE	DN	APVD		
M		REVISED PER ECO-15-016251	13NOV15	KG	CD		

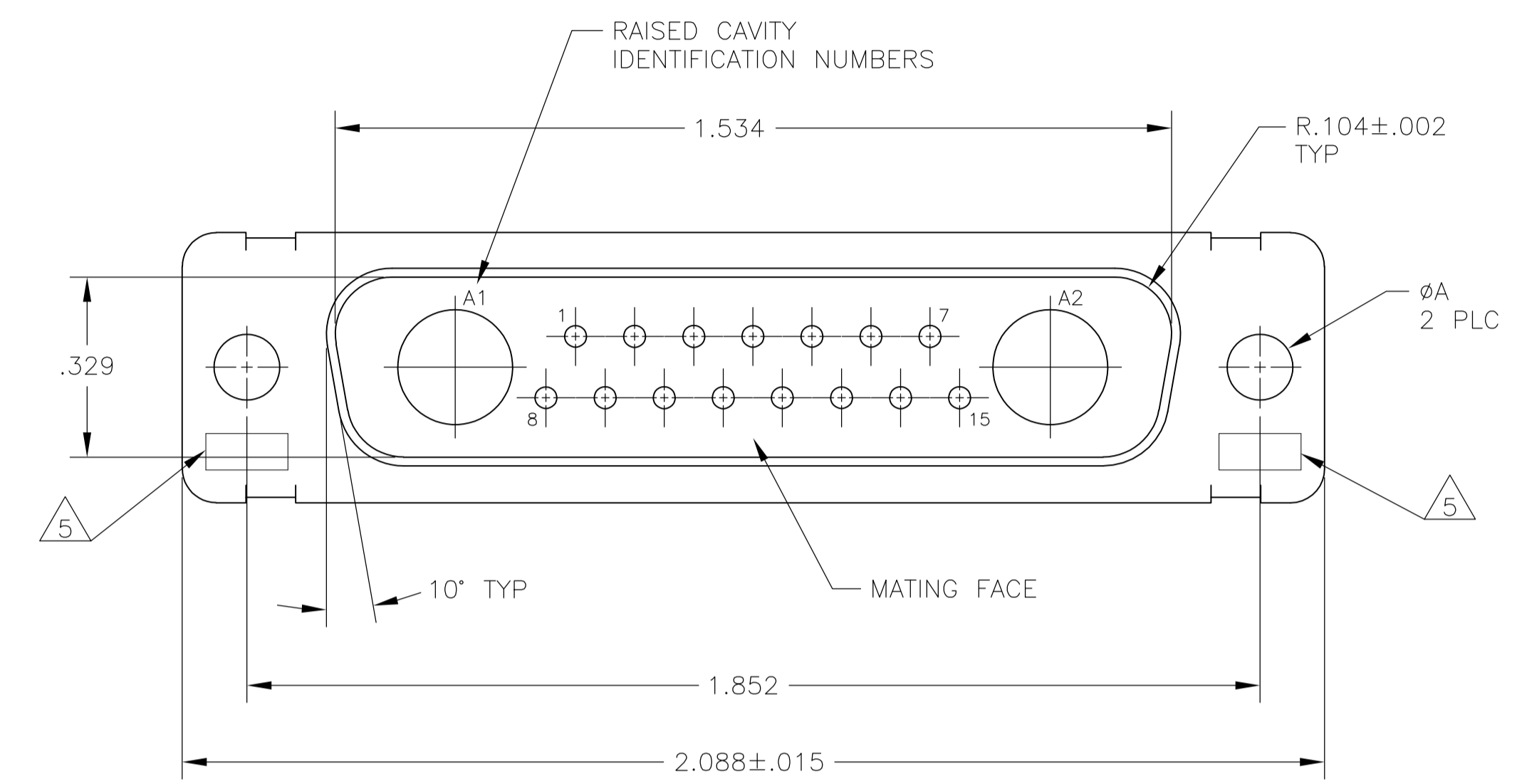

- THIS PLUG WILL MATE WITH ANY 17C2, SIZE 3 RECEPTACLE IN AMPLIMITE SERIES.
- MAXIMUM WIRE INSULATION TO BE USED WITH THIS PLUG IS ϕ .068.
- THIS CONNECTOR ACCEPTS (2) POWER 8, OR COAX PIN CONTACTS IN POSITIONS A1 & A2, PURCHASED SEPARATELY.
- THIS CONNECTOR ACCEPTS SIZE 20 PIN SIGNAL CONTACTS IN POSITIONS 1 THRU 15, PURCHASED SEPARATELY.
- UL/CSA DESIGNATION STAMPED IN THIS AREA, OPTIONAL.
- STEEL PER ASTM-A-109.
- BRASS PER MIL-C-50 AND ASTM-B-36 UNS NO. C26000.
- CADMIUM PLATED PER QQ-P-416.
- GOLD PLATED PER MIL-G-45204 TYPE II, GRADE C, CLASS 1 OVER COPPER PER MIL-C-14550, CLASS IV.
- WESTINGHOUSE PART NO. 97942-645A935H05 INK STAMPED.
- FINISH: TIN PER ASTM-B-545 .000400 MIN THK OVER COPPER PER AMS2418 .000050 MIN THK.
- GROUNDING INDENTS FOR 212506-5 & 5-212506-5 ONLY.
- FINISH: ZINC PLATE PER ASTM-B-633 .000200-.000400 THK WITH SUPPLEMENTARY CHROMATE (Cr3+).

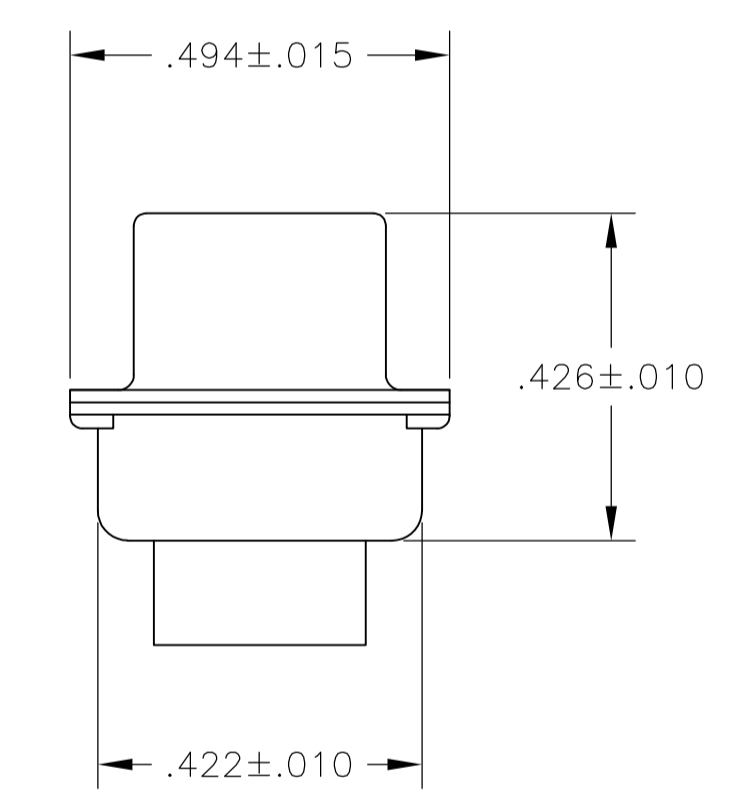
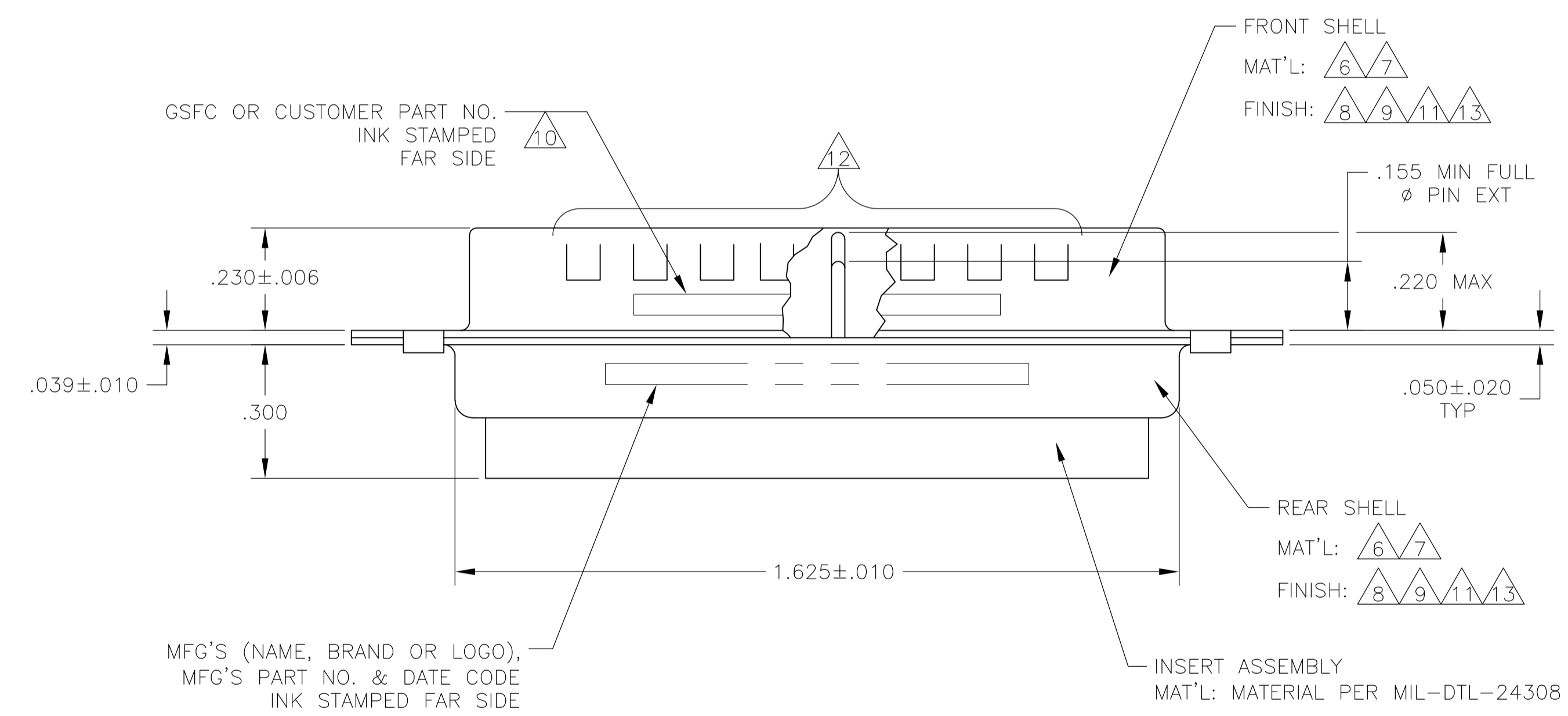

6/13	.120	-	5-212506-1
6/12/11	.120	-	5-212506-5
6/11/12	.120	-	212506-5
7/9	.154	311P405-13S-B-15	212506-4
6/8/10	.120	-	212506-3
7/9	.120	311P405-13S-B-12	212506-2
6/8	.120	-	212506-1
REMARKS	ϕ A	GSFC P/N	PART NO.

THIS DRAWING IS A CONTROLLED DOCUMENT.

MANJUNATH G.M. 27-May-15
 CHARLES THOMAS 27-May-15
 CHARLES THOMAS 27-May-15

STE TE Connectivity

PLUG ASSEMBLY
 AMPLIMITE 17C2
 SIZE 3, SERIES 109, COAX MIX

APPROVALS: DIMENSIONS IN INCHES, TOLERANCES UNLESS OTHERWISE SPECIFIED: 0 PLC ± .005, 1 PLC ± .005, 2 PLC ± .005, 3 PLC ± .005(0.13), 4 PLC ± .005, ANGLES ± 0°30'

MATERIAL: FINISH: WEIGHT: A1 00779C=212506

CUSTOMER DRAWING SCALE 4:1 SHEET 1 OF 1 REV M