

1	
2	
3	
4	
5	
6	
7	
8	
9	
10	
11	
12	
13	
14	
15	
16	
17	
18	

**BASE**

AISI 304 stainless steel, sandblasted matte finish.

**THREADED STEM AND ADJUSTABLE SLEEVE**

AISI 303 stainless steel, sandblasted matte finish, supplied assembled.  
Glued stainless steel assembly screw.

**NO-SLIP DISK**

NBR rubber (PERBUNAN), vulcanised to the base, hardness 80±5 Shore A, black colour.

**FEATURES**

- The convex shape of the base in the stem supporting point reduces the deposit of dirt and simplifies the cleaning operations.
- The adjustable sleeve covers the threading of the stem and it reduces the deposit of dirt.
- The NBR rubber no-slip disk is firmly bonded to the base by means of a vulcanisation process and a glued metal screw. This makes the two parts integral and prevents any solid or liquid substances from infiltrating into the base.

**TECHNICAL DATA**

The load values reported in the table are the result of a series of tests where a vertical load is applied to the stem and distributed on the horizontal plane of the base. If the values are exceeded a deformation of the base can occur first on the metal sheet and therefore also on the no-slip disk plastic material.



Conversion Table 1 mm = 0.039 inch	
D	
mm	inch
60	2.36
80	3.15
100	3.94

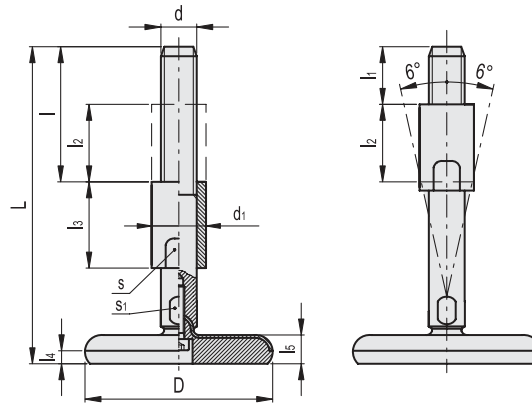

INOX STAINLESS STEEL METRIC

Code	Description	D	d	L	l	l1	l2	l3	l4	l5	d1	s	s1	Max. limit static load [N]	⚖️
409432	LMRS.60-SST-M16x125	60	M16	125	45	13	32	45	4	16	24	20	12	27000	351
409434	LMRS.60-SST-M16x150	60	M16	150	45	13	32	45	4	16	24	20	12	27000	391
409436	LMRS.60-SST-M16x175	60	M16	175	45	13	32	45	4	16	24	20	12	27000	431
409438	LMRS.60-SST-M16x200	60	M16	200	45	13	32	45	4	16	24	20	12	27000	471
409532	LMRS.80-SST-M16x128	80	M16	128	45	13	32	45	5	18	24	20	12	24000	460
409534	LMRS.80-SST-M16x153	80	M16	153	45	13	32	45	5	18	24	20	12	24000	500
409536	LMRS.80-SST-M16x178	80	M16	178	45	13	32	45	5	18	24	20	12	24000	540
409538	LMRS.80-SST-M16x203	80	M16	203	45	13	32	45	5	18	24	20	12	24000	580
409552	LMRS.80-SST-M20x152	80	M20	152	56	16	40	56	5	18	30	24	16	24000	676
409554	LMRS.80-SST-M20x177	80	M20	177	56	16	40	56	5	18	30	24	16	24000	738
409556	LMRS.80-SST-M20x202	80	M20	202	56	16	40	56	5	18	30	24	16	24000	800
409558	LMRS.80-SST-M20x252	80	M20	252	56	16	40	56	5	18	30	24	16	24000	924
409572	LMRS.80-SST-M24x176	80	M24	176	67	19	48	67	5	18	35	30	20	24000	981
409574	LMRS.80-SST-M24x226	80	M24	226	67	19	48	67	5	18	35	30	20	24000	1160
409576	LMRS.80-SST-M24x276	80	M24	276	67	19	48	67	5	18	35	30	20	24000	1339
409632	LMRS.100-SST-M16x130	100	M16	130	45	13	32	45	6	20	24	20	12	21000	591
409634	LMRS.100-SST-M16x155	100	M16	155	45	13	32	45	6	20	24	20	12	21000	631
409636	LMRS.100-SST-M16x180	100	M16	180	45	13	32	45	6	20	24	20	12	21000	671
409638	LMRS.100-SST-M16x205	100	M16	205	45	13	32	45	6	20	24	20	12	21000	711
409652	LMRS.100-SST-M20x155	100	M20	155	56	16	40	56	6	20	30	24	16	21000	807
409654	LMRS.100-SST-M20x180	100	M20	180	56	16	40	56	6	20	30	24	16	21000	869
409656	LMRS.100-SST-M20x205	100	M20	205	56	16	40	56	6	20	30	24	16	21000	931
409658	LMRS.100-SST-M20x255	100	M20	255	56	16	40	56	6	20	30	24	16	21000	1055
409672	LMRS.100-SST-M24x179	100	M24	179	67	19	48	67	6	20	35	30	20	21000	1112
409674	LMRS.100-SST-M24x229	100	M24	229	67	19	48	67	6	20	35	30	20	21000	1231
409676	LMRS.100-SST-M24x279	100	M24	279	67	19	48	67	6	20	35	30	20	21000	1470



Levelling feet and supports