

THIS DRAWING IS UNPUBLISHED. RELEASED FOR PUBLICATION  
 © COPYRIGHT - By - ALL RIGHTS RESERVED.

LOC	DIST	REVISIONS					
CM	00	P	LTR	DESCRIPTION	DATE	DWN	APVD
		J		REVISED PER ECR-20-000824	29MAY2020	PC	SW

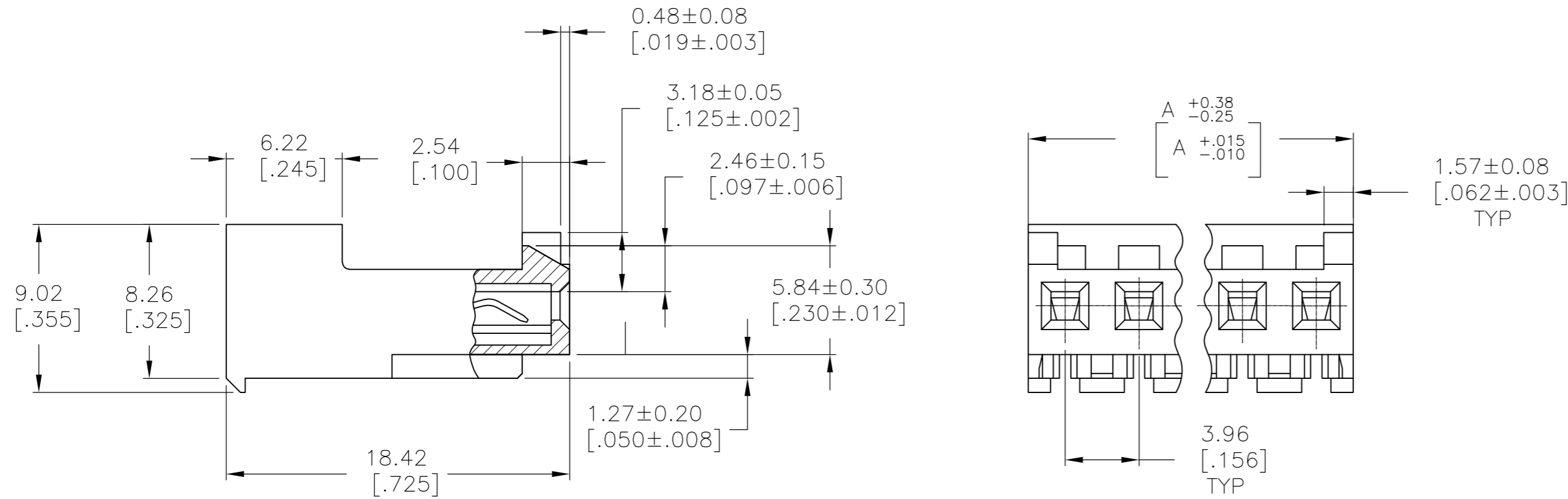
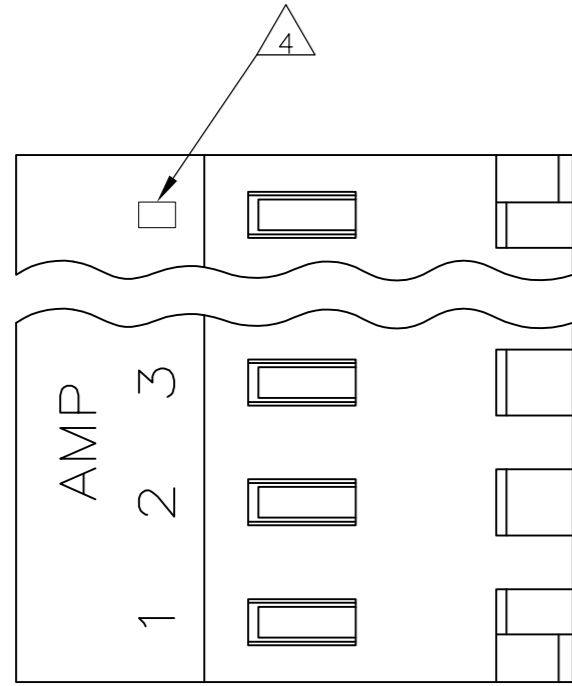

95.10[3.744]	24	5-643820-4
91.13[3.588]	23	5-643820-3
87.17[3.432]	22	5-643820-2
83.21[3.276]	21	5-643820-1
79.25[3.120]	20	5-643820-0
75.29[2.964]	19	4-643820-9
71.32[2.808]	18	4-643820-8
67.36[2.652]	17	4-643820-7
63.40[2.496]	16	4-643820-6
59.44[2.340]	15	4-643820-5
55.47[2.184]	14	4-643820-4
51.51[2.028]	13	4-643820-3
47.55[1.872]	12	4-643820-2
43.59[1.716]	11	4-643820-1
39.62[1.560]	10	4-643820-0
35.66[1.404]	9	3-643820-9
31.70[1.248]	8	3-643820-8
27.74[1.092]	7	3-643820-7
23.77[.936]	6	3-643820-6
19.81[.780]	5	3-643820-5
15.85[.624]	4	3-643820-4
11.89[.468]	3	3-643820-3
7.92[.312]	2	3-643820-2

△	SUPERSEDED BY 5-643820-4	95.10[3.744]	24	2-643820-4
△	SUPERSEDED BY 5-643820-3	91.13[3.588]	23	2-643820-3
△	SUPERSEDED BY 5-643820-2	87.17[3.432]	22	2-643820-2
△	SUPERSEDED BY 5-643820-1	83.21[3.276]	21	2-643820-1
△	SUPERSEDED BY 5-643820-0	79.25[3.120]	20	2-643820-0
△	SUPERSEDED BY 4-643820-9	75.29[2.964]	19	1-643820-9
△	SUPERSEDED BY 4-643820-8	71.32[2.808]	18	1-643820-8
△	SUPERSEDED BY 4-643820-7	67.36[2.652]	17	1-643820-7
△	SUPERSEDED BY 4-643820-6	63.40[2.496]	16	1-643820-6
△	SUPERSEDED BY 4-643820-5	59.44[2.340]	15	1-643820-5
△	SUPERSEDED BY 4-643820-4	55.47[2.184]	14	1-643820-4
△	SUPERSEDED BY 4-643820-3	51.51[2.028]	13	1-643820-3
△	SUPERSEDED BY 4-643820-2	47.55[1.872]	12	1-643820-2
△	SUPERSEDED BY 4-643820-1	43.59[1.716]	11	1-643820-1
	OBSOLETE	39.62[1.560]	10	1-643820-0
△	SUPERSEDED BY 3-643820-9	35.66[1.404]	9	-643820-9
△	SUPERSEDED BY 3-643820-8	31.70[1.248]	8	-643820-8
△	SUPERSEDED BY 3-643820-7	27.74[1.092]	7	-643820-7
△	SUPERSEDED BY 3-643820-6	23.77[.936]	6	-643820-6
△	SUPERSEDED BY 3-643820-5	19.81[.780]	5	-643820-5
△	SUPERSEDED BY 3-643820-4	15.85[.624]	4	-643820-4
△	SUPERSEDED BY 3-643820-3	11.89[.468]	3	-643820-3
△	SUPERSEDED BY 3-643820-2	7.92[.312]	2	-643820-2

1 MATERIAL: CONNECTOR - NYLON UL94-V2 (WHITE)  
 CONTACTS - 0.30[.012] THICK COPPER ALLOY  
 (BRIGHT TIN-LEAD 0.00203[.000080] MIN. THICK  
 FOR CONTACTS 643820-2 THRU 2-643820-4).  
 (MATTE WHISKER MITIGATED TIN 0.00203[.000080] MIN.  
 THICKNESS OVER NICKEL UNDERPLATE FOR  
 3-643820-2 THRU 5-643820-4).

2. CONTACTS ACCEPT 24 AWG WIRE WITH 2.41[.095] MAX INSULATION DIAMETER.

3. CONTACTS MUST ACCEPT 1.14±0.03[.045±.001] POST AND REMAIN LOCKED IN POSITION.

4 IDENTIFICATION NUMBER FOR LAST CIRCUIT MAY NOT APPEAR ON ALL ASSEMBLIES.

5. DIMENSIONS IN BRACKETS ARE IN INCHES.

6. HOUSING FEATURES ARE: CLOSED END WITH LOCKING RAMP AND POLARIZING TAB.

7 OBSOLETE PARTS: OBSOLETE CIS STREAMLINING PER D.RENAUD/D.SINISI

8 OBSOLETE PARTS

THIS DRAWING IS A CONTROLLED DOCUMENT.		DWN S. CARPENTER 09JUL2003		
DIMENSIONS: mm [INCHES]		CHK D. BOSSI 09JUL2003		
TOLERANCES UNLESS OTHERWISE SPECIFIED:		APVD D. BOSSI 09JUL2003	NAME	
0 PLC ± -		PRODUCT SPEC	MTA 156 CONNECTOR ASSEMBLY, 24 AWG, STANDARD	
1 PLC ± -		APPLICATION SPEC	SIZE	CAGE CODE
2 PLC ± -		108-1051	A2	00779
3 PLC ± 0.13 [.005]		114-1020	DRAWING NO	RESTRICTED TO
4 PLC ± -		WEIGHT	C=643820	-
ANGLES ± -		CUSTOMER DRAWING	SCALE	SHEET
FINISH			4:1	1 OF 1
1			REV	J