

ECN/PCN No.: 4112

For Manufacturer			
<b>Product Description:</b> PLASTIC SMD MEMS OSCILLATOR	<b>Abracon Part Number / Part Series:</b> ASTMKH	<input type="checkbox"/> Documentation only <input type="checkbox"/> ECN <input checked="" type="checkbox"/> EOL	<input checked="" type="checkbox"/> Series <input type="checkbox"/> Part Number
<b>Affected Revision:</b> A	<b>New Revision:</b> EOL	<b>Application:</b>	<input type="checkbox"/> Safety <input checked="" type="checkbox"/> Non-Safety
<b>Prior to Change:</b> Active <a href="https://abracon.com/Oscillators/ASTMKH.pdf">https://abracon.com/Oscillators/ASTMKH.pdf</a>			
<b>After Change:</b> EOL			
<b>Cause/Reason for Change:</b> Discontinuation of manufacturing capability.			
Change Plan			
<b>Effective Date:</b> 2/7/2022	<b>Additional Remarks:</b> N/A		
<b>Change Declaration:</b> N/A			
<b>Issued Date:</b> 2/7/2022	<b>Issued By:</b> <i>Brooke Cushman Product Engineer</i>	<b>Issued Department:</b> Engineering	
<b>Approval:</b> <i>Thomas Culhane Engineering Director</i>	<b>Approval:</b> <i>Reuben Quintanilla Quality Director</i>	<b>Approval:</b> <i>Ying Huang Purchasing Director</i>	
For Abracon EOL only			
<b>Last Time Buy (if applicable):</b> 5/7/2022	<b>Alternate Part Number / Part Series:</b> none		
<b>Additional Approval:</b>	<b>Additional Approval:</b>	<b>Additional Approval:</b>	
Customer Approval (If Applicable)			
<b>Qualification Status:</b> <input type="checkbox"/> Approved <input type="checkbox"/> Not accepted <i>Note: It is considered approved if there is no feedback from the customer 1 month after ECN/PCN is released.</i>			
<b>Customer Part Number:</b>		<b>Customer Project:</b>	
<b>Company Name:</b>	<b>Company Representative:</b>	<b>Representative Signature:</b>	
<b>Customer Remarks:</b>			

# Ultra-miniature, Low Power, 32.768kHz MEMS Oscillator

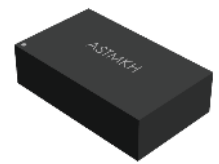

2.0 x 1.2 x 0.6mm

ASTMKH



RoHS/RoHS II compliant

## Moisture Sensitivity Level (MSL) – 1

### FEATURES:

- Ultra-miniature size: 2.0 x 1.2 x 0.6mm
- Supply Voltage: 1.2V to 3.63V (-10 ~ +70°C); 1.5V to 3.63V (-40 ~ +85°C)
- Ultra-Low Current Consumption: 1.4µA max. (core current, no load)
- Frequency Stabilities include:
  - ±75ppm over -10 to +70°C
  - ±100ppm over -40 to +85°C
- Internal power supply filtering eliminates external bypass capacitor for Vdd port.
- Proprietary NanoDrive™ Technology enables programmable output swing for lower power

### APPLICATIONS:

- Timekeeping
- Battery Management
- Mobile devices
- RTC reference clock
- Wireless accessories
- Fitness/Medical monitoring sensors
- Sport video cams

### STANDARD SPECIFICATIONS:

Parameters	Min	Typ	Max	Unit	Notes
Output Frequency (F <sub>out</sub> )	32.768			kHz	
Initial Frequency Tolerance (F <sub>tol</sub> ) <sup>(1)</sup>	-20		+20	ppm	T <sub>A</sub> = +25°C, post reflow, V <sub>dd</sub> : 1.5-3.63V
Frequency Stability over Temperature (F <sub>stab</sub> ) <sup>(2)</sup>	-75		+75	ppm	T <sub>A</sub> = -10°C to +70°C, V <sub>dd</sub> : 1.5-3.63V
	-100		+100		T <sub>A</sub> = -40°C to +85°C, V <sub>dd</sub> : 1.5-3.63V
	-250		+250		T <sub>A</sub> = -10°C to +70°C, V <sub>dd</sub> : 1.2-1.5V
Aging (@+25°C)	-1		+1	ppm	First year
Supply Voltage (V <sub>dd</sub> )	1.2		3.63	V	T <sub>A</sub> = -10°C to +70°C
	1.5		3.63		T <sub>A</sub> = -40°C to +85°C
Core Operating Current (I <sub>dd</sub> ) <sup>(3)</sup>		0.90		µA	T <sub>A</sub> = +25°C, V <sub>dd</sub> : 1.8V. No load.
			1.3		T <sub>A</sub> = -10°C to +70°C, V <sub>dd</sub> max: 3.63V. No load
			1.4		T <sub>A</sub> = -40°C to +85°C, V <sub>dd</sub> max: 3.63V. No load.
Output Stage Operating Current (I <sub>dd out</sub> ) <sup>(3)</sup>		0.065	0.125	µA/V <sub>pp</sub>	T <sub>A</sub> = -40°C to +85°C, V <sub>dd</sub> max: 1.5-3.63V. No load.
Power Supply Ramp (t <sub>vdd Ramp</sub> )			100	ms	T <sub>A</sub> = -40°C to +85°C, 0 to 90%*V <sub>dd</sub>
Start-up Time at Power-up (T <sub>start</sub> ) <sup>(4)</sup>		180	300	ms	T <sub>A</sub> = -40°C ≤ T <sub>A</sub> ≤ +50°C, valid output
			450		T <sub>A</sub> = +50°C ≤ T <sub>A</sub> ≤ +85°C, valid output
Operating Temperature Range (T <sub>use</sub> )	-10		+70	°C	Option "M"
	-40		+85		Option "L"
Period Jitter		35		ns <sub>RMS</sub>	Cycles=10000, T <sub>A</sub> = +25°C, V <sub>dd</sub> : 1.5-3.63V
<b>LVC MOS Output Option</b> (T <sub>A</sub> = -40°C to +85°C. Typical values are at T <sub>A</sub> = +25°C)					
Output Rise/Fall Time (t <sub>r</sub> /t <sub>f</sub> )		100	200	ns	10-90%(V <sub>dd</sub> ), 15pF load, V <sub>dd</sub> : 1.5-3.63V
			50		10-90%(V <sub>dd</sub> ), 5pF load, V <sub>dd</sub> ≥ 1.62V
Output Clock Duty Cycle	48		52	%	
Output Voltage	V <sub>OH</sub>	90%*V <sub>dd</sub>		V	V <sub>dd</sub> : 1.5-3.63V. I <sub>OH</sub> = -10µA, 15pF
	V <sub>OL</sub>		10%*V <sub>dd</sub>		V <sub>dd</sub> : 1.5-3.63V. I <sub>OL</sub> = 10µA, 15pF
<b>NanoDrive™(5) Programmable, Reduced Swing Output Option</b>					
Output Rise/Fall Time (t <sub>r</sub> /t <sub>f</sub> )			200	ns	30-70%(V <sub>OL</sub> / V <sub>OH</sub> ), 10pF load
Output Clock Duty Cycle	48		52	%	
AC-coupled Programmable Output Swing (V <sub>sw</sub> )		0.20 to 0.80		V	ASTMKH does not internally AC-couple. This output description is intended for a receiver that is AC-coupled. See Part Identification section for available AC-coupled signal swing options. V <sub>dd</sub> : 1.5-3.63V. 10pF load, I <sub>OH</sub> / I <sub>OL</sub> = ±0.2µA

# Ultra-miniature, Low Power, 32.768kHz MEMS Oscillator

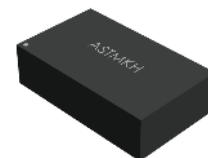

2.0 x 1.2 x 0.6mm

ASTMKH



RoHS/RoHS II compliant

(Continued)

Parameters	Min	Typ	Max	Unit	Notes
DC-biased Programmable Output Voltage High Range ( $V_{OH}$ )		0.60 to 1.225		V	$V_{dd}$ : 1.5-3.63V. $I_{OH}$ = -0.2 $\mu$ A. 10pF load. See Part Identification section for available $V_{OH}$ / $V_{OL}$ levels.
DC-biased Programmable Output Voltage Low Range ( $V_{OL}$ )		0.35 to 0.80		V	$V_{dd}$ : 1.5-3.63V. $I_{OL}$ = 0.2 $\mu$ A. 10pF load. See Part Identification section for available $V_{OH}$ / $V_{OL}$ levels.
Programmable Output Voltage Swing Tolerance	-0.055		+0.055	V	$T_A$ = -40°C to +85°C, $V_{dd}$ : 1.5-3.63V

Note:

1. Measured peak-to-peak. Tested with Agilent 53132A frequency counter. Due to the low operating frequency, the gate time must be  $\geq 100$ ms to ensure an accurate frequency measurement.
2. Stability is specified for two operating voltage ranges. Stability progressively degrades with supply voltage below 1.5V. Measured peak-to-peak. Inclusive of initial tolerance at +25°C, and variations over operating temperature, rated power supply voltage and load.
3. Core operating current does not include output driver operating current or load current. To derive total operating current (no load), add core operating current + output driver operating current, where output driver operating current =  $C_{driver} * V_{out} * F_{out}$ .
4. Measured from the time  $V_{dd}$  reaches 1.5V.
5. NanoDrive™ is a SiTime trademark.

## Absolute Maximum Ratings

Attempted operation outside the absolute maximum ratings may cause permanent damage to the part. Actual performance of the IC is only guaranteed within the operational specifications, not at absolute maximum ratings.

Parameters	Test Condition	Value	Unit
Continuous Power Supply Voltage Range ( $V_{dd}$ )		-0.5 to 3.63	V
Short Duration Max. Power Supply Voltage ( $V_{dd}$ )	$\leq 30$ minutes	4.0	V
Continuous Maximum Operating Temperature Range	$V_{dd}$ : 1.5-3.63V	105	°C
Short Duration Max. Operating Temperature Range	$V_{dd}$ : 1.5-3.63V, $\leq 30$ minutes	125	°C
Human Body Model (HBM) ESD Protection	JESD22-A114	3000	V
Charge-Device Model (CDM) ESD Protection	JESD22-C101	750	V
Machine Model (MM) ESD Protection	JESD22-A115	300	V
Latch-up Tolerance	JESD78 Compliant		
Mechanical Shock Resistance	Mil 883, Method 2002	10000	g
Mechanical Vibration Resistance	Mil 883, Method 2007	70	g
2012 SMD Junction Temperature		150	°C
Storage Temperature		-65 to +150	°C

# Ultra-miniature, Low Power, 32.768kHz MEMS Oscillator

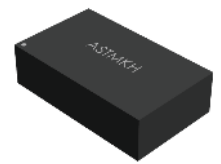

2.0 x 1.2 x 0.6mm

ASTMKH

**Pb** RoHS/RoHS II compliant

## Block Diagram

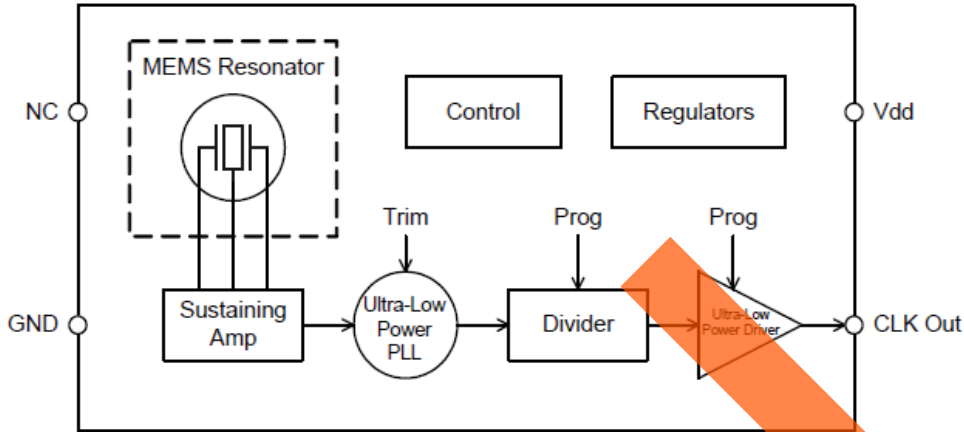

## PART IDENTIFICATION:

ASTMKH - 32.768 kHz -   -    -

Operating Temp.
M: -10°C ~ +70°C
L: -40°C ~ +85°C

Freq. Stability
P: ±75ppm (-10°C ~ +70°C only)
Q: ±100 ppm (-40°C ~ +85°C only)

Packaging
Blank: Bulk
T3: Tape & Reel (3kpcs / reel)
T10: Tape & Reel (10kpcs / reel)

Output Level Option
DCC: Rail-to-Rail LVCMOS
AA3: AC-coupled signal, swing level: 0.3V min.
D14: DC-coupled signal, V <sub>OL</sub> : 0.400V max, V <sub>OH</sub> : 1.100V min
D26: DC-coupled signal, V <sub>OL</sub> : 0.525V max, V <sub>OH</sub> : 1.225V min

# Ultra-miniature, Low Power, 32.768kHz MEMS Oscillator

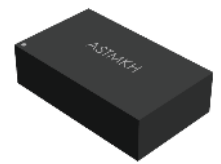

2.0 x 1.2 x 0.6mm

ASTMKH



RoHS/RoHS II compliant

Typical Performance Data (TA=25°C, Vdd=1.8V, unless otherwise stated)

**Initial Tolerance Histogram**

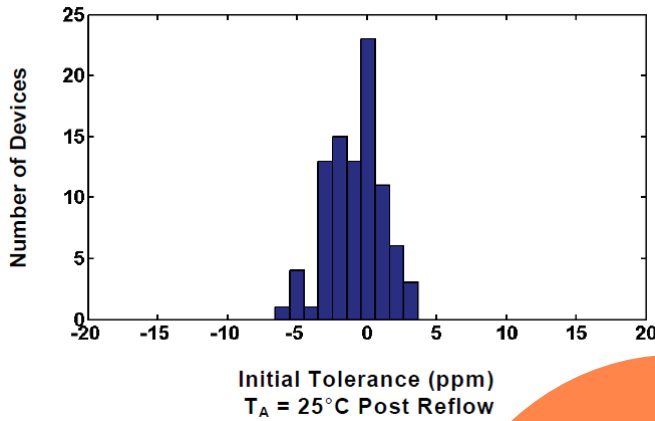

**Frequency Stability vs. Operating Temperature Range**

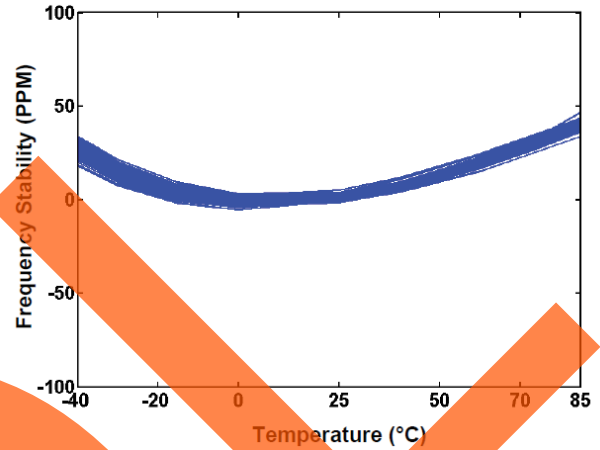

**Core Current vs Operating Temperature Range**

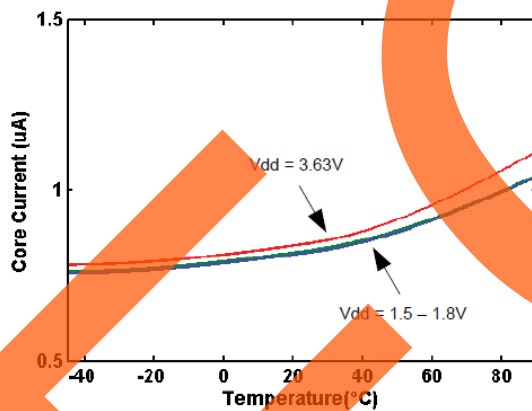

**Output Stage Current vs Operating Temperature Range**

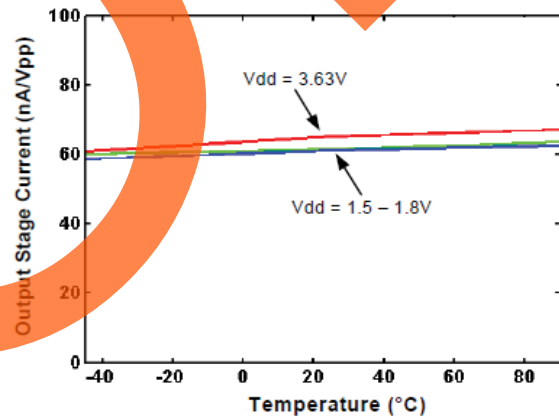

**Start-up Time**

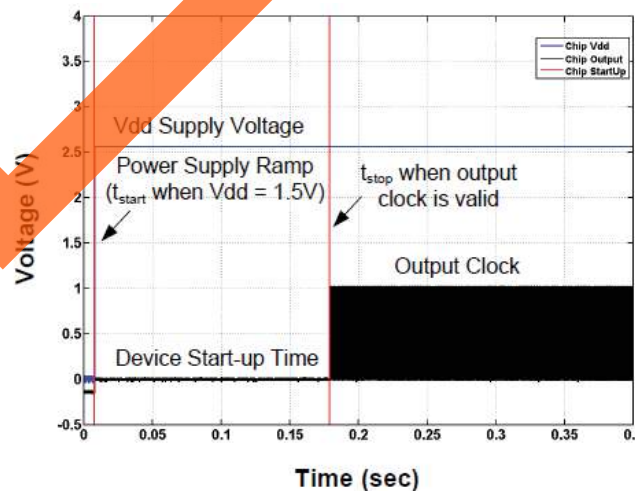

# Ultra-miniature, Low Power, 32.768kHz MEMS Oscillator

ASTMKH



RoHS/RoHS II compliant

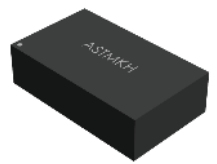

2.0 x 1.2 x 0.6mm

Typical Performance Data (TA=25°C, Vdd=1.8V, unless otherwise stated)---(Continued)

**Power Supply Noise Rejection ( $\pm 150\text{mV}$  Noise)**

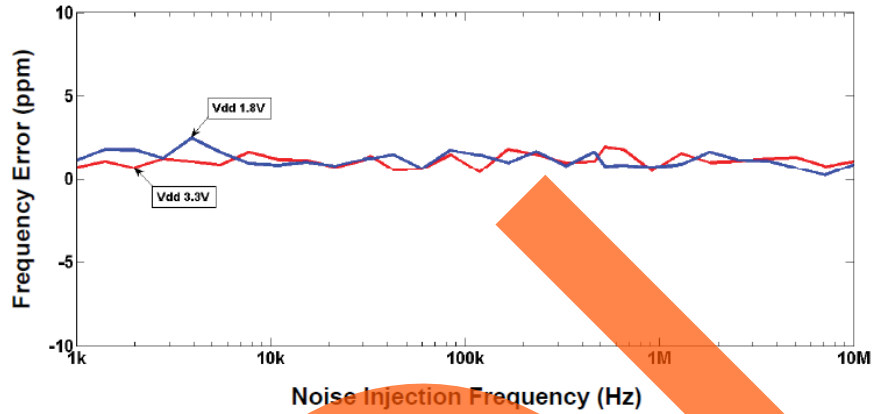

**NanoDrive™ Output Waveform ( $V_{OH} = 1.1\text{V}$ ,  $V_{OL} = 0.4\text{V}$ )**

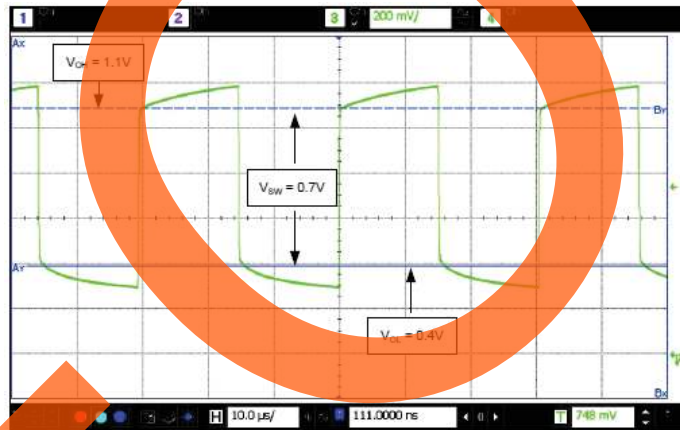

**LVC MOS Output Waveform ( $V_{swing} = 1.8\text{V}$ )**

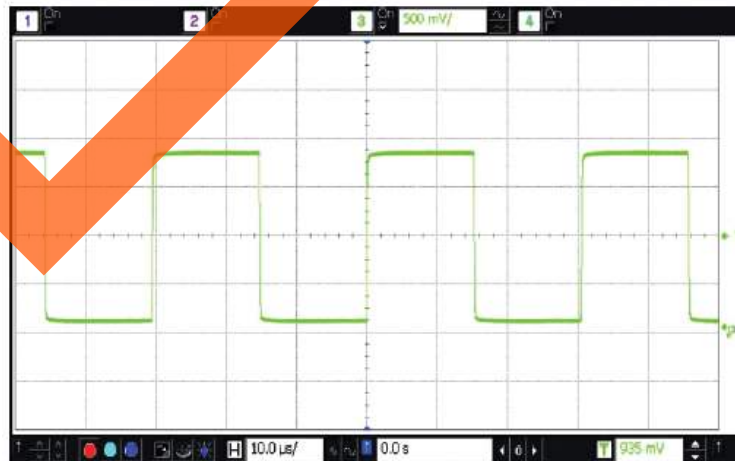

# Ultra-miniature, Low Power, 32.768kHz MEMS Oscillator

ASTMKH



RoHS/RoHS II compliant



2.0 x 1.2 x 0.6mm

## OUTLINE DIMENSION:

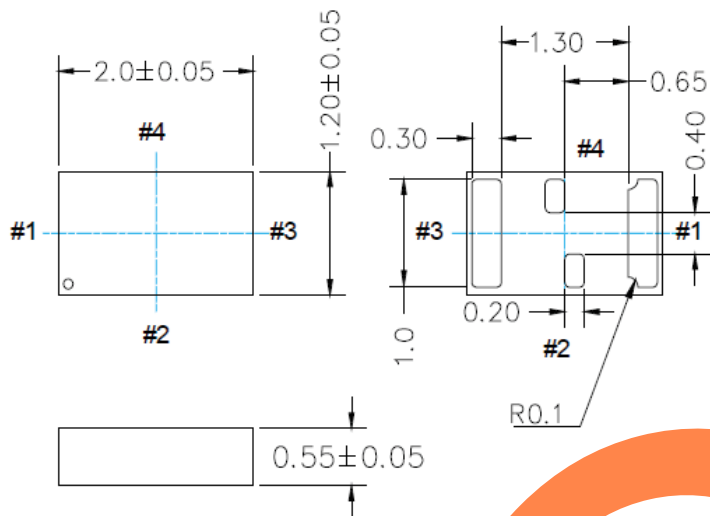

## Recommended Land Pattern

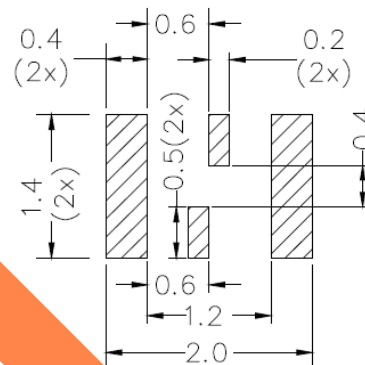

Pin	Name	I/O	Functionality
1	NC	No Connect	No connection. Will not respond to any input signal.
2	GND	Power Supply Ground	Connect to ground. All GND pins must be connected to power supply ground.
3	CLK Out	OUT	Oscillator clock output.
4	V <sub>dd</sub>	Power Supply	Connect to power supply 1.5V ≤ V <sub>dd</sub> ≤ 3.63V for operation over -40°C to +85°C temperature range. Under normal operating conditions, V <sub>dd</sub> doesn't require external bypass/decoupling capacitor(s). Internal power supply filtering will reject more than ±150mVpp with frequency components through 10MHz.

Dimensions: mm

## REFLOW PROFILE:

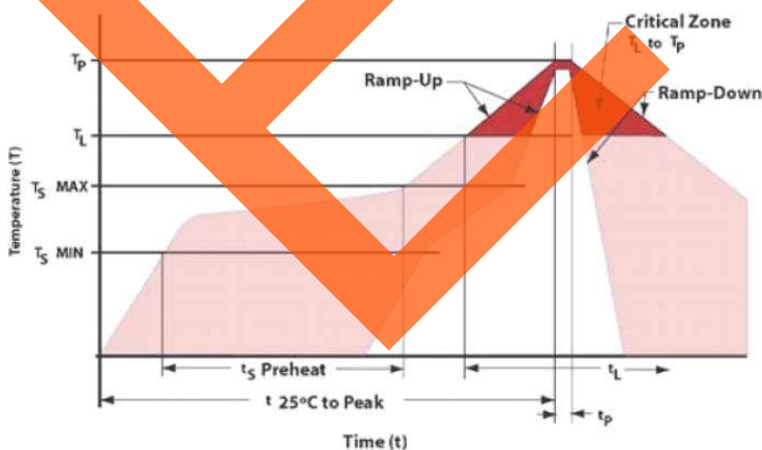

Item	Conditions
T <sub>s</sub> MAX to T <sub>L</sub> (Ramp-up Rate)	3°C/second max
Preheat	
Temperature Minimum (T <sub>s</sub> MIN)	150°C
Temperature Typical (T <sub>s</sub> TYP)	175°C
Temperature Maximum (T <sub>s</sub> MAX)	200°C
Time (t <sub>s</sub> )	60 – 180 seconds
Ramp-up Rate (T <sub>L</sub> to T <sub>p</sub> )	3°C/second max
Time Maintained Above Temperature (T <sub>L</sub> )	217°C
Time (t <sub>L</sub> )	60 – 150 seconds
Peak Temperature (T <sub>p</sub> )	260°C max
Target Peak Temperature (T <sub>p</sub> Target)	255°C
Time within 5°C of actual peak (t <sub>p</sub> )	20 – 40 seconds
Max. Number of Reflow Cycles	3
Ramp-down Rate	6°C/second max
Time 25°C to Peak Temperature (t)	8 minutes max

# Ultra-miniature, Low Power, 32.768kHz MEMS Oscillator



2.0 x 1.2 x 0.6mm

ASTMKH



RoHS/RoHS II compliant

## TAPE & REEL:

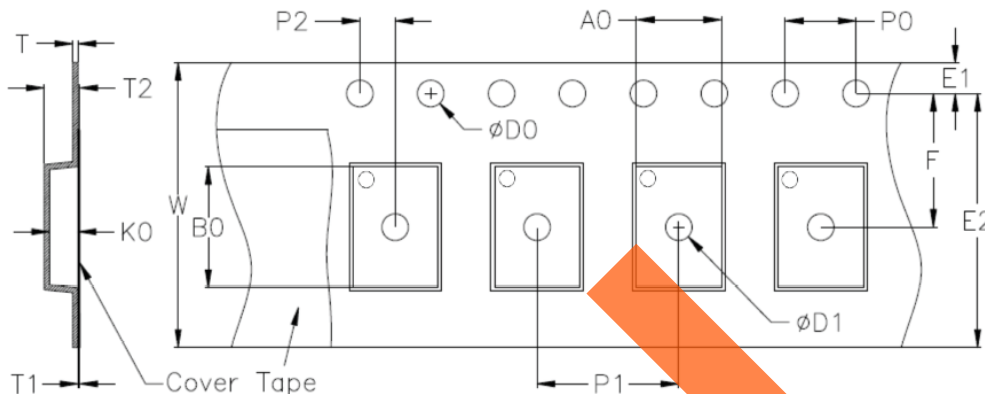

<b>D0</b>	<b>D1 min.</b>	<b>E1</b>	<b>E2 min.</b>	<b>F</b>	<b>P0</b>	<b>P1</b>	<b>P2</b>
1.55±0.05	0.18	1.75±0.1	6.05	3.5±0.05	4.0±0.1	4.0±0.1	2.0±0.05
<b>T</b>	<b>T1 max.</b>	<b>T2 max.</b>	<b>W max.</b>	<b>A0</b>	<b>B0</b>	<b>K0</b>	
0.20±0.02	NA	NA	8.3	0.96±0.03	1.66±0.03	0.63±0.03	

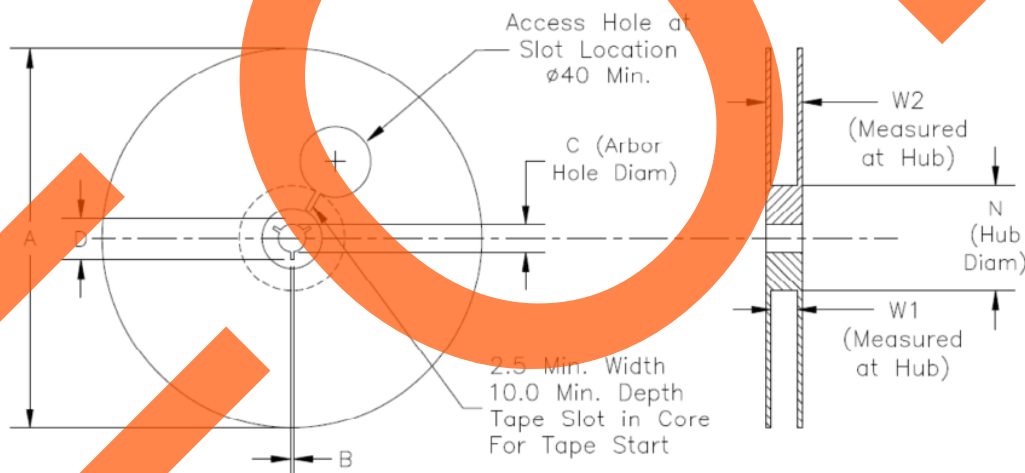

Option	A max.	B min.	C	D min.	N	W1	W2 max.
T3	180.5	1.5	13.0+0.6/-0.2	20.2	60±0.5	8.4+1.5/-0	14.4
T10	330	1.5	13.0±0.2	20.2	100±0.5	8.4+1.5/-0	14.4

T3= Tape and reel (3,000pcs/reel)

T10= Tape and reel (10,000pcs/reel)

Unit: mm

**ATTENTION:** Abracon LLC's products are COTS – Commercial-Off-The-Shelf products; suitable for Commercial, Industrial and, where designated, Automotive Applications. Abracon's products are not specifically designed for Military, Aviation, Aerospace, Life-dependent Medical applications or any application requiring high reliability where component failure could result in loss of life and/or property. For applications requiring high reliability and/or presenting an extreme operating environment, written consent and authorization from Abracon LLC is required. Please contact Abracon LLC for more information.