

# FAN1654

## 1.5A LDO, DDR Bus Termination Regulator

### Features

- Sinks and sources 1A continuous, 1.5A peak
- -40°C to +125°C Operating Range
- Load regulation:  $(VDDQ/2) \pm 40\text{mV}$
- 5mA VREF buffer tracks VTT
- On-chip thermal limiting
- Power-enhanced eTSSOP™-16 package
- Low Current Shutdown Mode
- Output Short Circuit Protection

### Applications

- DDR terminators

### Description

The FAN1654 is a low-cost bi-directional LDO specifically designed for terminating DDR memory bus. It can both sink and source up to 1A continuous, 1.5A peak, providing enough current for most DDR applications. Load regulation meets the JEDEC spec,  $VTT = (VDDQ/2) \pm 40\text{mV}$ .

The FAN1654 includes a buffered reference voltage capable of supplying up to 5mA current. On-chip thermal limiting provides protection against a combination of power overload and ambient temperature that would create an excessive junction temperature. A shutdown input puts the FAN1654 into a low power mode for laptop computer applications.

The FAN1654 regulator is available in a power-enhanced eTSSOP™-16 package, and the standard SOIC-14

### Block Diagram

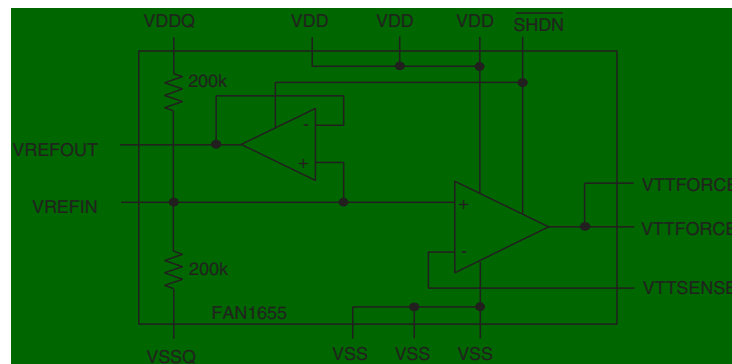

## Pin Assignments

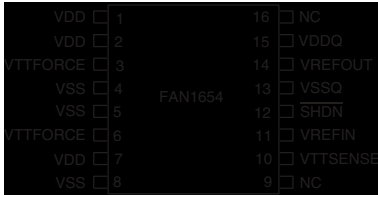

### 16-Lead Plastic eTSSOP-16

$$\theta_{JC} = 4^{\circ}\text{C/W}^*$$

\*With package power slug soldered to 0.5 square inch copper area over backside ground plane of internal power plane

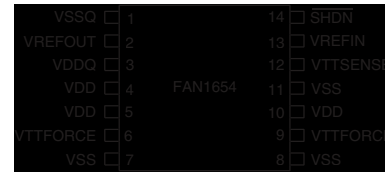

### 14-Lead Plastic SOIC

$$\theta_{JC} = 37^{\circ}\text{C/W}, \theta_{JA} = 88^{\circ}\text{C/W}$$

## Pin Definitions

Pin Number*	Pin Name	Pin Function Description
1, 2, 7 (4, 5, 10)	VDD	<b>VDD.</b> Input power for the LDO.
3, 6 (6, 9)	VTTFORCE	<b>VTT Force Output.</b>
4, 5, 8 (7, 8, 11)	VSS	<b>Power Ground.</b>
10 (12)	VTTSENSE	<b>VTT Sense.</b> Feedback for remote sense of the VTT voltage.
11 (13)	VREFIN	<b>VREFIN.</b> Alternative input for direct control of VTTOUT and VREFOUT.
12 (14)	SHDN	<b>Shutdown.</b> This active low shutdown turns off both VTT and VREFOUT. This pin has an internal pull-down, and must be externally driven high for the IC to be on.
13 (1)	VSSQ	<b>Signal Ground.</b>
14 (2)	VREFOUT	<b>Buffered Voltage Reference Output.</b>
15 (3)	VDDQ	<b>VDDQ Input.</b> Attach this pin to the VDDQ supply to generate VTT and VREFOUT.
9,16	NC	No Internal Connection

\* Pin Numbers in brackets are for the SOIC-14 package

## Typical Application

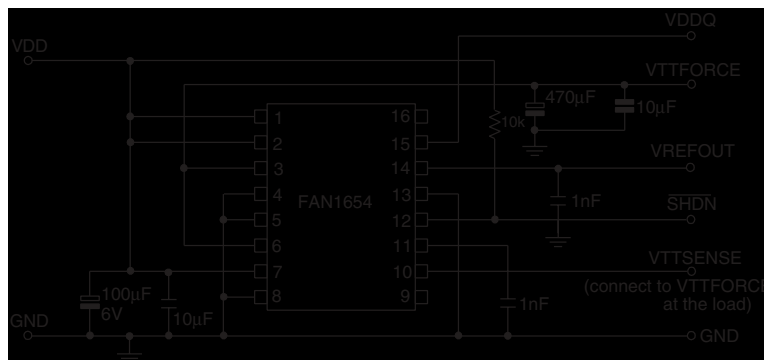

Figure 1. (eTSSOP pinout shown)

# Typical Performance Characteristics

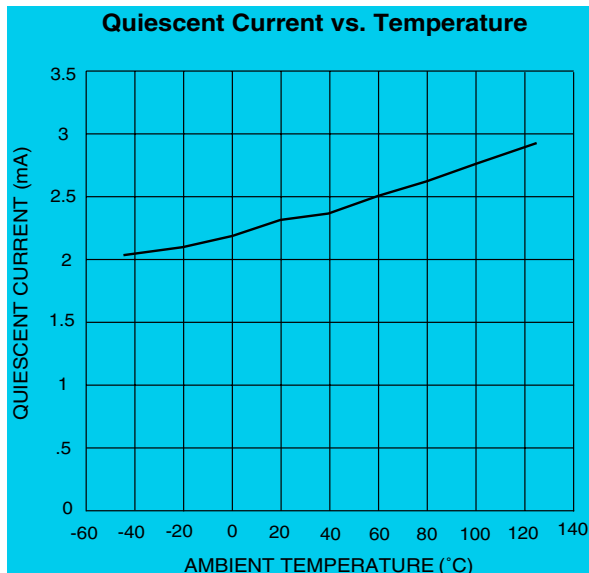

Figure 2

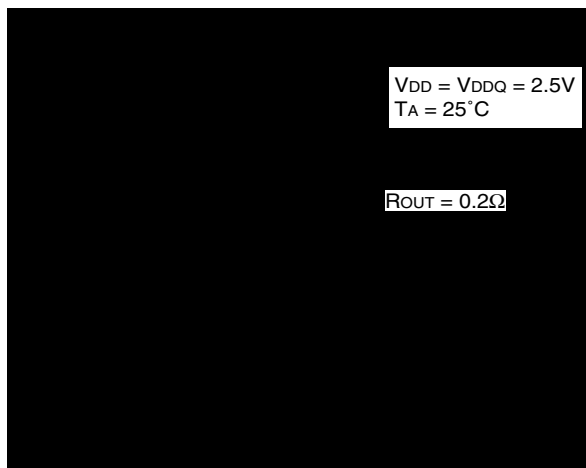

Figure 3

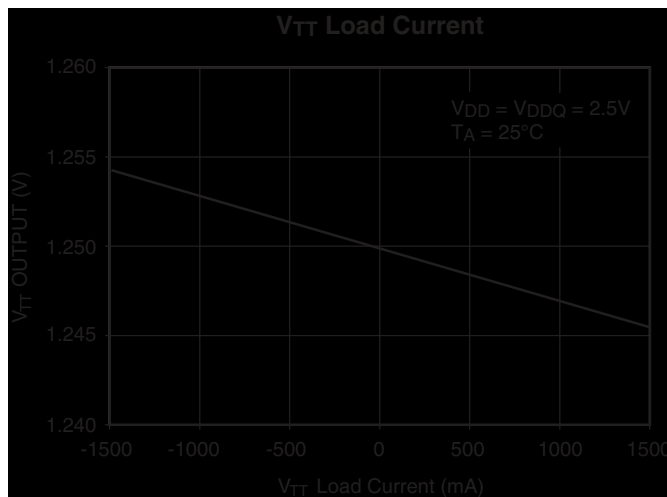

Figure 4

## Absolute Maximum Ratings

Supply Voltage VDD, VDDQ	6V
Junction Temperature, T <sub>J</sub>	150°C
Storage Temperature	-65 to 150°C
Lead Soldering Temperature, 10 seconds	300°C
Power Dissipation, P <sub>D</sub>	1.4W

## Recommended Operating Conditions

Parameter	Conditions	Min.	Typ.	Max.	Units
Supply Voltage VDD		2.3	2.5	3.6	V
Supply Voltage VDDQ		2.2	2.5	3.0	V
Ambient Operating Temperature		-40		125	°C
VREFIN		1.1	1.25	1.5	V

## Electrical Characteristics

(VDD = VDDQ = 2.5V ± 0.2V, and T<sub>A</sub> = 25°C using circuit in Figure 1, unless otherwise noted.)

The • denotes specifications which apply over the specified operating temperature range.

Parameter	Conditions	Min.	Typ.	Max.	Units	
VTT Output Voltage	I <sub>OUT</sub> = 0A, VREFIN = open	VDDQ = 2.3V •	1.135	1.150	1.165	V
		VDDQ = 2.5V •	1.235	1.250	1.265	V
		VDDQ = 2.7V •	1.335	1.350	1.365	V
	I <sub>OUT</sub> = ±1A, VREFIN = open	VDDQ = 2.3V	1.110	1.150	1.190	V
		VDDQ = 2.5V	1.210	1.250	1.290	V
		VDDQ = 2.7V	1.310	1.350	1.390	V
VTT Output Slew Rate	Cl <sub>oad</sub> = 10μF		0.1		V/μsec	
VTT Leakage Current	SHDN = 0V	• -50		50	μA	
VTT Current Limit			±2		A	
VREFIN Input Impedance			100		KΩ	
VREFOUT Output Voltage	No load	VREFIN = 1.150V •	1.145	1.150	1.155	V
		VREFIN = 1.250V •	1.245	1.250	1.255	V
		VREFIN = 1.350V •	1.345	1.350	1.355	V
VREFOUT Output Current	VDDQ = 2.3V	• -5		5	mA	
VREFOUT Leakage Current	SHDN = 0V	• -10		10	μA	
SHDN Logic High		• 1.667			V	
SHDN Logic Low		•		0.800	V	
IDD Supply Current	No load, SHDN = 2.7V	•	3	10	mA	
VDDQ Leakage Current	SHDN = 0V	•	6	10	μA	
VDD Leakage Current	SHDN = 0V	•	3	50	μA	
SHDN Input Current	SHDN = 2.7V	•	50	75	μA	
Over-Temperature Shutdown			155		°C	
Over-Temperature Hysteresis			30		°C	

## Mechanical Dimensions

### 16 Lead eTSSOP

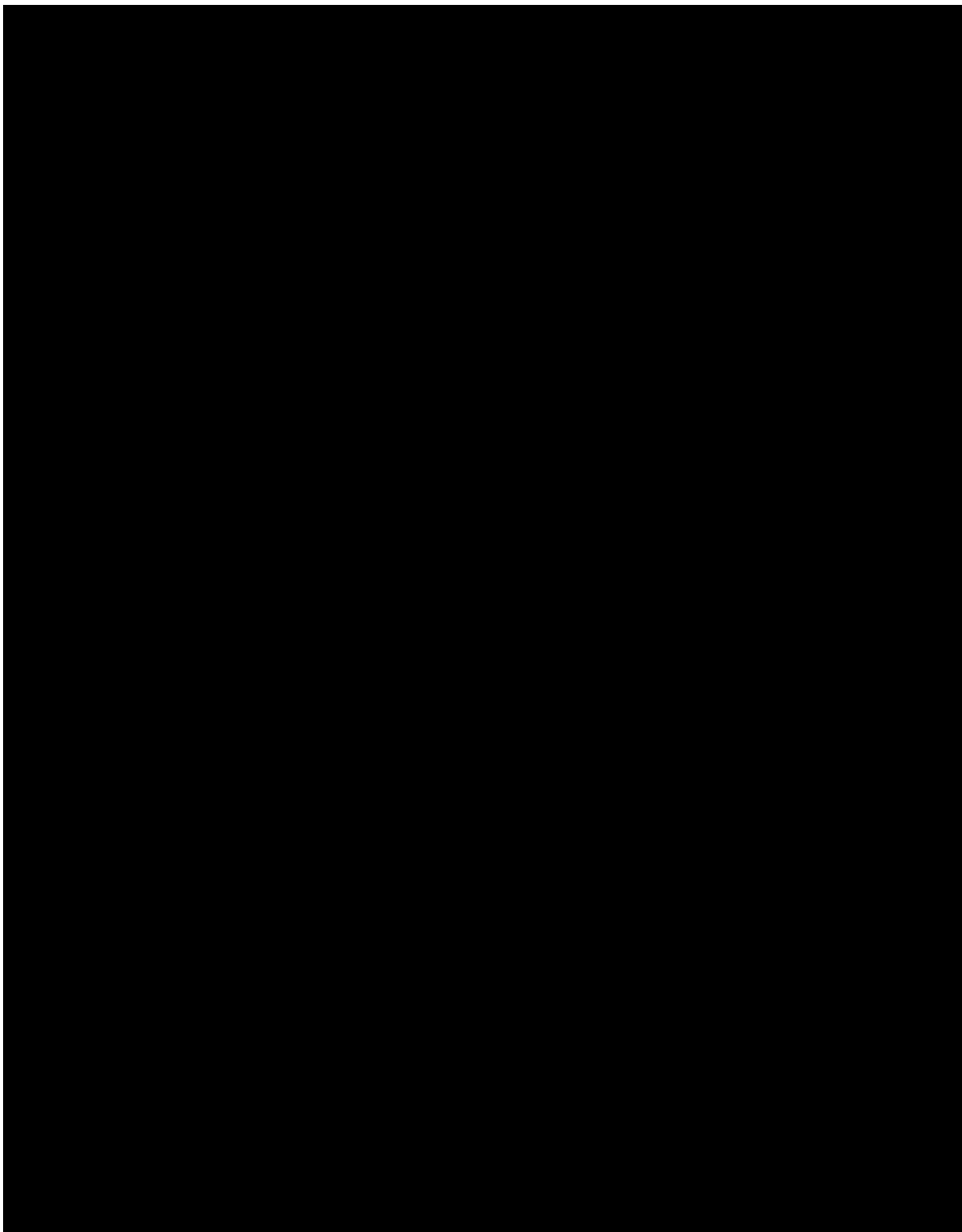

## Mechanical Dimensions

### 14-Lead SOIC

**NOTES:**

1. This package conforms to JEDEC MS-012, variation AB, ISSUEC dated May, 1990.
2. All dimensions are in millimeters
3. Standard lead finished
  - 200 microinches / 5.08 microns min.
  - Lead/Tin (solder) on copper



## Ordering Information

Product Number	Package
FAN1654MTF	eTSSOP-16
FAN1654MTFX	eTSSOP-16 in tape and reel
FAN1654M	SOIC-14
FAN1654MX	SOIC-14 in tape and reel

### LIFE SUPPORT POLICY

FAIRCHILD'S PRODUCTS ARE NOT AUTHORIZED FOR USE AS CRITICAL COMPONENTS IN LIFE SUPPORT DEVICES OR SYSTEMS WITHOUT THE EXPRESS WRITTEN APPROVAL OF THE PRESIDENT OF FAIRCHILD SEMICONDUCTOR CORPORATION. As used herein:

1. Life support devices or systems are devices or systems which, (a) are intended for surgical implant into the body, or (b) support or sustain life, and (c) whose failure to perform when properly used in accordance with instructions for use provided in the labeling, can be reasonably expected to result in a significant injury of the user.
2. A critical component in any component of a life support device or system whose failure to perform can be reasonably expected to cause the failure of the life support device or system, or to affect its safety or effectiveness.