

REVISIONS					
REV	ECO	DESCRIPTION	DATE	BY	APPR
B1	-	RELEASED DRAWING	JAN-18-2014	ARROW	TOMMY

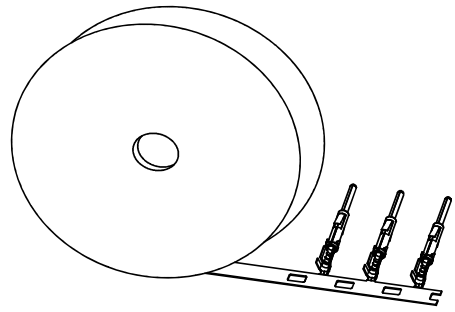

CONTACT ORIENTATION ON ROLL

**NOTES : (UNLESS OTHERWISE SPECIFIED)**

1. MATERIAL :
  - 1.1 CONTACT BODY : COPPER ALLOY.
  - 1.2 OUTER SPRING : STAINLESS STEEL.
2. SPECIFICATIONS :
  - 2.1 CURRENT RATING : 13A MAX.
  - 2.2 TERMINATION TYPE : CRIMPING.
  - 2.3 WIRE RANGE : 16~18AWG.
  - 2.4 WIRE INSULATION DIA(MAX):Ø3.2mm.
3. ROHS COMPLIANT.
4. ALL DIMENSIONS ARE FOR REFERENCE USE ONLY.
5. AVAILABLE TOOLS :
  - 5.1 HAND CRIMPER : MFX-3954.
  - 5.2 CRIMP APPLICATOR : MFX-3957.
  - 5.3 EXTRACTION TOOL : QXRT16.

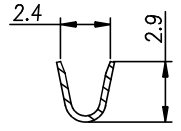

SECTION A-A

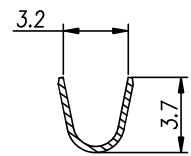

SECTION B-B

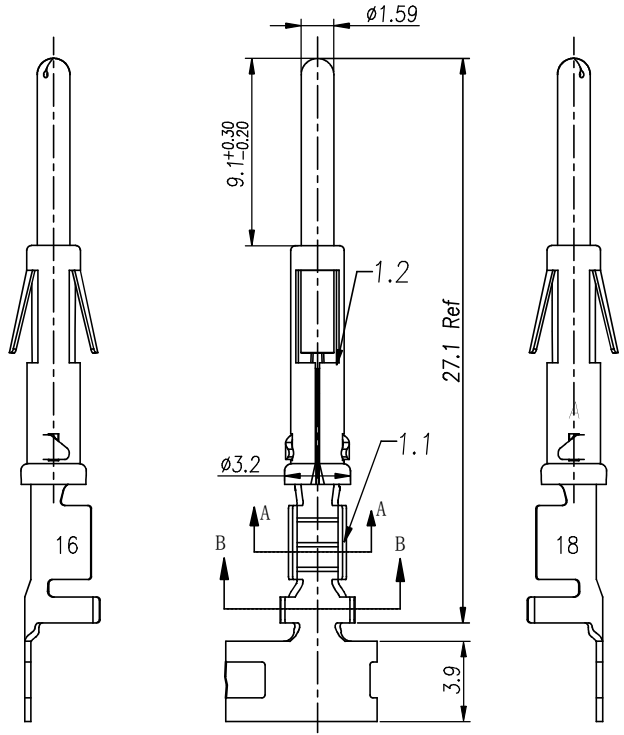

P/N	CONTACT PLATING(MATING AREA)
SP16M1T	TIN PLATING OVER NICKEL.
SP16M1F	GOLD FLASH PLATING OVER NICKEL.
SP16M1G10	10µ" GOLD PLATING OVER NICKEL.
SP16M1G15	15µ" GOLD PLATING OVER NICKEL.
SP16M1G30	30µ" GOLD PLATING OVER NICKEL.

QUANTITY	PART NUMBER	DESCRIPTION	ITEM
<b>MATERIALS LIST</b>			
UNLESS OTHERWISE SPECIFIED 1) All dimensions are in metric(mm). 2) Tolerances are as follows: 1 PL DEC ±0.30   Fractions: ±1/64 2 PL DEC ±0.15   Angles: ±1° 3 PL DEC ±0.08 3) Note reference =		SIGNATURES DRAWN: ARROW CHECKED: ENGINEER: APPROVAL:	DATE JAN-17-2014
MATERIAL SPECIFICATIONS: CUSTOMER:		 Sine Systems - www.amphenol-sine.com 44724 Morley Drive Clinton Township, MI 48036	
PROCESS SPECIFICATIONS: NEXT ASSY:		THIS DRAWING IS SUPPLIED FOR INFORMATION ONLY. DESIGN FEATURES, SPECIFICATIONS AND PERFORMANCE DATA SHOWN HEREON ARE THE PROPERTY OF THE AMPHENOL CORPORATION. NO RIGHTS OF REPRODUCTION ARE IMPLIED. ALL DIMENSIONS ARE SUBJECT TO NORMAL MANUFACTURING VARIATIONS.	ECO-MATE, PIN CONTACT STAMPED, 16-18AWG, SIZE 16 DWG NO: SP16M1XX REVISION: B1
SIZE: B C- SCALE: NONE		SHEET 1 OF 1	

TITLE: ECO-MATE,PIN CONTACT, STAMPED, 16-18AWG, SIZE 16  
 DWG NO: SP16M1XX  
 REV: B1  
 SH: 1  
 OF: 1