

Features

Power Module

- AEC-Q100 qualified constant current power module with integrated shielded inductor
- 36VDC input voltage buck regulator
- 1.5A output current with 0-100% PWM dimming
- SCP, OCP, OTP, and UVLO protection
- 3.0 x 5.0mm low profile QFN package
- Enable, fault, thermal shutdown & soft start functions
- -40 to 125°C operating temperature

RECOM

DC/DC Converter

RPY-1.5Q

1.5 Amp QFN Package



Description

The RPY-1.5Q is an automotive grade constant current source buck regulator designed for driving high power LEDs. The integrated inductor means that a complete LED driver can be realized in a compact 3mm x 5mm x 1.6mm thermally-enhanced QFN package with a maximum current output of up to 1500mA set with an external sense resistor. The input voltage range is from 4 to 36VDC, allowing 5V, 12V, or 24V supply voltages to be used. The output is fully protected against continuous short-circuits, input under-voltage, output overcurrent, or over-temperature conditions. A fault indicator flags thermal shutdown or LED open/short circuit conditions. Applications include dimmable LED lighting, visible or IR LED illumination for drones and robotic camera systems, or precision high current CC sources for test and measurement use.

Selection Guide

Part Number	Input Voltage Range [VDC]	Output Voltage [VDC]	Output Current [mA]	Efficiency typ. ⁽¹⁾ [%]
RPY-1.5Q	4 - 36	0.8 - 34.8	0-1500	95

Notes:

Note1: Tested at $V_{IN}= 36VDC$, $V_{CTRL/DIM}= 2VDC$, $V_{OUT}= 2x 3VDC$ or 2 series LED, $I_{OUT}= 1.5A$, $f_{sw}= 2.2MHz$

Model Numbering

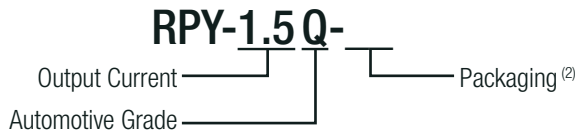

Notes:

Note2: Add suffix "-R" for tape and reel packaging
Add suffix "-CT" for bag packaging (refer to **"PACKAGING INFORMATION"**)

Specifications

ABSOLUTE MAXIMUM RATINGS (exceeding these ratings may damage the device)				
Parameter	Symbol	Min.	Typ.	Max.
Absolute Maximum Voltage	V_{IN}	-0.3VDC		40VDC
	$V_{CTRL/DIM}$	-0.3VDC		6VDC
	V_{SW}	-0.3VDC		$V_{IN} + 0.3VDC$
	V_{OUT}	-0.3VDC		$V_{IN} + 0.3VDC$
	V_{BST}	-0.3VDC		$V_{SW} + 6VDC$
	others	-0.3VDC		6VDC
Maximum Continuous Power Losses ⁽³⁾	@ $T_{AMB} = 25^{\circ}C$			2.7W
Junction Temperature	T_J			150°C
Lead Temperature				260°C
Storage Temperature		-65°C		+150°C

Notes:
Note3: Maximum power losses = $(150-T_{amb})/46$. Exceeding this value will activate thermal protection.



<https://www.recom-power.com/pdf/Eval-Boards/RPY-1.5Q-Q-EVM-1.pdf>

Specifications

OPERATING CONDITIONS ($V_{IN}= 36VDC$, $I_{OUT}= 1.5A$ $T_{AMB}= +25^{\circ}C$; tested with RECOM evaluation module: RPY-1.5Q-EVM-1 unless otherwise stated)

Parameter	Condition	Min.	Typ.	Max.
Input Voltage Range		4VDC		36VDC
V_{IN} Under-voltage Lockout Threshold	DC-DC ON	3.2VDC	3.5VDC	3.8VDC
	DC-DC OFF	2.8VDC	3.1VDC	3.4VDC
V_{IN} Under-voltage Lockout Threshold Hysteresis			400mV	
Output Voltage Range		0.8VDC		34.8VDC
Standby Current	DC-DC OFF			12 μ A
Switching Frequency		1800kHz	2200kHz	2600kHz
Feedback Voltage	$T_{AMB} = 25^{\circ}C$	192mV	200mV	208mV
	$T_{AMB} = -40^{\circ}C$ to $+125^{\circ}C$	184mV	200mV	216mV
Feedback Current	$V_{FB}= 820mV$		30nA	100nA
Start-up Time		46ms		
Rise-time	internal soft start		0.9ms	

Typical Application

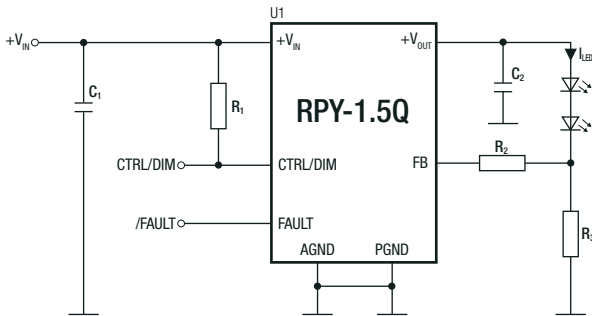

C1 (C _{IN})	R1	R2	R3	C2 (C _{OUT})
10 μ F	1M Ω	100k Ω	400m Ω	10 μ F

The typical performance and circuit waveforms are shown in the **Typical Performance Characteristics** section. For more device applications, please refer to the related evaluation board datasheet [RPY-1.5Q-EVM-1](#)

SAFE OPERATING AREA

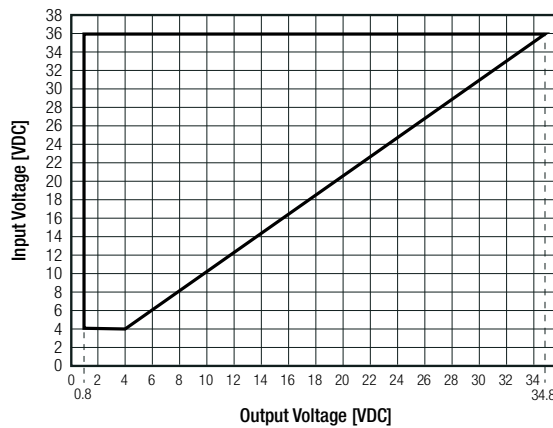

CTRL OPERATING CONDITIONS ($V_{IN}= 36VDC$, $I_{OUT}= 1.5A$ $T_{AMB}= +25^{\circ}C$; tested with RECOM evaluation module: RPY-1.5Q-EVM-1 unless otherwise stated)

Parameter	Condition	Min.	Typ.	Max.
CTRL Rising Threshold		1.1VDC	1.45VDC	1.8VDC
CTRL Falling Threshold		0.7VDC	1VDC	1.3VDC
CTRL Input Current	$V_{CTRL}= 2VDC$		5nA	10nA
CTRL Frequency Range ⁽⁴⁾		100Hz		2kHz
CTRL OFF delay		10ms	25ms	50ms

Notes:

Note4: Apply an external, 100Hz to 2kHz, PWM waveform to EN/DIM for PWM dimming. The average current is proportional to the PWM duty. The minimum amplitude of the PWM signal is 1.8V.

Specifications

FAULT

Parameter	Condition	Min.	Typ.	Max.
FAULT Over Voltage Detection			140%	
FAULT Over Voltage Detection Hysteresis			20%	
FAULT Detection Delay			10µs	
FAULT Sink Current Capability			0.4VDC	
FAULT Leakage Current			100nA	

The RPY-1.5Q has fault indication (FAULT) which is the open drain of a MOSFET and should be connected to VCC or another voltage source through a resistor (e.g. 100kΩ). FAULT is pulled high during normal operation. During the error conditions of output short circuit, open circuit, or thermal shutdown, FAULT is pulled down to indicate a fault status.

THERMAL OPERATING CONDITIONS (V_{IN}= 36VDC, I_{OUT}= 1.5A; tested with RECOM evaluation module: RPY-1.5Q-EVM-1 unless otherwise stated)

Parameter	Condition	Min.	Typ.	Max.
Operating Junction Temperature		-40°C		+125°C
Thermal Impedance	junction to ambient		46K/W	
	case to ambient		30K/W	
Thermal Shutdown	Junction Temperature= 170°C			auto recovery after cool down

Notes:

Note6: Tested with RECOM evaluation module: [RPY-1.5Q-EVM-1](#)

Thermal Derating
(I_{OUT}= 1.5A)

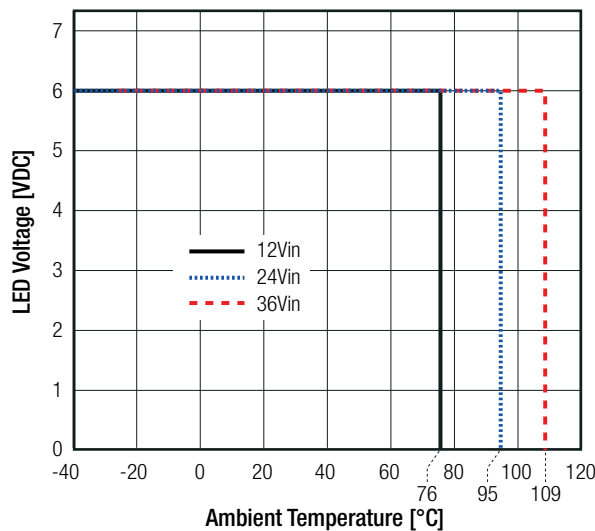

OUTPUT CURRENT SETTING

The external resistor R₃ divider sets the output current (see “*Typical Application*”) and should be approximately 400mΩ. R₃ can then be calculated with below equation. The resistor (R₂) sets the feedback loop bandwidth. The lower the R₂ is, the higher the bandwidth. A high BW may cause insufficient phase margin, resulting in loop instability. R3 Ensure that Sense resistor is capable of handling defined current. Thermal drift and resistor tolerance will have an impact on current stability.

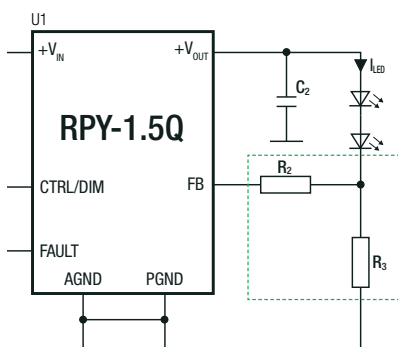

Calculation:

$$I_{LED} = \frac{0.2VDC}{R_3}$$

Example:

$$I_{LED} = \frac{0.2}{0.4} = 0.5$$

V _{FB} [VDC]	I _{LED} [A]	R ₂ [kΩ]	R ₃ [Ω]
0.2	0.35	220	0.57
	0.5	200	0.4
	0.7	175	0.286
	1.05	150	0.19
	1.5	100	0.133

Specifications

TYPICAL PERFORMANCE CHARACTERISTICS ($V_{IN}= 36VDC$, $I_{LED}= 1.5A$, $T_{AMB}= +25^{\circ}C$; tested with RECOM evaluation module: RPY-1.5Q-EVM-1)

Efficiency vs. Output Voltage

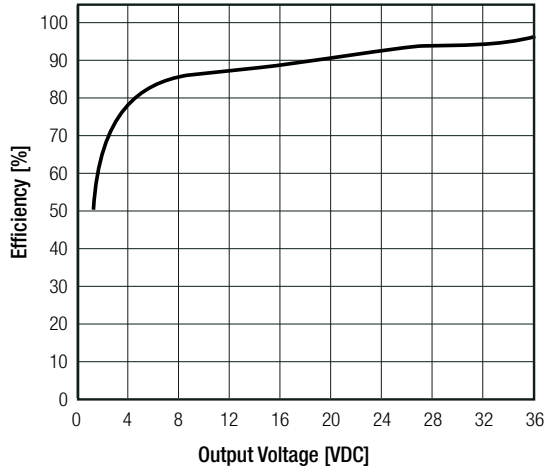

Deviation vs. Output Voltage

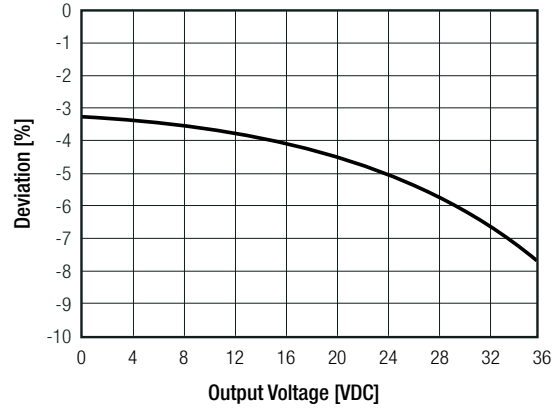

PWM DIMMING ($V_{IN}= 36VDC$, $I_{LED}= 1.5A$, $T_{AMB}= +25^{\circ}C$; tested with RECOM evaluation module: RPY-1.5Q-EVM-1 unless otherwise stated)

Parameter	Condition	Min.	Typ.	Max.
CTRL/DIM frequency		100Hz		2kHz
PWM Voltage		1.8VDC		
PWM on time at start up		2s		

Dimming tested with RECOM EVM board RPY-1.5Q-EVM-1, with 100Hz to 2kHz and PWM waveform to CTRL/DIM.

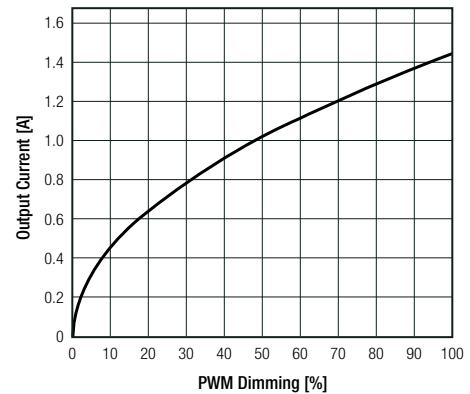
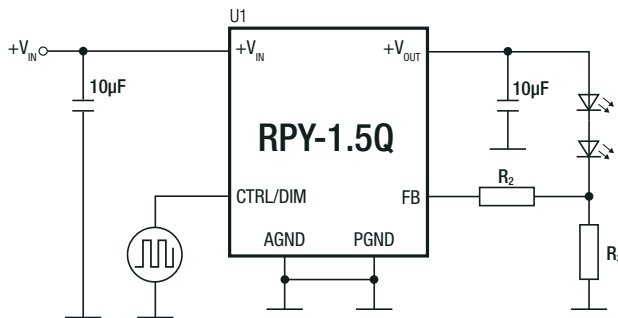

ANALOG DIMMING ($V_{IN}= 4-36VDC$, $I_{LED}= 1.5A$, $T_{AMB}= +25^{\circ}C$, unless otherwise stated)

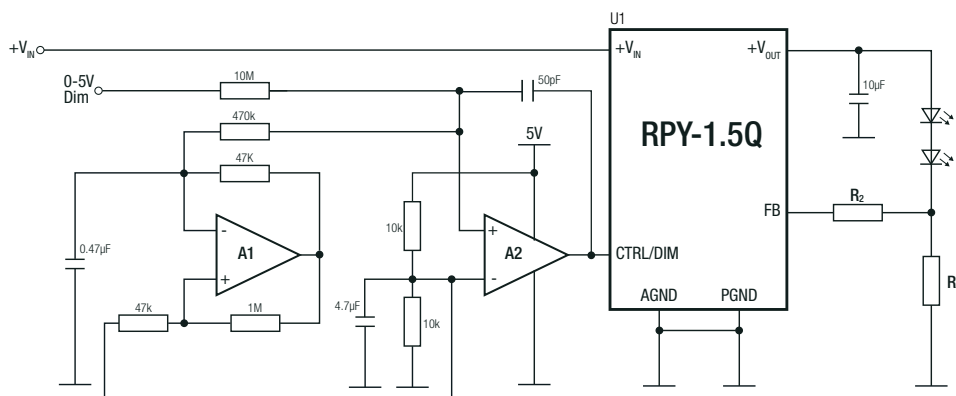

Specifications

ENVIRONMENTAL

Parameter	Condition	Value
ESD	human-body model (HBM), ANSI/ESDA/JEDEC JS-001	±2kV
	charged-device model (CDM), JEDEC JESD22-C101	±0.75kV
Moisture Sensitive Level	MSL peak temp. ⁽⁷⁾	Level 3, 260°C, 168hrs

Notes:
Note7: The Moisture Sensitivity Level rating is according to the JEDEC industry standard classifications and peak solder temperature

SAFETY AND CERTIFICATIONS

Certificate Type (Safety)	Standard
RoHS2	RoHS 2011/65EU + AM2015/863

DIMENSION AND PHYSICAL CHARACTERISTICS

Parameter	Type	Value
Material	case	plastic
Dimension (LxWxH)		3.0 x 5.0 x 1.6mm
Weight		0.095g

Dimension Drawing (mm)

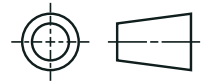
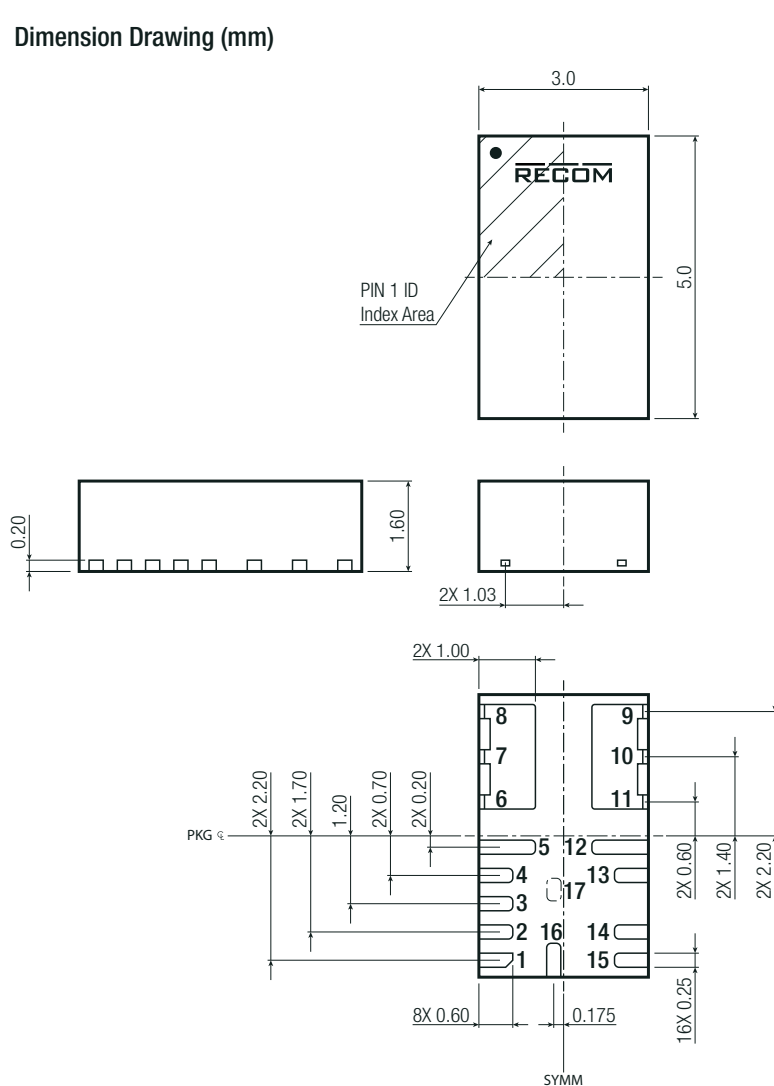

Pin Information

Pin #	Function	Description
1	FAULT	Open drain output fault indicator which is pulled low when the LED is short, open, or when thermal shutdown occurs.
2	CTRL/DIM	CTRL/DIM control. Pull CTRL/DIM high to enable the RPY-1.5Q. Apply a 100Hz to 2kHz external clock to CTRL/DIM for PWM dimming.
3	FB	Feedback Voltage
4	VCC	Internal 4.9VDC LDO output.
5	AGND	Analog ground. Reference ground of logic circuit. AGND is connected to PGND internally.
6, 7, 8, 12	SW	Switch node. Connect 6, 7, and 8 to large copper pad for optimal heat dissipation.
9, 10, 11	Vout	Power Output. Connect LED+ to VOUT. An output capacitor is needed between VOUT and PGND
13	DNC	Do not connect. Must be soldered to an isolated pad.
14, 15	PGND	Power Ground. Connect these pins to the power ground plane on the PCB.
16	Vin	Input Voltage. Connect a low-ESR low-inductance external bypass capacitor between this pin and GND as close to the pins as possible.
17	DNC	Do not connect. Leave Floating

Tolerances: according to JEDEC MO-220
Lead side is wettable and coplanarity shall be 0.10mm max. (optional)

continued on next page

Specifications

Wettable Flank version available on request, please contact RECOM

Top View

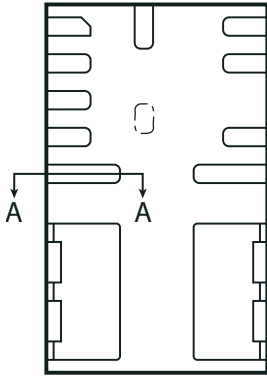

Section A-A

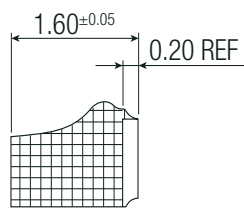

Recommended Footprint Details (Top View)

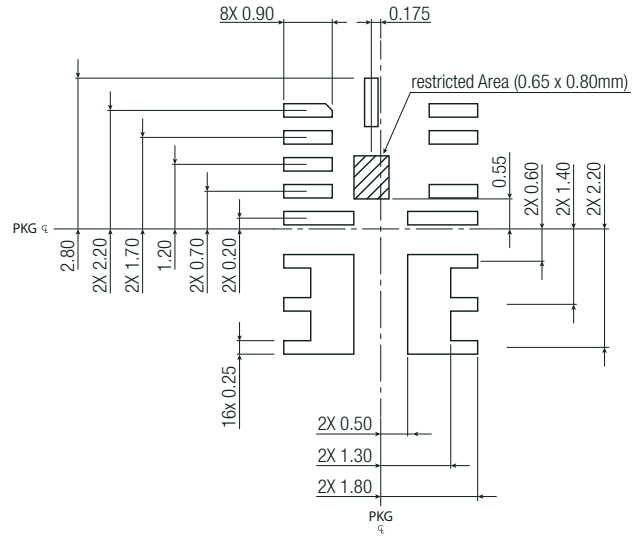

SOLDERING

Profile Feature	PB-Free Assembly
Preheat	
minimum Temperature (TS_min)	155°C
maximum Temperature (TS_max)	245°C
Time (tS)	100s-300s
Liquidus	
Temperature (TL)	217°C
Time (tL)	30-60s
Peak Temperature (TP)	245°C
Time remaining around Peak Temperature	10s
max Ramp Down Rate (from Ts_max to TP)	5K/s
max Ramp Up Rate	3K/s
max time from 25°C to Peak Temperature (TP)	8min

- 1 Pb-Free assembly is recommended according to JEDEC J-STD020.
- 2 Ensure that the peak reflow temperature does not exceed 240°C ±5°C as per JEDEC J-STD020
- 3 The reflow time period during peak temperature of 240°C ±5°C should not exceed 30 seconds.
- 4 Reflow time above liquids (217°C) should not exceed 150 seconds.
- 5 For solder paste use a standard SAC Alloy such as SAC 305, type 3 or higher.
- 6 Other soldering methods (e.g. vapor-phase) are not verified and have to validate by the customer on his own risk.

Soldering temp. graph

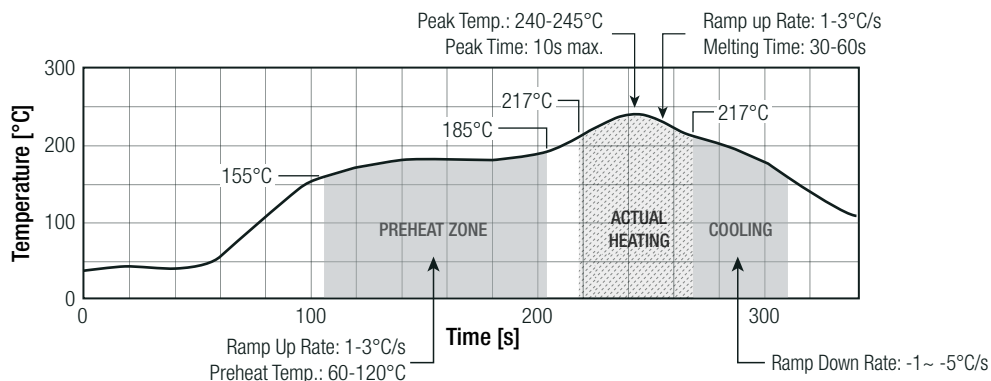

Specifications

PCB LAYOUT SUGGESTION

Efficient PCB layout, especially of the input capacitor placement, is critical for stable operation. For best results follow the guidelines below.

1. Connect a large ground plane to PGND pins 14 and 15 directly. If the bottom layer is a ground plane, add vias near GND.
2. Ensure that the high-current paths at GND and VIN have short, direct, and wide traces.
3. Place the ceramic input capacitor close to VIN and GND.
4. Keep the connection of the input capacitor and VIN as short and wide as possible.
5. Place the external feedback resistors close to the chip.
6. Use multiple vias to connect power planes to internal layers.

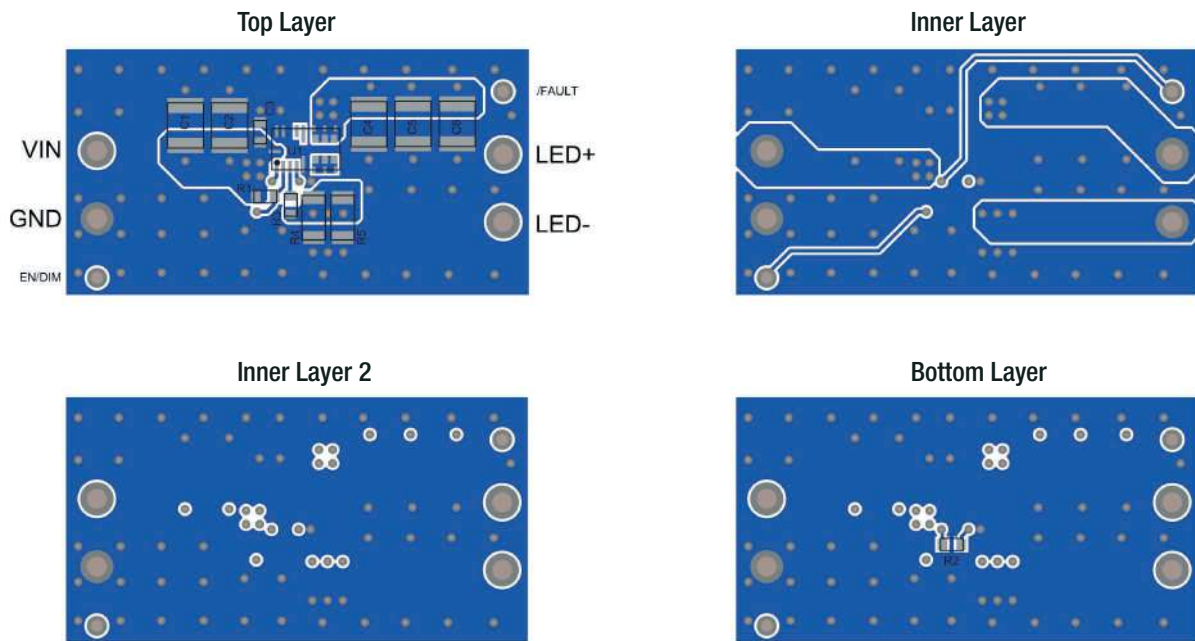

PACKAGING INFORMATION

Parameter	Type	Value
Packaging Dimension (LxWxH)	reel (diameter + width)	Ø177.8 x 12.4mm
	tape and reel (carton)	260.0 x 240.0 x 60.0mm
	moisture barrier bag ("-CT")	100.0 x 100.0 x 30mm
Packaging Quantity	tape and reel	500pcs
	moisture barrier bag ("-CT")	10pcs
Tape Width		12mm
Storage Temperature Range		-65°C to +150°C

The product information and specifications may be subject to changes even without prior written notice. The product has been designed for various applications; its suitability lies in the responsibility of each customer. The products are not authorized for use in safety-critical applications without RECOM's explicit written consent. A safety-critical application is an application where a failure may reasonably be expected to endanger or cause loss of life, inflict bodily harm or damage property. The applicant shall indemnify and hold harmless RECOM, its affiliated companies and its representatives against any damage claims in connection with the unauthorized use of RECOM products in such safety-critical applications.