



ICPL0600 / ICPL0601 / ICPL0611

DESCRIPTION

The ICPL0600, ICPL0601 and ICPL0611 devices each consist of an infrared emitting diode, optically coupled to a high speed integrated photo detector logic gate with a strobable output.

These devices belong to Isocom Compact Range of Optocouplers.

FEATURES

- Half Pitch 1.27mm
- High Speed 10Mbit/s
- 10kV/ μ s min. Common Mode Transient Immunity (ICPL0611)
- High AC Isolation voltage 3750V_{RMS}
- Guaranteed Performance from -40°C to 85°C
- Wide Operating Temperature Range -40°C to 100°C
- Logic Gate Output
- Pb Free and RoHS Compliant
- Halogen Free
- Safety Approvals Pending

APPLICATIONS

- Line Receivers, Data Communication
- LSTTL to TTL, LSTTL or 5V CMOS
- Data Multiplexing
- Pulse Transformer Replacement
- Switch Mode Power Supplies
- Ground Loop Elimination
- Computer Peripheral Interface

ORDER INFORMATION

- Add T&R after PN for Surface Mount Tape & Reel

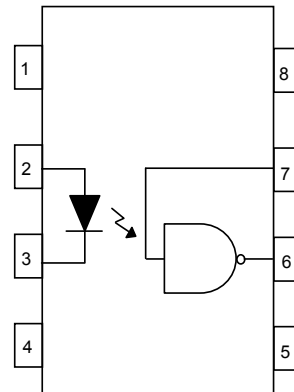

1. No Connection
2. Anode
3. Cathode
4. No Connection
5. Gnd
6. Vout
7. V_E
8. V_{CC}

A 0.1 μ F bypass capacitor must be connected between pins 8 and 5.

ABSOLUTE MAXIMUM RATINGS (T_A = 25°C)

Input Diode

Forward Current	20mA
Reverse Voltage	5V
Power dissipation	40mW

Output

Output Current	50mA
Output Voltage	7.0V
Supply Voltage	7.0V
Enable Input Voltage (maximum 500mV above V _{CC})	5.5V
Enable Input Current	5mA
Power Dissipation	85mW

Total Package

Isolation Voltage	3750V _{RMS}
Operating Temperature	-40 to 100 °C
Storage Temperature	-55 to 125 °C
Lead Soldering Temperature (10s)	260°C

ISOCOM COMPONENTS 2004 LTD

Unit 25B, Park View Road West, Park View Industrial Estate
Hartlepool, Cleveland, TS25 1UD, United Kingdom
Tel: +44 (0)1429 863 609 Fax : +44 (0)1429 863 581
e-mail: sales@isocom.co.uk
<http://www.isocom.com>

ISOCOM COMPONENTS ASIA LTD

Hong Kong Office,
Block A, 8/F, Wah Hing Industrial mansion,
36 Tai Yau Street, San Po Kong, Kowloon, Hong Kong.
Tel: +852 2995 9217 Fax : +852 8161 6292
e-mail: sales@isocom.com.hk



ICPL0600 / ICPL0601 / ICPL0611

Truth Table (Positive Logic)

Input	Enable	Output
H	H	L
L	H	H
H	L	H
L	L	H
H	NC	L
L	NC	H

ELECTRICAL CHARACTERISTICS ($T_A = -40^{\circ}\text{C}$ to 85°C unless otherwise specified)

INPUT

Parameter	Symbol	Test Condition	Min	Typ.*	Max	Unit
Forward Voltage	V_F	$I_F = 10\text{mA}$		1.4	1.8	V
Reverse Voltage	V_R	$I_R = 10\mu\text{A}$	5.0			V
Temperature Coefficient of V_F	$\Delta V_F / \Delta T_A$	$I_F = 10\text{mA}$		-1.8		mV/ $^{\circ}\text{C}$
Input Capacitance	C_{IN}	$V_F = 0\text{V}$, $f = 1\text{MHz}$		60		pF

OUTPUT

Parameter	Symbol	Test Condition	Min	Typ.*	Max	Unit
High Level Supply Current	I_{CCH}	$I_F = 0\text{mA}$, $V_E = 0.5\text{V}$, $V_{CC} = 5.5\text{V}$			10	mA
Low Level Supply Current	I_{CCL}	$I_F = 10\text{mA}$, $V_{CC} = 5.5\text{V}$			13	mA
High Level Enable Current	I_{EH}	$V_E = 2.0\text{V}$, $V_{CC} = 5.5\text{V}$			-1.6	mA
Low Level Enable Current	I_{EL}	$V_E = 0.5\text{V}$, $V_{CC} = 5.5\text{V}$			-1.6	mA
High Level Enable Voltage	V_{EH}	$I_F = 10\text{mA}$, $V_{CC} = 5.5\text{V}$	2.0			V
Low Level Enable Voltage	V_{EL}	$I_F = 10\text{mA}$, $V_{CC} = 5.5\text{V}$			0.8	V

* Typical values at $T_A = 25^{\circ}\text{C}$



ICPL0600 / ICPL0601 / ICPL0611

ELECTRICAL CHARACTERISTICS ($T_A = -40^{\circ}\text{C}$ to 85°C unless otherwise specified)

COUPLED

Parameter	Symbol	Test Condition	Min	Typ.*	Max	Unit
High Level Output Current	I_{OH}	$V_{CC} = 5.5\text{V}$, $V_E = 2.0\text{V}$, $V_O = 5.5\text{V}$, $I_F = 250\mu\text{A}$			100	μA
Low Level Output Voltage	V_{OL}	$V_{CC} = 5.5\text{V}$, $V_E = 2.0\text{V}$, $I_F = 5\text{mA}$, $I_{OL} = 13\text{mA}$			0.6	V
Input Threshold Current	I_{FT}	$V_{CC} = 5.5\text{V}$, $V_E = 2.0\text{V}$, $V_O = 0.6\text{V}$, $I_{OL} = 13\text{mA}$			5	mA

Switching Characteristics ($T_A = -40^{\circ}\text{C}$ to 85°C , $V_{CC} = 5\text{V}$, $I_F = 7.5\text{mA}$ unless otherwise specified)

Parameter	Symbol	Test Condition	Min	Typ.*	Max	Unit
Propagation Delay Time to Output High Level	t_{PHL}	$C_L = 15\text{pF}$, $R_L = 350\Omega$, $T_A = 25^{\circ}\text{C}$		35	75	ns
Propagation Delay Time to Output Low level	t_{PLH}	$C_L = 15\text{pF}$, $R_L = 350\Omega$, $T_A = 25^{\circ}\text{C}$		45	75	ns
Pulse Width Distortion	$ t_{PHL} - t_{PLH} $	$C_L = 15\text{pF}$, $R_L = 350\Omega$		10	35	ns
Output Rise Time	t_r	$C_L = 15\text{pF}$, $R_L = 350\Omega$		30	40	ns
Output Fall Time	t_f	$C_L = 15\text{pF}$, $R_L = 350\Omega$		10	20	ns
Enable Propagation Delay Time to Output High Level	t_{ELH}	$I_F = 7.5\text{mA}$, $V_{EL} = 0\text{V}$, $V_{EH} = 3\text{V}$, $C_L = 15\text{pF}$, $R_L = 350\Omega$		30	40	ns
Enable Propagation Delay Time to Output Low Level	t_{EHL}			20	30	ns

* Typical values at $T_A = 25^{\circ}\text{C}$



ICPL0600 / ICPL0601 / ICPL0611

ELECTRICAL CHARACTERISTICS ($T_A = -40^\circ\text{C}$ to 85°C unless otherwise specified)

Switching Characteristics ($T_A = -40^\circ\text{C}$ to 85°C , $V_{CC} = 5\text{V}$, $I_F = 7.5\text{mA}$ unless otherwise specified)

Parameter	Symbol	Test Condition	Min	Typ.*	Max	Unit
Common Mode Transient Immunity at Logic High	CM _H	ICPL0600 (Fig 14) $I_F = 0\text{mA}$, $V_{OH} = 2\text{V}$, $R_L = 350\Omega$, $V_{CM} = 10\text{Vp-p}$, $T_A = 25^\circ\text{C}$				V/ μs
		ICPL0601 (Fig 14) $I_F = 0\text{mA}$, $V_{OH} = 2\text{V}$, $R_L = 350\Omega$, $V_{CM} = 50\text{Vp-p}$, $T_A = 25^\circ\text{C}$	5000			
		ICPL0611 (Fig 14) $I_F = 0\text{mA}$, $V_{OH} = 2\text{V}$, $R_L = 350\Omega$, $V_{CM} = 400\text{Vp-p}$, $T_A = 25^\circ\text{C}$	10000			
		ICPL0611 (Fig 15) $I_F = 0\text{mA}$, $V_{OH} = 2\text{V}$, $R_L = 350\Omega$, $V_{CM} = 400\text{Vp-p}$, $T_A = 25^\circ\text{C}$	15000			
Common Mode Transient Immunity at Logic Low	CM _L	ICPL0600 (Fig 14) $I_F = 7.5\text{mA}$, $V_{OL} = 0.8\text{V}$, $R_L = 350\Omega$, $V_{CM} = 10\text{Vp-p}$, $T_A = 25^\circ\text{C}$				V/ μs
		ICPL0601 (Fig 14) $I_F = 7.5\text{mA}$, $V_{OL} = 0.8\text{V}$, $R_L = 350\Omega$, $V_{CM} = 50\text{Vp-p}$, $T_A = 25^\circ\text{C}$	5000			
		ICPL0611 (Fig 14) $I_F = 7.5\text{mA}$, $V_{OL} = 0.8\text{V}$, $R_L = 350\Omega$, $V_{CM} = 400\text{Vp-p}$, $T_A = 25^\circ\text{C}$	10000			
		ICPL0611 (Fig 15) $I_F = 7.5\text{mA}$, $V_{OL} = 0.8\text{V}$, $R_L = 350\Omega$, $V_{CM} = 400\text{Vp-p}$, $T_A = 25^\circ\text{C}$	15000			

* Typical values at $T_A = 25^\circ\text{C}$



ICPL0600 / ICPL0601 / ICPL0611

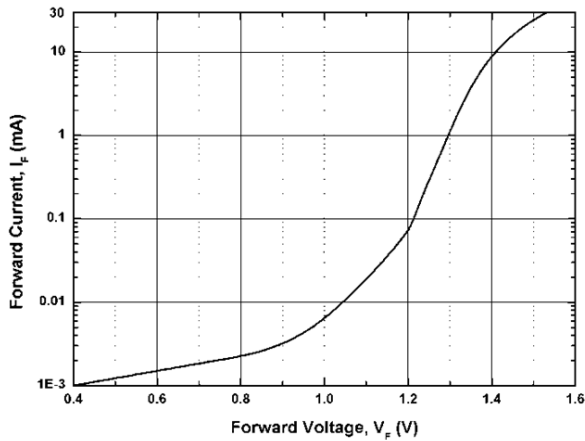

Fig 1 Forward Current vs Forward Voltage

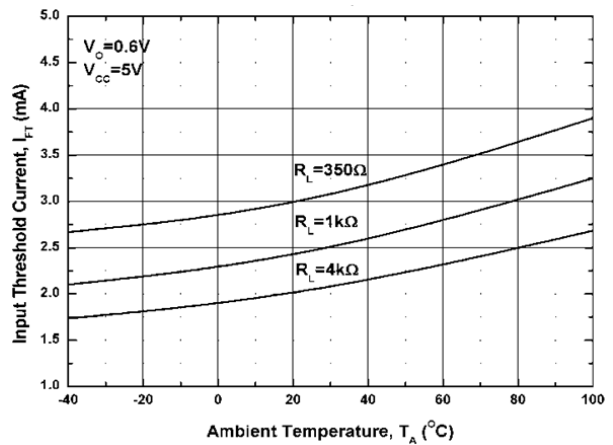

Fig 2 Input Threshold Current vs T_A

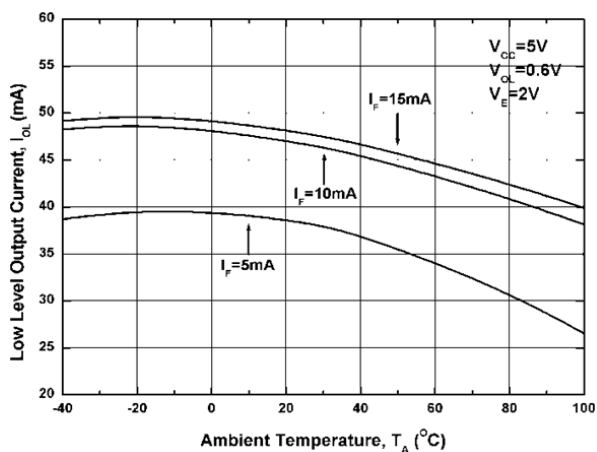

Fig 3 Low Level Output Current vs T_A

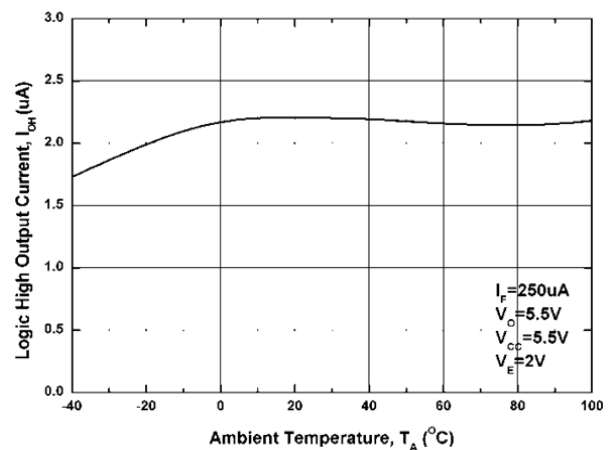

Fig 4 High Level Output Current vs T_A

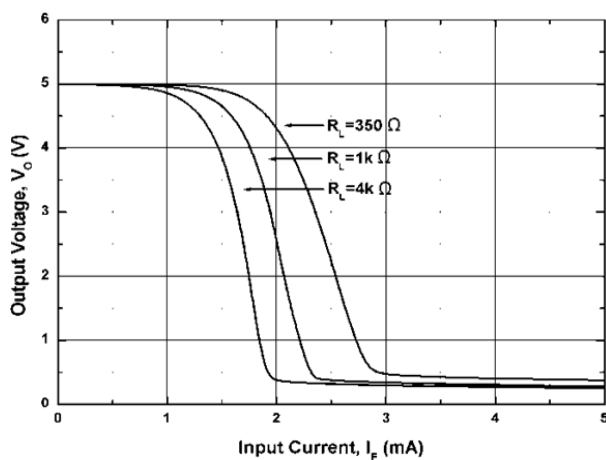

Fig 5 Output Voltage vs Input Forward Current

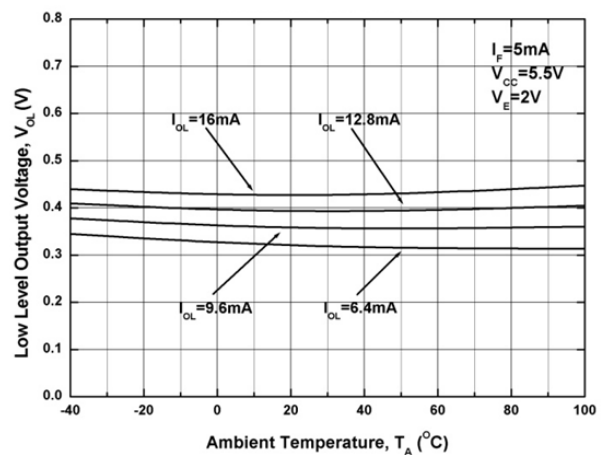

Fig 6 Low Level Output Voltage vs T_A



ICPL0600 / ICPL0601 / ICPL0611

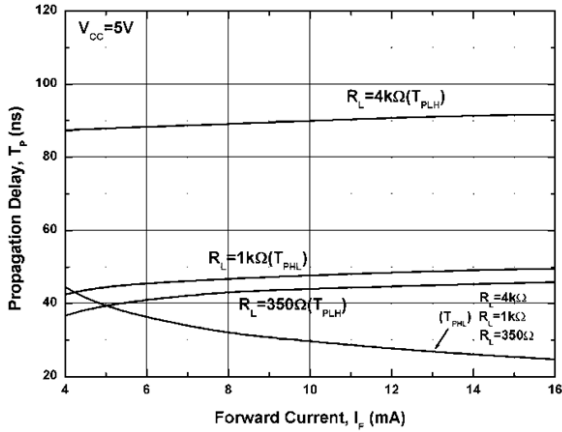

Fig 7 Propagation Delay Time vs Forward Current

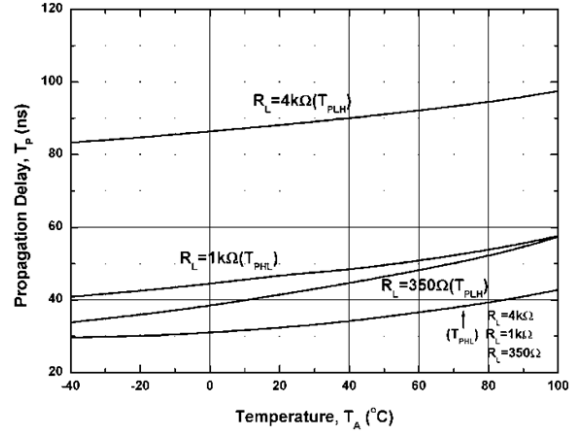

Fig 8 Propagation Delay Time vs T_A

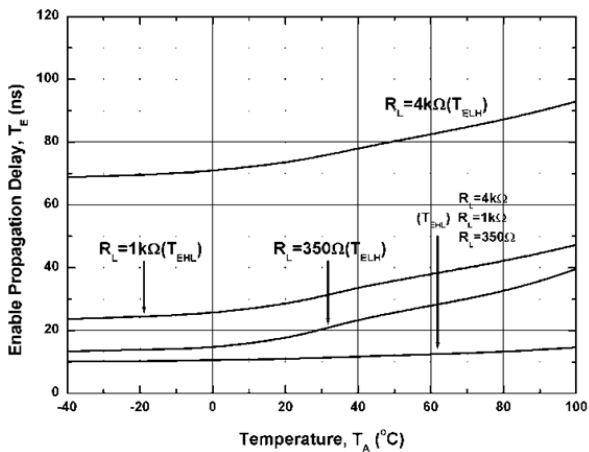

Fig 9 Enable Propagation Delay Time vs T_A

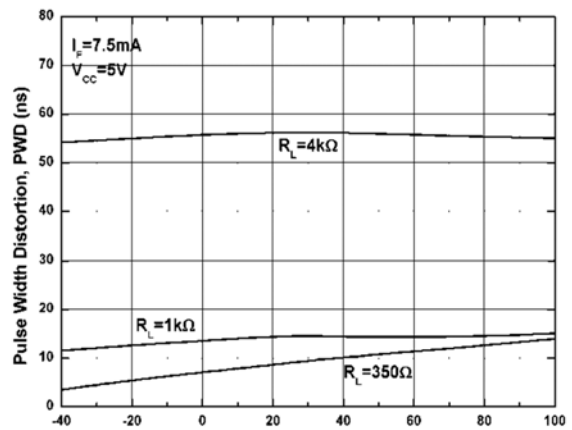

Fig 10 Pulse Width Distortion vs T_A

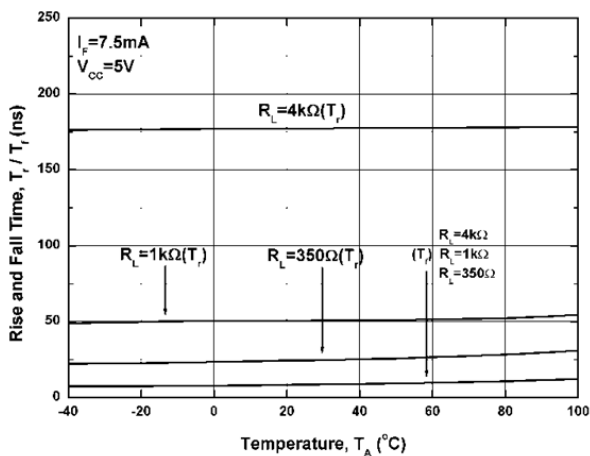

Fig 11 Rise Time / Fall Time vs T_A



ICPL0600 / ICPL0601 / ICPL0611

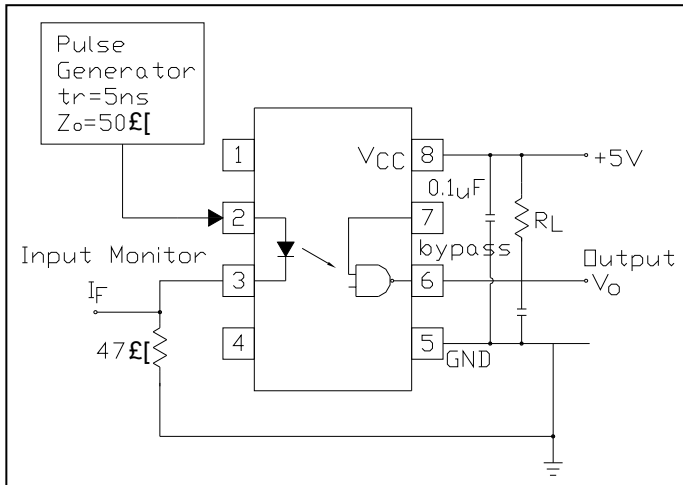

Fig 12 t_{PHL} , t_{PLH} , t_r and t_f Test Circuit

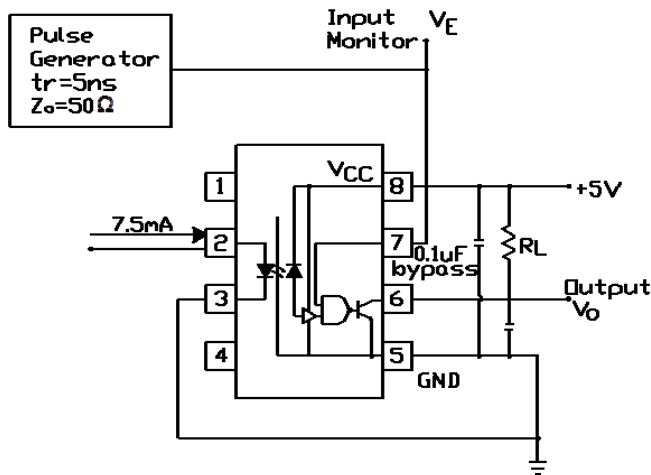
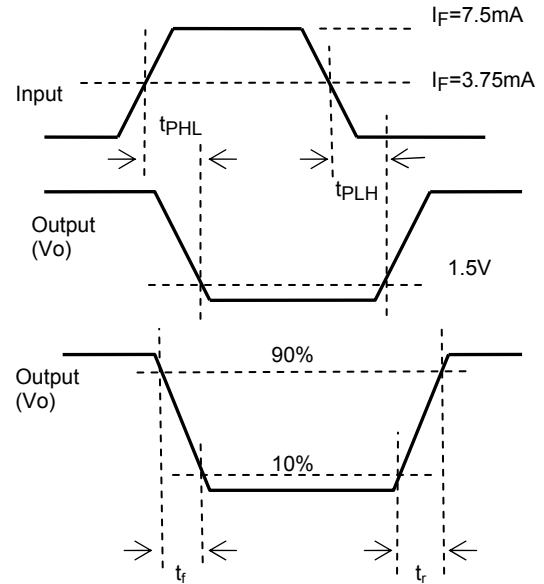
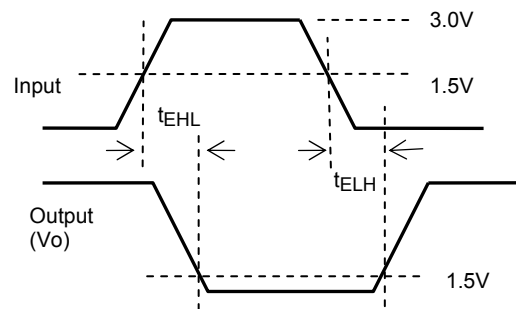

Fig 13 t_{EHL} and t_{ELH} Test Circuit





ICPL0600 / ICPL0601 / ICPL0611

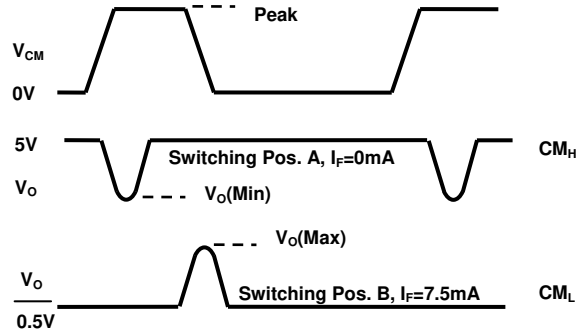
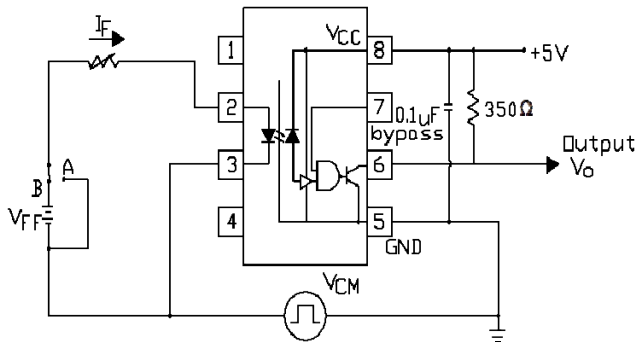

Fig 14 Common Mode Transient Immunity Test Circuit

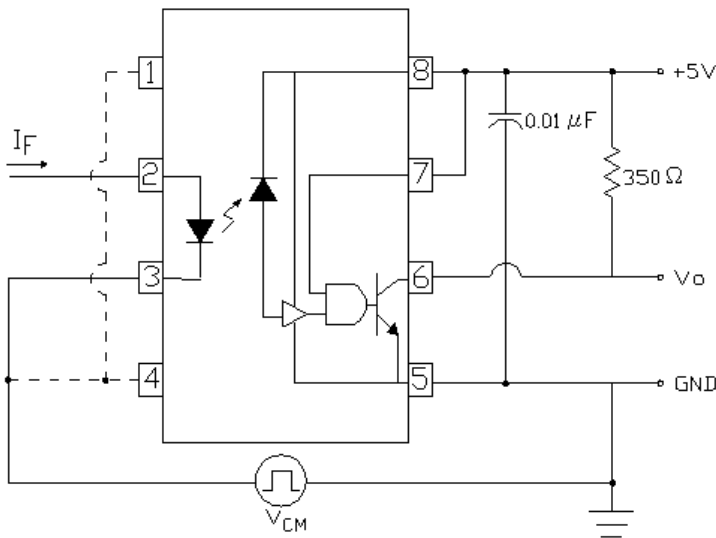

Fig 15 High Common Mode Transient Immunity Test Circuit

Common mode transient immunity in logic high level is the maximum tolerable (positive) dV_{CM}/dt on the leading edge of the common mode pulse signal V_{CM} , to assure that the output will remain in a logic high state (i.e., $V_O > 2.0V$).

Common mode transient immunity in logic low level is the maximum tolerable (negative) dV_{CM}/dt on the trailing edge of the common mode pulse signal, V_{CM} , to assure that the output will remain in a logic low state (i.e., $V_O < 0.8V$).



ICPL0600 / ICPL0601 / ICPL0611

PACKAGE DIMENSIONS (mm)

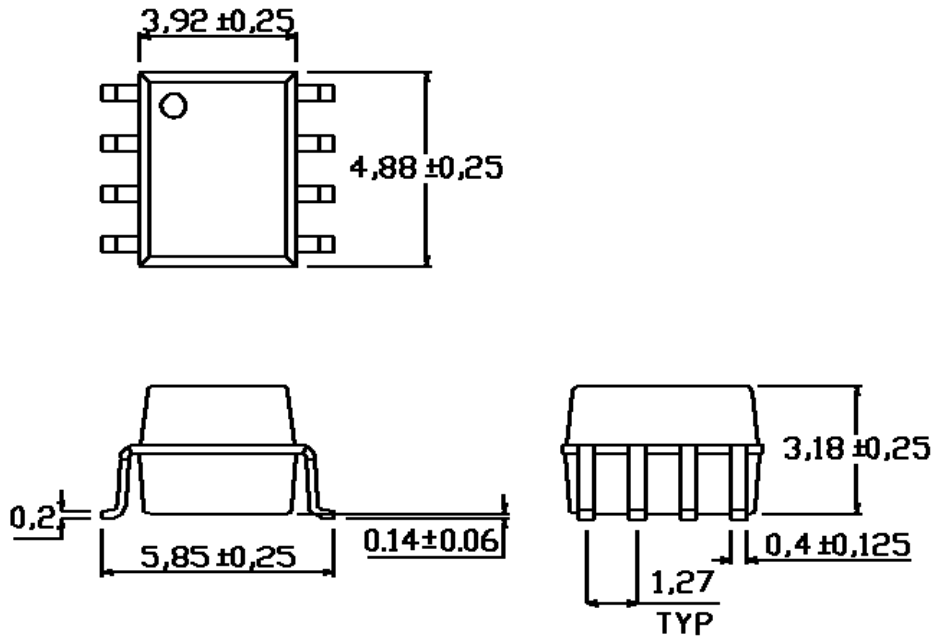

Recommended Solder Pad Layout (mm)

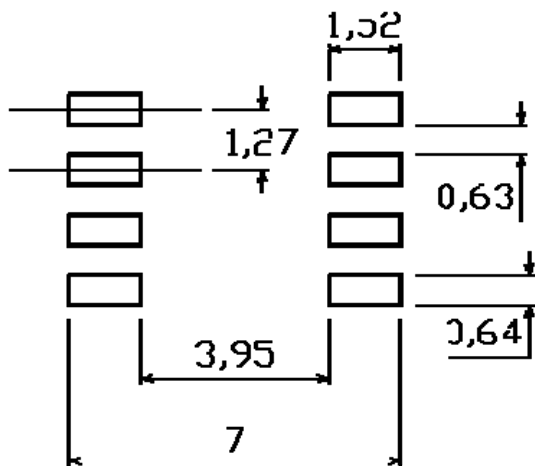



ICPL0600 / ICPL0601 / ICPL0611

Device Marking (Example ICPL0600)

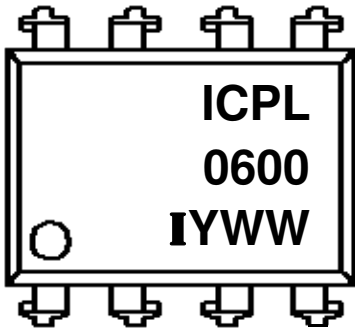

ICPL0600 denotes Device Part Number
Y denotes 1 digit Year code
WW denotes 2 digit Week code
I denotes Isocom

REFLOW SOLDERING TEMPERATURE PROFILE

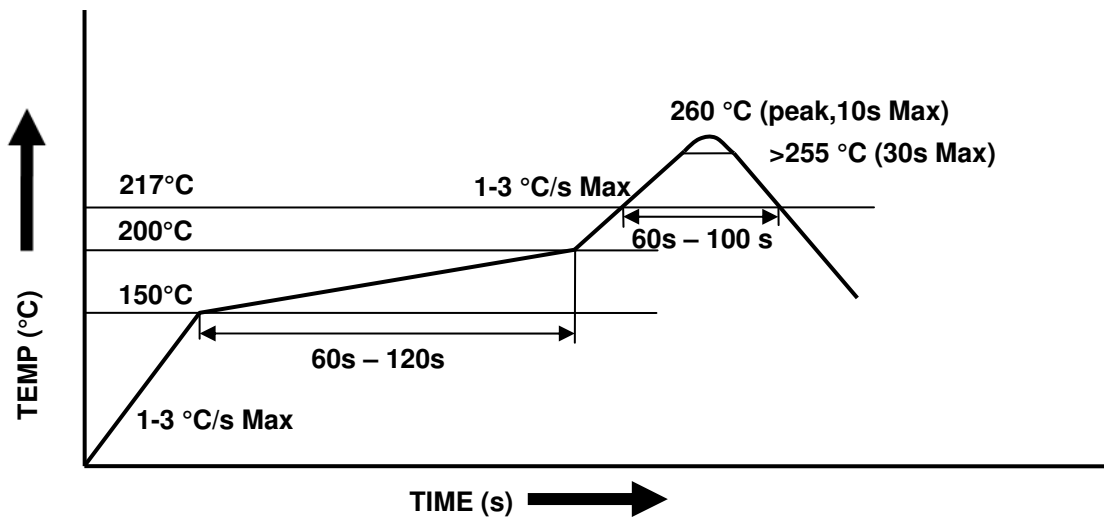



ICPL0600 / ICPL0601 / ICPL0611

Tape and Reel Packaging

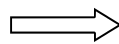
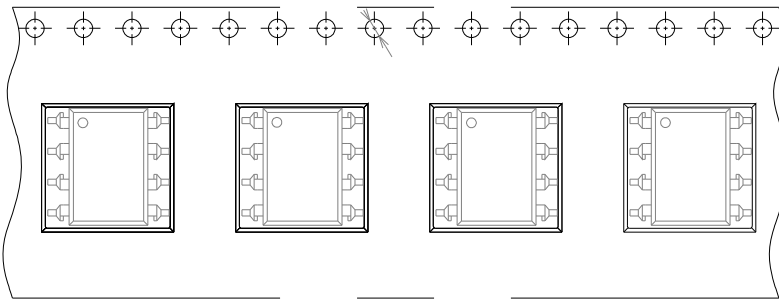

Direction of feed from reel

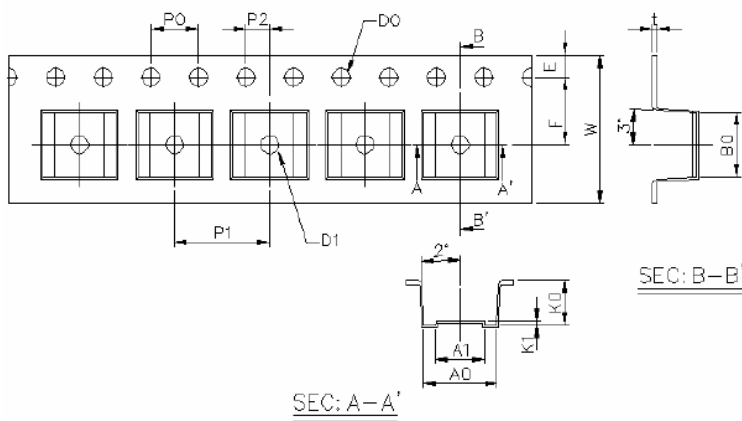

Dimension No.	A0	A1	B0	D0	D1	E	F
Dimension (mm)	6.2±0.1	4.1±0.1	5.28±0.1	1.5±0.1	1.5±0.3	1.75±0.1	5.5±0.1
Dimension No.	Po	P1	P2	t	W	K0	K1
Dimension (mm)	4.0±0.1	8.0±0.1	2.0±0.1	0.4±0.1	12.0 +0.3/-0.1	3.7±0.1	0.3±0.1