

THIS DRAWING IS UNPUBLISHED. RELEASED FOR PUBLICATION
 © COPYRIGHT BY TYCO ELECTRONICS CORPORATION. ALL INTERNATIONAL RIGHTS RESERVED.

DESIGNED FOR USE WITH .141 (RG-402/U) S/R CABLE	
CABLE ENTRY DIAMETER MINIMUM	
CONTACT	.037
HOUSING	.145

REVISONS		DATE	DWN	APVD
P	LTR	DESCRIPTION		
B		REV PER ECO 07-004710	DW	KW
C		REVISED PER ECO-08-030676	AEG	JKO

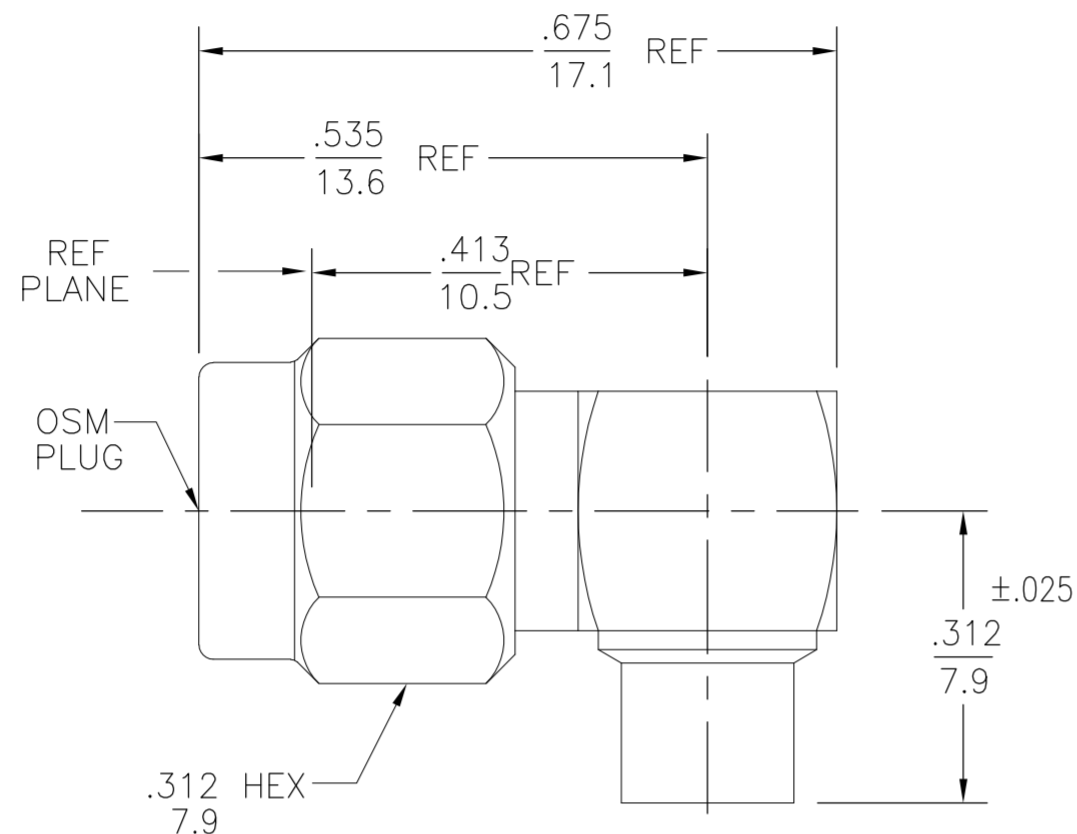

- ① BRASS
- ② STAINLESS STEEL
- ③ BERYLLIUM COPPER
- ④ PTFE
- ⑤ GOLD PLATE
- ⑥ PASSIVATED
- ⑦ SILICONE RUBBER
- ⑧ NICKEL PLATE

ELECTRICAL	MECHANICAL	ENVIRONMENTAL
Nominal Impedance (Ohms) <u>50</u>	Interface Dimensions MIL-STD-348, Fig. 310.1	TEMPERATURE RATING <u>-65°C TO 125°C</u>
Frequency Range (GHz) DC to <u>12</u>	Recommended Mating Torque <u>7-10 Inch-Lbs</u>	Vibration MIL-STD-202, Method 204, Condition D
Volt Rating (VRMS MAX) @ Sea Level <u>500</u>	Mating Characteristics: Insertion (MAX Lbs) <u>N/A</u>	Shock MIL-STD-202, Method 213, Condition I
VSWR <u>1.10 + .010 f GHz</u>	Withdrawal (MIN Oz) <u>N/A</u>	Thermal Shock MIL-STD-202, Method 107, Condition B, EXCEPT HIGH TEMP 115°C
Insertion Loss (dB MAX) <u>.05 √fGHz</u>	Force to Engage and Disengage (In/Lbs MAX) <u>2.0</u>	Moisture Resistance MIL-STD-202, Method 106, Except Vibration
RF Leakage (dB MIN) <u>-60 @ 2 To 3 GHz</u>	Center Contact Captivation Axial (Lbs) <u>6.0</u>	Shall Be Omitted
Dielectric Withstanding Voltage (VRMS MIN) @ Sea Level <u>1500</u>	Cable Retention Radial (In/Oz) <u>4.0</u>	Corrosion - MIL-STD-202, Method 101, Condition B, 5% salt spray
Contact Resistance (Milliohms MAX) Center Contact <u>3.0</u>	Axial Force (Lbs) <u>60</u>	
Outer Contact <u>2.0</u>	Torque (In/Oz) <u>55</u>	
Cable to Housing <u>0.5</u>	Weight (Grams) <u>3.9</u>	
RF High Potential @ Sea Level (VRMS MIN @ 5 MHz) <u>1000</u>		
I.R.(Megohms MIN) <u>5.000</u>		

.XXX = in
XX.X = mm

⑦	③	③ ⑤	④	① ⑧	① ⑤	① ⑤	1051151-3
⑦	③	③ ⑤	④	② ⑥	② ⑤	② ⑤	1051151-1
GASKET	RETAINING RING	CONTACT	DIELECTRIC	COUPLING NUT	HOUSING	CAP	PART NUMBER

THIS DRAWING IS A CONTROLLED DOCUMENT.		DWN JR 8/28/72	Tyco Electronics Corporation Harrisburg, PA 17105-3608	
DIMENSIONS: INCHES		CHK RMF 8/29/72	NAME OSM HIGH FREQUENCY RIGHT ANGLE CABLE PLUG-DIRECT SOLDER ATTACHMENT	
TOLERANCES UNLESS OTHERWISE SPECIFIED:		APVD BWC 8/30/72	SIZE A2 CAGE CODE 00779 DRAWING NO C-1051151	
0 PLC ± -		PRODUCT SPEC -	RESTRICTED TO -	
1 PLC ± -		APPLICATION SPEC -	SCALE 5:1 SHEET 1 of 1 REV C	
2 PLC ± -		WEIGHT -		
3 PLC ± .005		CUSTOMER DRAWING		
4 PLC ± -				
ANGLES ± 1°				
MATERIAL -				
FINISH -				