

EVALUATION KIT MANUAL
FOLLOWS DATA SHEET

MAXIM

Low-Voltage Input, 3V/3.3V/5V/ Adjustable Output, Step-Up DC-DC Converters

General Description

The MAX777L/MAX778L/MAX779L are pulse-skipping DC-DC converters that step up from low-voltage inputs (1V guaranteed). They require only three external components—an inductor (typically 22 μ H) and two capacitors. The MAX777L delivers a 5V output, the MAX778L generates pin-selectable voltages of 3.0V or 3.3V, and the MAX779L output can be adjusted from 2.5V to 6V through an external resistive divider.

The devices include an Active Rectifier™ that eliminates the need for an external catch diode, and permits regulation even when the input is greater than the output. Also, unlike those in other step-up converters, the MAX777L/MAX778L/MAX779L's Active Rectifier™ turns off in the shutdown mode, disconnecting the output from the source. This eliminates the current drain associated with conventional step-up converters when off or in shutdown.

High-frequency operation (up to 150kHz) allows the use of small, surface-mount inductors with values of 10 μ H or less. Supply current is 190 μ A under no load and only 20 μ A in stand-by mode; supply voltage can range from 1V to 4.5V (1 to 3 cells). With a 2V input, the devices typically deliver 200mA at 5V, or 300mA at 3V.

For fully specified devices designed for step-up/step-down applications (where the input can be above or below the output), refer to the MAX877L/MAX878L/MAX879L data sheet.

Applications

Single Battery-Cell (1V), Step-Up Voltage Conversion
Efficient, High-Power Step-Up Regulation from Low Input Voltages
Pagers
Portable Instruments & Hand-Held Terminals
Notebook and Palmtop Computers

Typical Operating Circuit

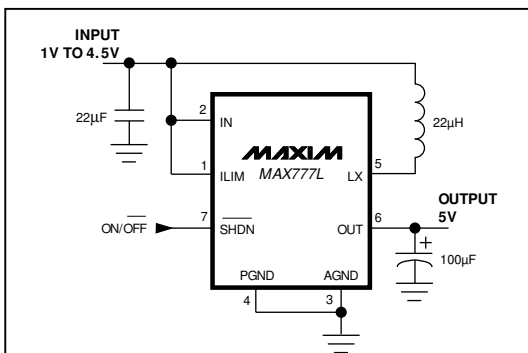

Active Rectifier is a trademark of Maxim Integrated Products.

Features

- ♦ 1V to 4.5V Input Guarantees Start-Up Under Load
- ♦ Up to 210mA Output
- ♦ Load Fully Disconnected in Shutdown
- ♦ 82% Efficiency
- ♦ Output in Regulation with Input Voltage above Output Voltage
- ♦ Internal 1A Power Switch and Active Rectifier
- ♦ Adjustable Current Limit Allows Low-Cost Inductors
- ♦ 190 μ A No Load Supply Current
- ♦ 20 μ A Shutdown Supply Current
- ♦ 3V/3.3V (MAX778L), 5V (MAX777L), and Adjustable (MAX779L) Output Voltage

Ordering Information

PART	TEMP. RANGE	PIN-PACKAGE
MAX777LCPA	0°C to +70°C	8 Plastic DIP
MAX777LCSA	0°C to +70°C	8 SO
MAX777LC/D	0°C to +70°C	Dice*
MAX777LEPA	-40°C to +85°C	8 Plastic DIP
MAX777LESA	-40°C to +85°C	8 SO
MAX777LMJA	-55°C to +125°C	8 CERDIP**

Ordering Information continued at end of data sheet.

* Dice are specified at $T_A = +25^\circ\text{C}$, DC parameters only.

**Contact factory for availability and processing to MIL-STD-883.

Pin Configuration

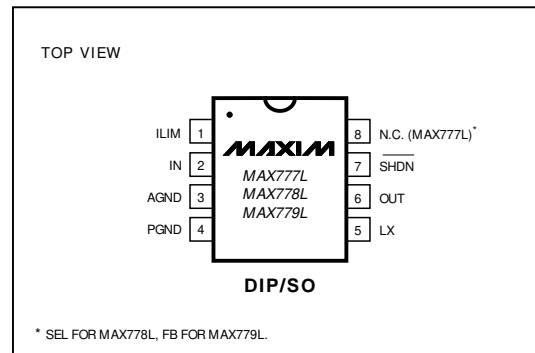

* SEL FOR MAX778L, FB FOR MAX779L.

MAX777L/MAX778L/MAX779L

MAXIM

Maxim Integrated Products 1

For free samples & the latest literature: <http://www.maxim-ic.com>, or phone 1-800-998-8800

Low-Voltage Input, 3V/3.3V/5V/ Adjustable Output, Step-Up DC-DC Converters

ABSOLUTE MAXIMUM RATINGS

Supply Voltage (IN to PGND).....0V to 4.5V	Continuous Power Dissipation (TA = +70°C)
Output Short-Circuit Duration to PGND, AGND (Note 1).....30sec	Plastic DIP (derate 9.09mW/°C above +70°C)727mW
Voltage Applied to:	SO (derate 5.88mW/°C above +70°C)471mW
LX (switch off)-0.3V to 4.5V	CERDIP (derate 8.00mW/°C above +70°C)640mW
(switch on)30sec short to IN or OUT	Operating Temperature Ranges:
OUT, SHDN-0.3V to +7V	MAX77_LC_A0°C to +70°C
FB-0.3V to (OUT + 0.3V)	MAX77_LE_A-40°C to +85°C
AGND to PGND-0.3V, +0.3V	MAX77_LMJA-55°C to +125°C
Reverse Battery Current.....900mA	Storage Temperature Range-65°C to +150°C
	Lead Temperature (soldering, 10sec)+300°C

Note 1: The output may be shorted to ground if the package power dissipation is not exceeded.

Stresses beyond those listed under "Absolute Maximum Ratings" may cause permanent damage to the device. These are stress ratings only, and functional operation of the device at these or any other conditions beyond those indicated in the operational sections of the specifications is not implied. Exposure to absolute maximum rating conditions for extended periods may affect device reliability.

ELECTRICAL CHARACTERISTICS

(VIN = +2.5V, ILOAD = 0mA, L = 22µH, COUT = 100µF, SHDN and ILIM connected to IN, AGND connected to PGND, TA = TMIN to TMAX, typical values are at TA = +25°C, unless otherwise noted.)

PARAMETER	CONDITIONS		MIN	TYP	MAX	UNITS
Minimum Start-Up Voltage	ILOAD < 10mA, TA = +25°C (Note 2)				1	V
Maximum Operating Voltage	(Notes 2, 3)		4.5			V
Output Voltage MAX777L/MAX779L (set to 5V) (Note 6)		MAX777LC/ MAX779LC ILOAD ≤ 30mA, 1.1V ≤ VIN ≤ 4.5V or ILOAD ≤ 140mA, 1.8V ≤ VIN ≤ 4.5V	4.80	5.00	5.20	V
		MAX777LE/ MAX779LE ILOAD ≤ 30mA, 1.2V ≤ VIN ≤ 4.5V or ILOAD ≤ 130mA, 1.8V ≤ VIN ≤ 4.5V				
		MAX777LM/ MAX779LM ILOAD ≤ 25mA, 1.25V ≤ VIN ≤ 4.5V or ILOAD ≤ 120mA, 1.8V ≤ VIN ≤ 4.5V				
Output Voltage MAX778L (Note 6)	SEL = 0V	MAX778LC ILOAD ≤ 50mA, 1.1V ≤ VIN ≤ 3.3V or ILOAD ≤ 210mA, 1.8V ≤ VIN ≤ 3.3V	3.17	3.30	3.43	V
		MAX778LE ILOAD ≤ 50mA, 1.2V ≤ VIN ≤ 3.3V or ILOAD ≤ 200mA, 1.8V ≤ VIN ≤ 3.3V				
		MAX778LM ILOAD ≤ 50mA, 1.25V ≤ VIN ≤ 3.3V or ILOAD ≤ 180mA, 1.8V ≤ VIN ≤ 3.3V				
	SEL = OPEN	MAX778LC ILOAD ≤ 50mA, 1.1V ≤ VIN ≤ 3V or ILOAD ≤ 210mA, 1.8V ≤ VIN ≤ 3V	2.88	3.00	3.12	V
		MAX778LE ILOAD ≤ 50mA, 1.2V ≤ VIN ≤ 3V or ILOAD ≤ 200mA, 1.8V ≤ VIN ≤ 3V				
		MAX778LM ILOAD ≤ 40mA, 1.25V ≤ VIN ≤ 3V or ILOAD ≤ 180mA, 1.8V ≤ VIN ≤ 3V				
Output Voltage Range (MAX779L)	(Note 4)		2.5		6.0	V
Efficiency	ILOAD = 100mA			82		%
No-Load Supply Current	ILOAD = 0mA (switch off)			190	310	µA
Shutdown Supply Current	SHDN = 0V	MAX77_LC, MAX77_LE		20	30	µA
		MAX77_LM		20	35	µA
SHDN Input Current	0V < SHDN < VIN			15	100	nA
	VIN < SHDN < 5V			12	40	µA

Low-Voltage Input, 3V/3.3V/5V/ Adjustable Output, Step-Up DC-DC Converters

ELECTRICAL CHARACTERISTICS (continued)

($V_{IN} = +2.5V$, $I_{LOAD} = 0mA$, $L = 22\mu H$, $C_{OUT} = 100\mu F$, \overline{SHDN} and $ILIM$ connected to IN , $AGND$ connected to $PGND$, $T_A = T_{MIN}$ to T_{MAX} , typical values are at $T_A = +25^\circ C$, unless otherwise noted.)

PARAMETER	CONDITIONS	MIN	TYP	MAX	UNITS
SHDN Threshold	$V_{IN} = 1V$ to $4.5V$	$V_{IN}/2 + 0.25$			V
	$V_{IN} = 2.5V$	1.20		1.6	
SHDN Enable Delay			150		μs
Current Limit			1.0		A
Current-Limit Temperature Coefficient			-0.3		%/ $^\circ C$
Switch Saturation Voltage	$I_{SW} = 400mA$		0.275		V
	$I_{SW} = 600mA$		0.33		
	$I_{SW} = 1000mA$		0.50		
Maximum Switch On Time	$V_{IN} = 2.5V$		4.0		μs
	$V_{IN} = 1.8V$		5.9		
	$V_{IN} = 1V$		12.6		
Minimum Switch Off Time	MAX777L, MAX779L		1.2		μs
	MAX778		2.2		
Rectifier Forward Voltage Drop	$I_{SW} = 400mA$		0.21		V
	$I_{SW} = 600mA$		0.31		
	$I_{SW} = 1000mA$		0.50		
Error-Comparator Trip Point	MAX779L, over operating input voltage (Note 5)	197.5	202.5	207.5	mV
FB Pin Bias Current	MAX779L, $V_{FB} = 0.3V$		10	40	nA
Switch Off Leakage Current			0.1		μA
Rectifier Off Leakage Current			0.1		μA

Note 2: Output in regulation, $V_{OUT} = V_{OUT}(\text{nominal}) \pm 4\%$.

Note 3: At high V_{IN} to V_{OUT} differentials, the maximum load current is limited by the maximum allowable power dissipation in the package (see *Absolute Maximum Ratings*).

Note 4: Minimum value is production tested. Maximum value is guaranteed by design and is not production tested.

Note 5: V_{OUT} is set to a target value of +5V by 0.1% external feedback resistors. V_{OUT} is measured to be $5V \pm 2.5\%$ to guarantee the error comparator trip point.

Note 6: Start-Up guaranteed under these load conditions.

MAX7777L/MAX7778L/MAX7779L

Low-Voltage Input, 3V/3.3V/5V/ Adjustable Output, Step-Up DC-DC Converters

Typical Operating Characteristics

(Typical Operating Circuit, $T_A = +25^\circ\text{C}$, unless otherwise noted).

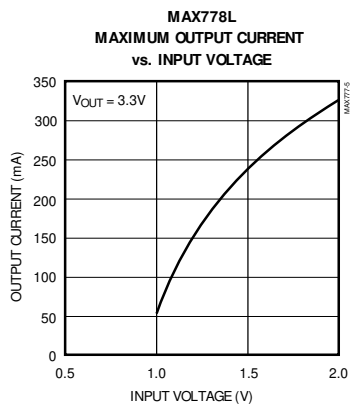
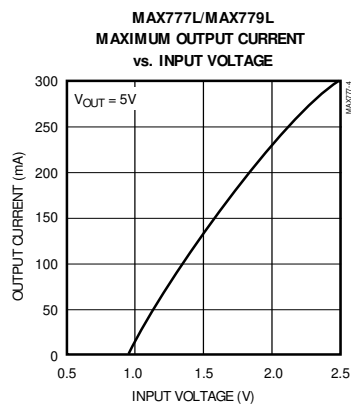
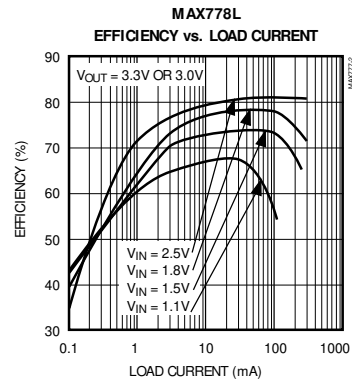
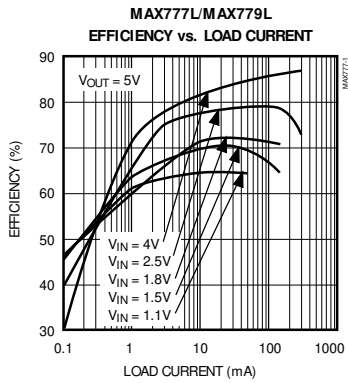
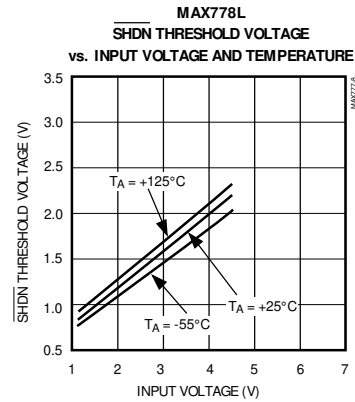
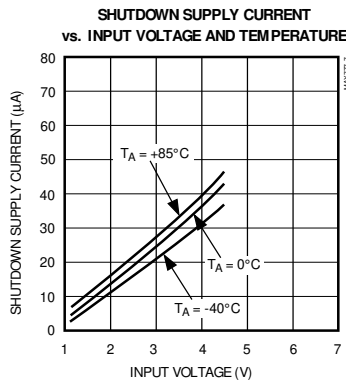
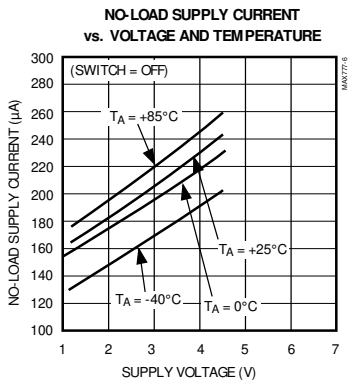

Low-Voltage Input, 3V/3.3V/5V/ Adjustable Output, Step-Up DC-DC Converters

Typical Operating Characteristics (continued)

(Circuit of Figure 1, $T_A = +25^\circ\text{C}$, unless otherwise noted.)

LOAD-TRANSIENT RESPONSE

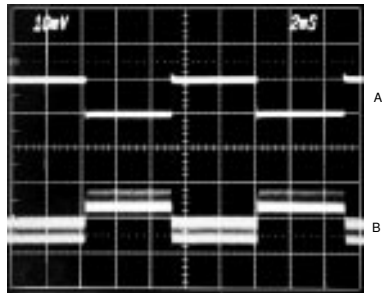

2ms/div

A: I_{OUT} , 200mA/div, 0mA to 200mA
B: V_{OUT} , 50mV/div, AC COUPLED

MAX778L, $V_{OUT} = 3.3\text{V}$, $V_{IN} = 2.5\text{V}$

LINE-TRANSIENT RESPONSE

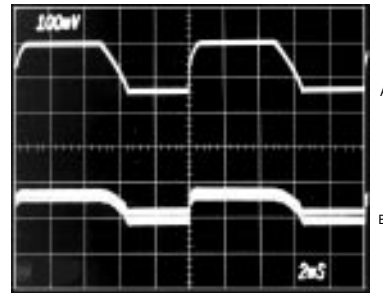

2ms/div

A: V_{IN} , 1V/div, 1.8V to 3.3V
B: V_{OUT} , 100mV/div, AC-COUPLED, $I_{OUT} = 240\text{mA}$

MAX778L, $V_{OUT} = 3.3\text{V}$

SWITCHING WAVEFORMS,
CONTINUOUS CONDUCTION

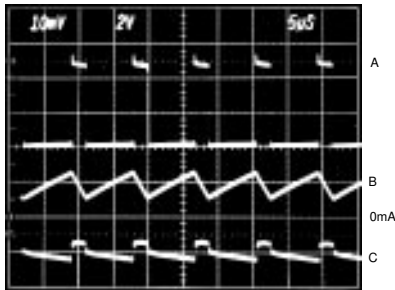

5 μs /div

A: SWITCH VOLTAGE (LX PIN), 2V/div
B: INDUCTOR CURRENT, 0.5A/div
C: OUTPUT VOLTAGE RIPPLE, 50mV/div, AC COUPLED

MAX777L, $V_{IN} = 1.5\text{V}$, $I_{OUT} = 100\text{mA}$

SWITCHING WAVEFORMS,
DISCONTINUOUS CONDUCTION

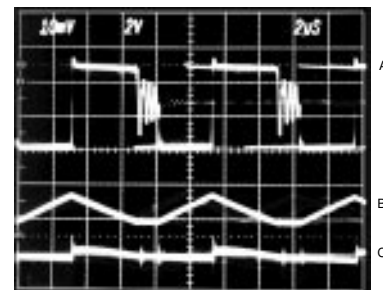

2 μs /div

A: SWITCH VOLTAGE (LX PIN), 2V/div
B: INDUCTOR CURRENT, 0.5A/div
C: OUTPUT VOLTAGE RIPPLE, 50mV/div, AC COUPLED

MAX777L, $V_{IN} = 3\text{V}$, $I_{OUT} = 70\text{mA}$

MAX7777L/MAX778L/MAX779L

Low-Voltage Input, 3V/3.3V/5V/ Adjustable Output, Step-Up DC-DC Converters

Typical Operating Characteristics (continued)

(Circuit of Figure 1, $T_A = +25^\circ\text{C}$, unless otherwise noted.)

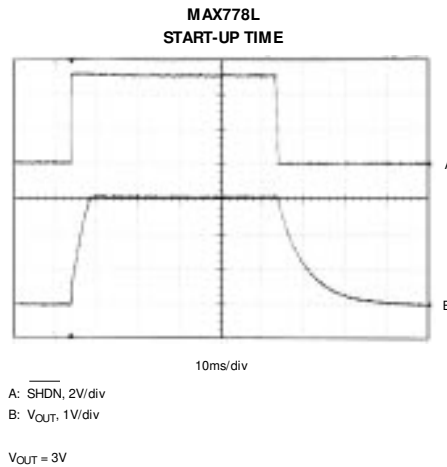

Pin Description

PIN	NAME	FUNCTION
1	ILIM	Sets switch current-limit input. Connect to IN for 1A current limit. A resistor from ILIM to IN sets lower peak inductor currents.
2	IN	Input from battery
3	AGND	Analog ground. Not internally connected to PGND.
4	PGND	Power ground. Must be low impedance; solder directly to ground plane or star ground. Connect to AGND, close to the device.
5	LX	Collector of 1A NPN power switch and emitter of Active Rectifier PNP.
6	OUT	Voltage output. Connect filter capacitor close to pin.
7	$\overline{\text{SHDN}}$	Shutdown input disables power supply when low. Also disconnects load from input. Threshold is set at $V_{IN}/2$.
8	N.C. (MAX777L)	No connect—not internally connected.
	SEL (MAX778L)	Selects the main output voltage. 3.3V when hard-wired to AGND, 3.0V when left open.
	FB (MAX779L)	Feedback input for adjustable-output operation. Connect to an external voltage divider between V_{OUT} and AGND.

Low-Voltage Input, 3V/3.3V/5V/ Adjustable Output, Step-Up DC-DC Converters

MAX7777L/MAX7778L/MAX7779L

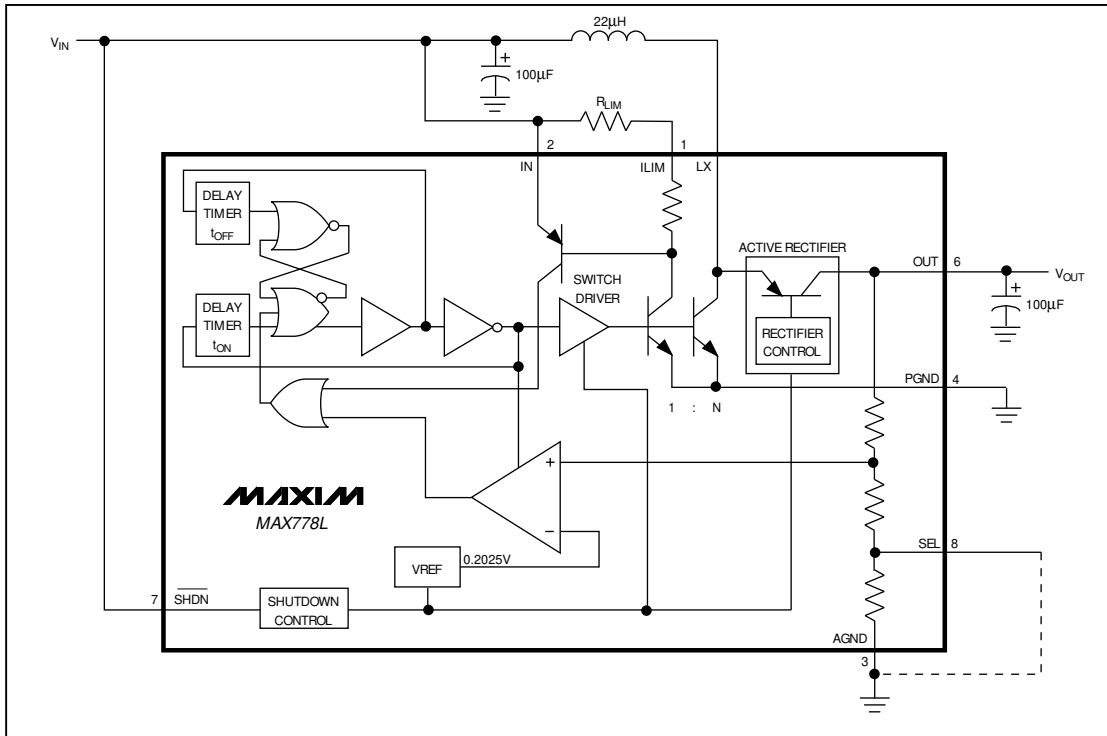

Figure 1. MAX778L Block Diagram

Detailed Description

Operating Principle

The MAX777L/MAX778L/MAX779L combine a switch-mode regulator with an NPN bipolar switch, current limit, precision voltage reference, and active rectifier—all in a single monolithic device. In shutdown mode, the internal rectifier is completely turned off and disconnects the load from the source. Only two external components are required in addition to the input bypass capacitor: a 22µH inductor and a 100µF filter capacitor.

A minimum off-time, current-limited, pulse-frequency-modulation (PFM) control scheme combines the advantages of pulse width modulation (PWM) (high output power and efficiency) with those of a traditional PFM pulse skipper (low quiescent currents).

External conditions (inductor value, load, and input voltage) determine the way the converter operates, as follows:

At light loads, the current through the inductor starts at zero, rises to a peak value, and drops down to zero in each cycle (discontinuous-conduction mode). In this case, the switching frequency is governed by a pair of one-shots that set a maximum on-time inversely proportional to V_{IN} [$t_{ON} = 8.8/(V_{IN} - 0.25)$] and a minimum off-time (1.3µs for MAX777L/MAX779L and 2.3µs for MAX778L). With a 22µH inductor, LX's peak current is about 400mA and is independent of input voltage. Efficiency at light loads is improved because of lower peak currents.

At very light loads, more energy is stored in the coil than is required by the load in each cycle. The converter regulates by skipping entire cycles. Efficiency is typically 65% to 75% in the pulse-skipping mode. Pulse-skipping waveforms can be irregular, and the output waveform contains a low-frequency component. Larger, low equivalent series resistance (ESR) filter capacitors can help reduce the ripple voltage if needed.

Low-Voltage Input, 3V/3.3V/5V/ Adjustable Output, Step-Up DC-DC Converters

At heavy loads above approximately 100mA, the converter enters continuous-conduction mode, where current always flows in the inductor. The switch-on state is controlled cycle-by-cycle by either the maximum t_{ON} time or the switch's preset current limit. As a result, the switch's current rating is not exceeded and the inductor is not saturated. At very heavy loads, the inductor current self-oscillates between this peak current limit and some lower value governed by the minimum off-time, the inductance value, and the input/output differential.

With ILIM shorted to IN, the peak switch current of the internal NPN power switch is set to 1A. The peak switch current can be set to a lower value by connecting a resistor between ILIM and IN (see *Current Limit* section). This enables the use of physically smaller inductors with lower saturation-current ratings. At 1A, the switch voltage drop (V_{SW}) is about 500mV. V_{SW} decreases to about 250mV at 0.1A.

Conventional PWM converters generate constant-frequency switching noise, while this architecture produces variable-frequency switching noise. However, the noise does not exceed the current limit times the filter-capacitor ESR, unlike conventional pulse-skippers.

Step-Down Mode

If the input voltage exceeds the output voltage, the MAX777L/MAX778L/MAX779L behave as "switched" linear regulators. If the output voltage starts to drop, the switch turns on and energy is stored in the coil, as in normal step-up mode. After the switch turns off, the voltage at LX flies high. The active rectifier turns on when LX rises above V_{IN} . As in a linear regulator, the voltage difference between V_{IN} and V_{OUT} appears across the rectifier (actually a PNP transistor) until the current goes to zero and the rectifier turns off. At high V_{IN} to V_{OUT} differentials, the maximum load current is limited by the maximum allowable power dissipation in the package. For fully specified buck/boost converters, refer to the data sheet for the pin-compatible MAX877L/MAX878L/MAX879L.

Active Rectifier

The internal active rectifier of the MAX777L/MAX778L/MAX779L replaces the external Schottky catch diode in normal boost operation. The rectifier consists of a PNP pass transistor and a unique control circuit which, in shutdown mode, entirely disconnects the load from the source. This is a distinct advantage over standard boost topologies, since it prevents battery drain in shutdown.

The active rectifier also acts as a zero-dropout regulator if the input exceeds the regulated output. This allows the MAX777L/MAX778L/MAX779L to act as buck/boost

converters. Useful in battery-powered applications, where the battery voltage may initially exceed the output voltage, the converters will regulate down to the output voltage and seamlessly switch into boost mode as the input drops below the output voltage. The pin-compatible MAX877L/MAX878L/MAX879L are fully specified buck/boost converters with higher specified output currents than the MAX777L/MAX778L/MAX779L.

Shutdown

Shutdown (\overline{SHDN}) is a high-impedance, active-low input. Connect \overline{SHDN} to V_{IN} for normal operation. Keeping \overline{SHDN} at ground holds the converters in shutdown mode. Since the active rectifier is turned off in shutdown mode, the path from input to load is cut, and the output effectively drops to 0V. The supply current in the shutdown state ranges from 4 μ A at $V_{IN} = 1V$ to 50 μ A at $V_{IN} = 4.5V$. The shutdown circuit threshold is set nominally to $V_{IN}/2 + 250mV$. When \overline{SHDN} is below this threshold, the device is shut down and is enabled with \overline{SHDN} above the threshold. When driven from external logic, \overline{SHDN} can be driven to a higher voltage than V_{IN} .

Current Limit

Connecting ILIM to IN sets an LX current limit of 1A. For smaller output power levels that do not require the maximum peak current, the peak inductor current can be reduced to optimize overall efficiency and to allow very small, low-cost coils with lower current ratings. See also the *Inductor Selection* section.

Reduce the MAX777L/MAX778L/MAX779L peak inductor current by connecting a resistor between ILIM and IN. See Figure 2 to select the resistor.

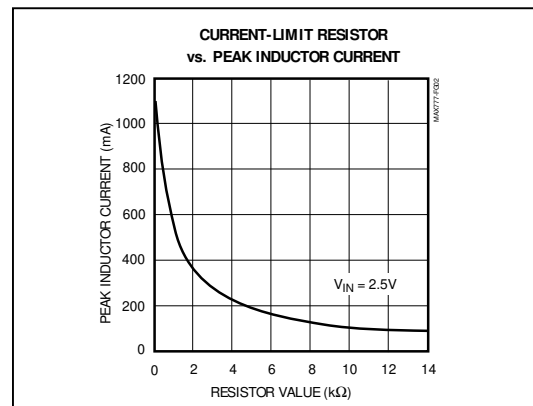

Figure 2. Current-Limit Resistor vs. Current Limit

Low-Voltage Input, 3V/3.3V/5V/ Adjustable Output, Step-Up DC-DC Converters

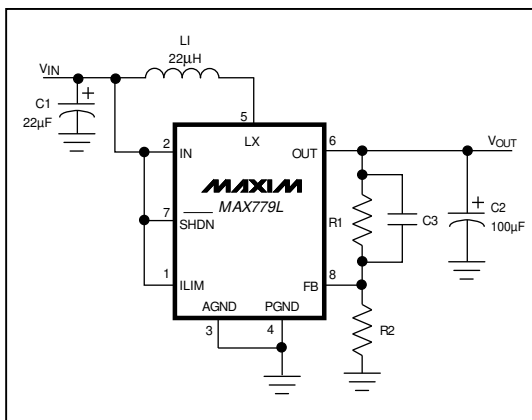

Figure 3. MAX779L Adjustable Voltage

Output Voltage Selection

The output voltage of the MAX777L is fixed at 5V. The MAX778L output voltage can be set to 3V by leaving the SEL pin open. Connect SEL to AGND for 3.3V operation.

The MAX779L's output voltage is set by two resistors, R1 and R2 (Figure 3), which form a voltage divider between the output and the FB pin. The output voltage can be set from 2.5V to 6.0V by the equation:

$$V_{OUT} = (0.2025) [(R1 + R2)/R2]$$

To simplify the resistor selection:

$$R1 = (R2)[(V_{OUT}/0.2025) - 1]$$

Since the input current at FB is 40nA maximum, large values (10kΩ to 50kΩ for R2) can be used with no significant loss of accuracy. For 1% error, the current through R2 should be at least 100 times FB's bias current.

When large values are used for the feedback resistors (R1 > 50kΩ), stray output impedance at FB can add "lag" to the feedback response, destabilizing the regulator and creating a larger ripple at the output. Lead lengths and circuit board traces at the FB node should be kept short. Reduce ripple by adding a "lead" compensation capacitor (C3, 100pF to 50nF) in parallel with R1.

Applications Information

The *Typical Operating Circuit* shows a MAX777L step-up application circuit. This circuit starts up and operates with inputs ranging from 1.0V to 4.5V. Start-up time is a function of the load, typically less than 5ms. Output current capability is a function of the input voltage. See *Typical Operating Characteristics*.

Inductor Selection

The 22µH inductor shown in the *Typical Operating Circuit* is sufficient for most MAX777L/MAX778L/MAX779L designs. Other inductor values ranging from 10µH to 47µH are also suitable. The inductor should have a **saturation rating** equal to or greater than the peak switch-current limit, which is 1A without an external current limit (ILIM connected to IN). It is acceptable to operate the inductor at 120% of its saturation rating; however, this will reduce efficiency. For highest efficiency, use an inductor with a low **DC resistance**, preferably under 0.2Ω. Table 1 lists suggested inductor suppliers.

Capacitor Selection

The 100µF, 10V surface-mount tantalum (SMT) output capacitor shown in the *Typical Operating Circuit* will provide a 20mV output ripple or less, stepping up from 2V to 3.3V at 200mA. Smaller capacitors, down to 10µF, are acceptable for light loads or in applications that tolerate higher output ripple. The input capacitor may be omitted if the input lead length is less than 2 inches (5cm) or if the loads are small.

The primary factor in selecting both the output and input filter capacitor is low ESR. The ESR of both bypass and filter capacitors affects efficiency. Optimize performance by increasing filter capacitors or using specialized low-ESR capacitors. The smallest low-ESR SMT tantalum capacitors currently available are Sprague 595D or 695D series. Sanyo OS-CON organic semiconductor through-hole capacitors also exhibit very low ESR, are rated for the wide temperature range, and are particularly useful for operation at cold temperatures. Table 1 lists suggested capacitor suppliers.

Layout

The MAX777L/MAX778L/MAX779L's high peak currents and high-frequency operation make PC layout important for minimum ground bounce and noise. Locate input bypass and output filter capacitors close to the device pins. All connections to the FB pin (MAX779L) should also be kept as short as possible. A ground plane is recommended. Solder AGND (pin 3) and PGND (pin 4), directly to the ground plane. Refer to the MAX777L/MAX778L/MAX779L evaluation kit (EV kit) manual for a suggested surface-mount layout.

MAX7777L/MAX7778L/MAX7779L

Low-Voltage Input, 3V/3.3V/5V/ Adjustable Output, Step-Up DC-DC Converters

MAX777L/MAX778L/MAX779L

Table 1. Component Suppliers

PRODUCTION METHOD	INDUCTORS		CAPACITORS
Surface Mount	Sumida CD54-220 (22 μ H)		Sprague 595D Sprague 695D Matsuo 267 series AVX TPS series
Miniature Through-Hole	Murata-Erie LQHYN1501K04M00-D5 (15 μ H)		
	Coiltronics CTX20-1		
Miniature Through-Hole	Sumida RCH654-220		Sanyo OS-CON low-ESR organic semiconductor
Low-Cost Through-Hole	Coilcraft PCH-27-223		Nichicon PL series low-ESR electrolytic United Chemi-Con, LXF series
AVX	USA:	(803) 946-0690 (800) 282-4975, FAX (803) 626-3123	
Coiltronics	USA:	(561) 241-7876, FAX (561) 241-9339	
Matsuo	USA:	(714) 969-2491, FAX (714) 960-6492	
Murata-Erie	USA:	(814) 237-1431 (800) 831-9172, FAX (814) 238-0490	
Nichicon	USA:	(847) 843-7500	
Sanyo	USA:	(619) 661-6835, FAX (847) 843-2798	
	Japan:	(81) 7-2070-6306, FAX (81) 7-2070-1174	
Sprague	USA:	(603) 224-1961, FAX (603) 224-1430	
Sumida	USA:	(847) 956-0666, FAX (847) 956-0702	
	Japan:	(81) 3-3607-5111, FAX (81) 3-3607-5144	
United Chemi-Con	USA:	(714) 255-9500, FAX (714) 255-9400	

Low-Voltage Input, 3V/3.3V/5V/ Adjustable Output, Step-Up DC-DC Converters

Ordering Information (continued)

PART	TEMP. RANGE	PIN-PACKAGE
MAX778LCPA	0°C to +70°C	8 Plastic DIP
MAX778LCSA	0°C to +70°C	8 SO
MAX778LC/D	0°C to +70°C	Dice*
MAX778LEPA	-40°C to +85°C	8 Plastic DIP
MAX778LESA	-40°C to +85°C	8 SO
MAX778LMJA	-55°C to +125°C	8 CERDIP**
MAX779LCPA	0°C to +70°C	8 Plastic DIP
MAX779LCSA	0°C to +70°C	8 SO
MAX779LC/D	0°C to +70°C	Dice*
MAX779LEPA	-40°C to +85°C	8 Plastic DIP
MAX779LESA	-40°C to +85°C	8 SO
MAX779LMJA	-55°C to +125°C	8 CERDIP**

* Dice are specified at $T_A = +25^\circ\text{C}$, DC parameters only.

**Contact factory for availability and processing to MIL-STD-883.

Chip Topography

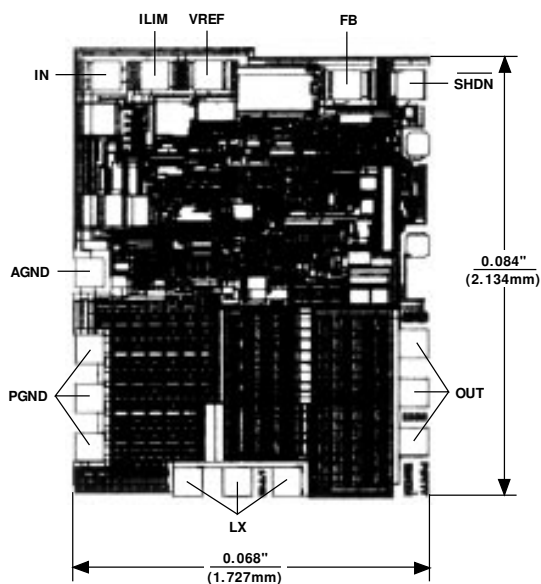

TRANSISTOR COUNT: 170;
SUBSTRATE CONNECTED TO AGND.

MAX7777L/MAX778L/MAX779L

Low-Voltage Input, 3V/3.3V/5V/ Adjustable Output, Step-Up DC-DC Converters

Package Information

**Plastic DIP
PLASTIC
DUAL-IN-LINE
PACKAGE
(0.300 in.)**

DIM	INCHES		MILLIMETERS	
	MIN	MAX	MIN	MAX
A	—	0.200	—	5.08
A1	0.015	—	0.38	—
A2	0.125	0.175	3.18	4.45
A3	0.055	0.080	1.40	2.03
B	0.016	0.022	0.41	0.56
B1	0.045	0.065	1.14	1.65
C	0.008	0.012	0.20	0.30
D1	0.005	0.080	0.13	2.03
E	0.300	0.325	7.62	8.26
E1	0.240	0.310	6.10	7.87
e	0.100	—	2.54	—
eA	0.300	—	7.62	—
eB	—	0.400	—	10.16
L	0.115	0.150	2.92	3.81

PKG.	DIM	PINS	INCHES		MILLIMETERS	
			MIN	MAX	MIN	MAX
P	D	8	0.348	0.390	8.84	9.91
P	D	14	0.735	0.765	18.67	19.43
P	D	16	0.745	0.765	18.92	19.43
P	D	18	0.885	0.915	22.48	23.24
P	D	20	1.015	1.045	25.78	26.54
N	D	24	1.14	1.265	28.96	32.13

21-0043A

**Narrow SO
SMALL-OUTLINE
PACKAGE
(0.150 in.)**

DIM	INCHES		MILLIMETERS	
	MIN	MAX	MIN	MAX
A	0.053	0.069	1.35	1.75
A1	0.004	0.010	0.10	0.25
B	0.014	0.019	0.35	0.49
C	0.007	0.010	0.19	0.25
E	0.150	0.157	3.80	4.00
e	0.050		1.27	
H	0.228	0.244	5.80	6.20
L	0.016	0.050	0.40	1.27

DIM	PINS	INCHES		MILLIMETERS	
		MIN	MAX	MIN	MAX
D	8	0.189	0.197	4.80	5.00
D	14	0.337	0.344	8.55	8.75
D	16	0.386	0.394	9.80	10.00

21-0041A