

THIS DRAWING IS UNPUBLISHED. RELEASED FOR PUBLICATION
 © COPYRIGHT BY TYCO ELECTRONICS CORPORATION. ALL RIGHTS RESERVED.

LOC		DIST		REVISIONS			
P	LTR	DESCRIPTION		DATE	DWN	APVD	
	C2	REVISED PER ECO-07-008164		15AUG07	JDP	CWR	

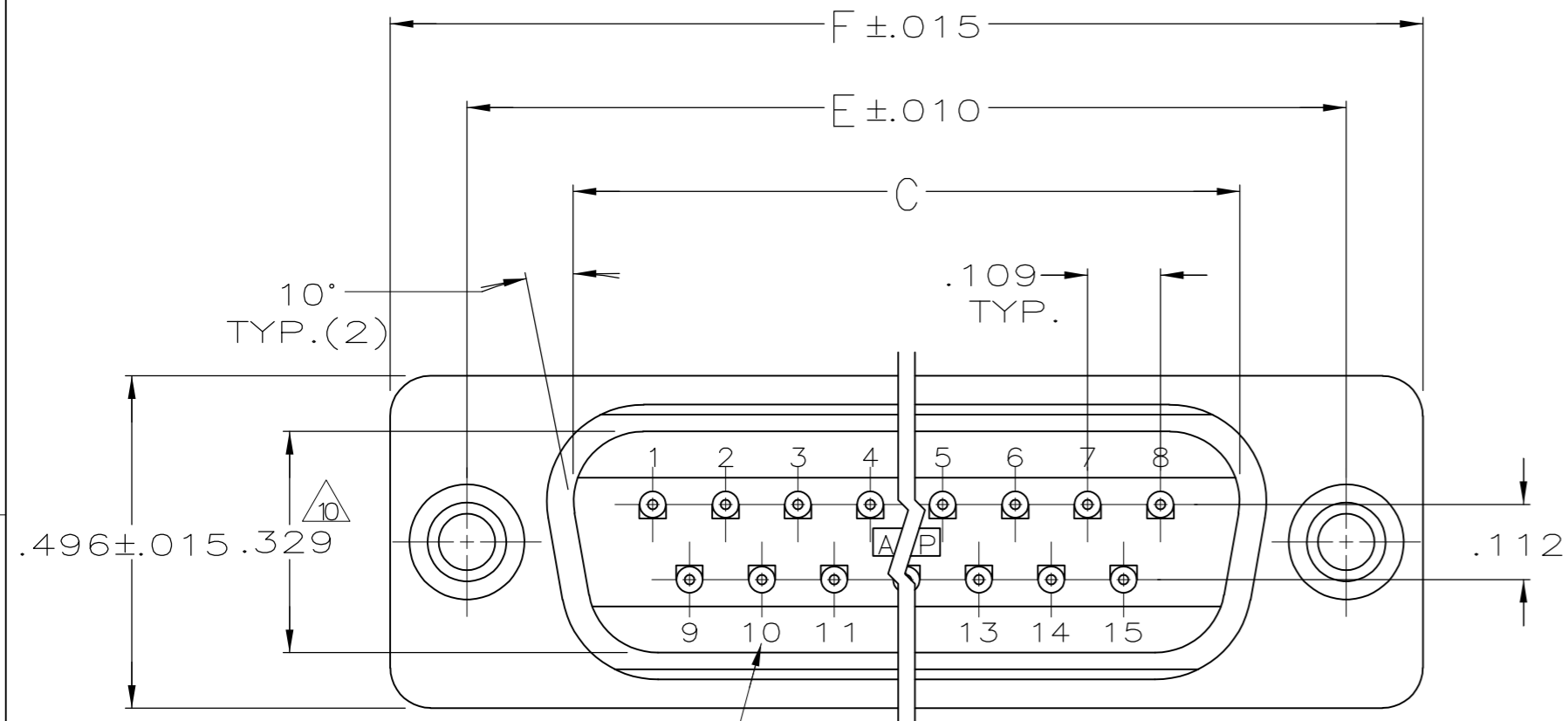

RAISED CAVITY IDENTIFICATION (15 POSITION SHOWN)

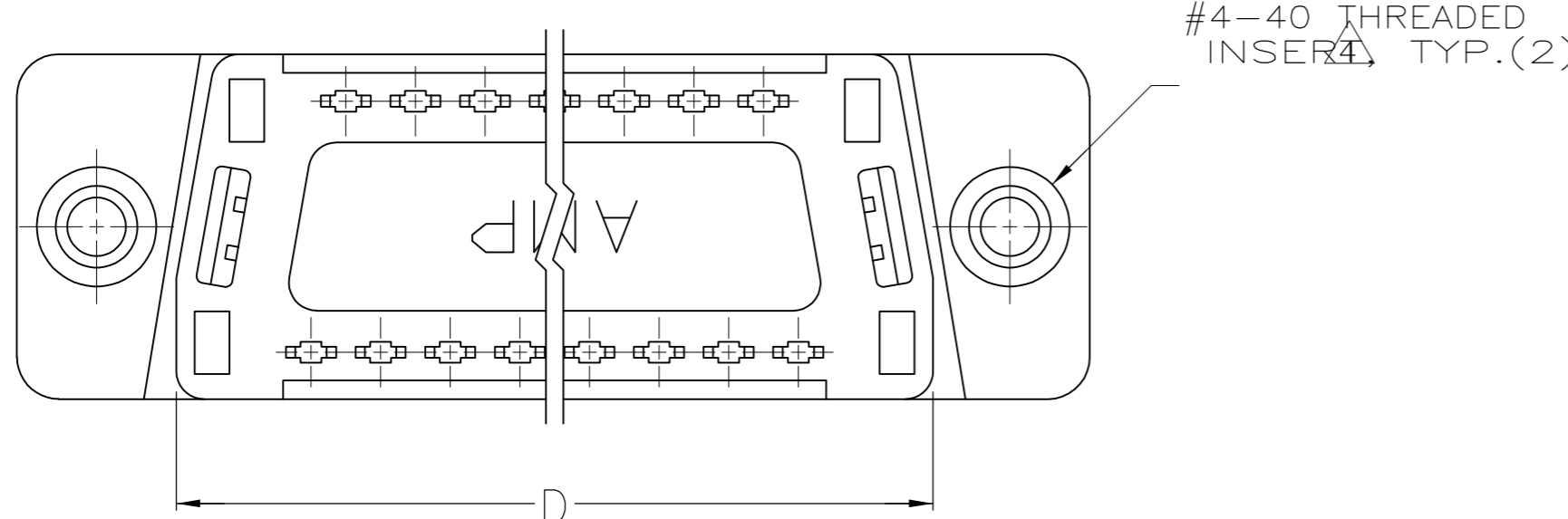
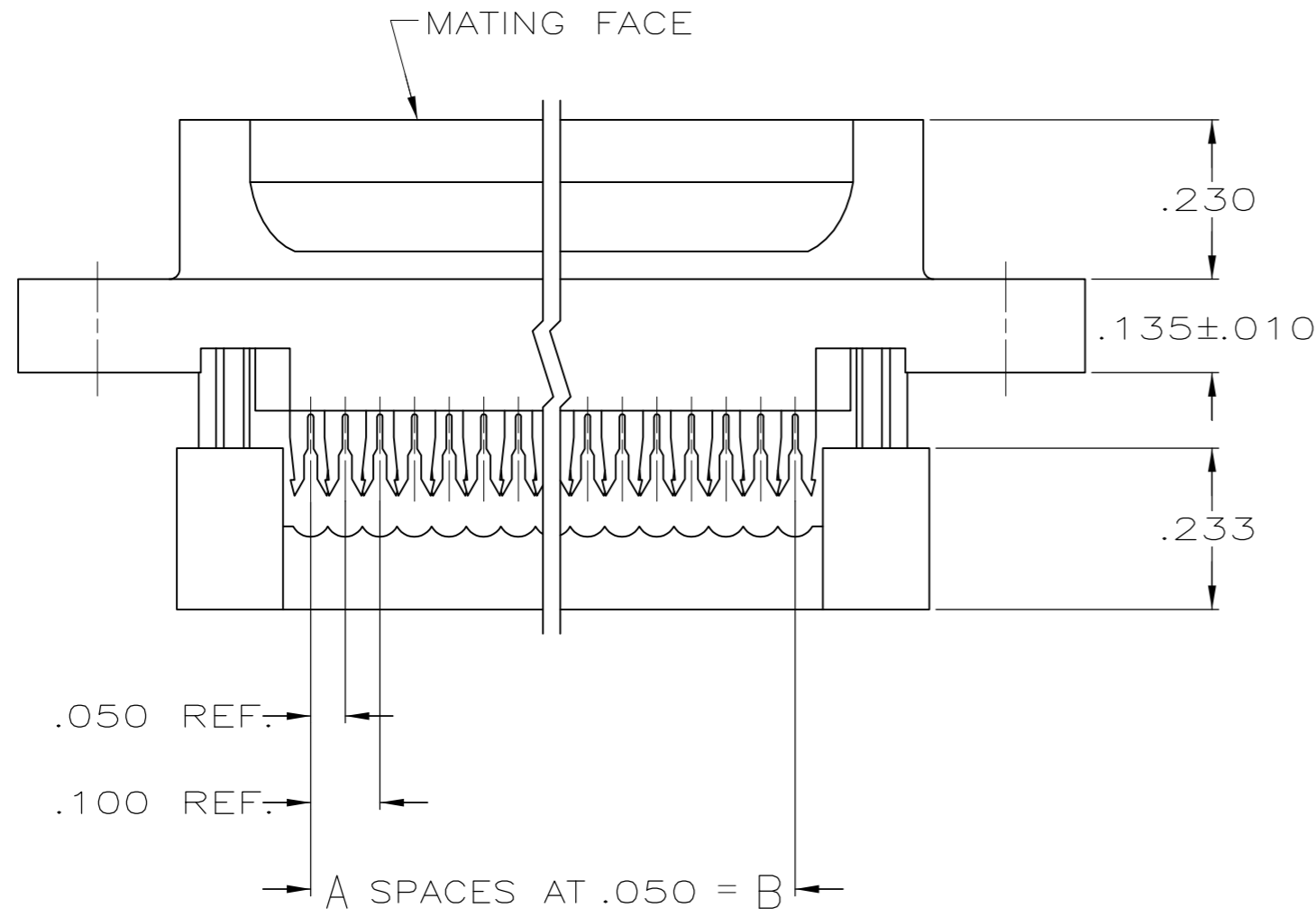

- CONNECTORS COMPLY WITH AMP SPEC. 108-40,012 AND MATE WITH ANY SAME NUMBER POSITION PLUG CONNECTOR IN AMPLIMITE SERIES.
- CONNECTOR DESIGNED FOR 28 AND 26 AWG STRANDED AND SOLID CONDUCTOR RIBBON CABLE ON .050 ϕ .
- DIMENSION APPLIES TO TERMINATED CONNECTOR.
- INSERTS WILL WITHSTAND 6 IN. LBS. TORQUE AND 50 LBS. PULL OUT FORCE FROM MATING FACE SIDE.
- MOLDED PARTS: FLAME RETARDANT 94V-0 RATED THERMOPLASTIC; COLOR: BLACK.
- CONTACTS: PHOS. BRONZE PER QQ-B-750.
- INSERTS: BRASS PER MIL-C-50.
- GOLD PLATING PER MIL-G-45204, BRIGHT TIN PLATING PER MIL-T-10727 (NOT TIN LEAD), NICKEL PLATING PER QQ-N-290.
- CONTACTS: .000030 GOLD ON MATING END, .000100-.000200 BRIGHT TIN OR BRIGHT TIN LEAD ON TERMINATION END, ALL OVER .000050 NICKEL ON ENTIRE CONTACT.
- DIMENSION APPLIES TO BASE OF SHROUD.
- ADVANCED PART NUMBER, NOT PRODUCTION TOOLED.

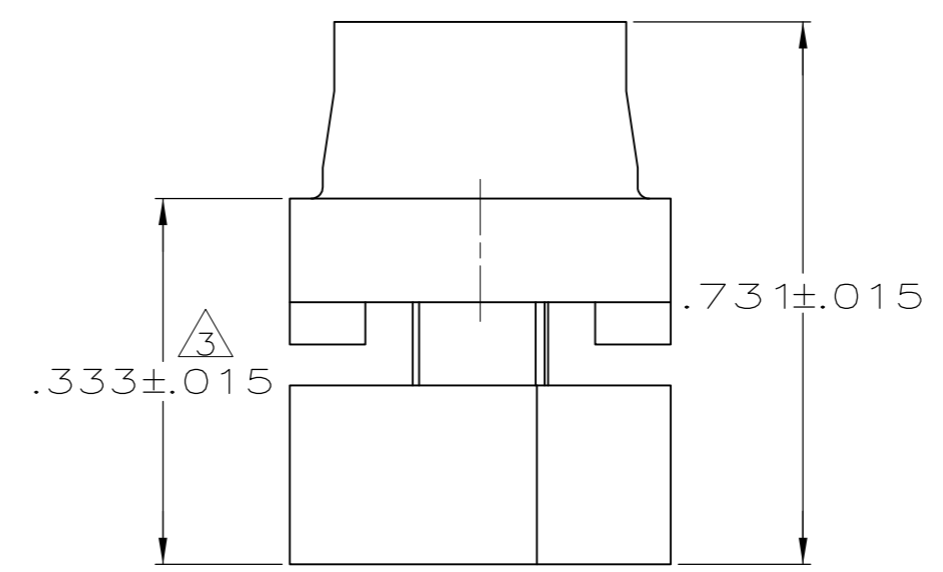

	1.764	1.526	1.287	1.140	.900	18	19	747053-5
OBSOLETE	1.216	.984	.759	.666	.400	8	9	747053-4
OBSOLETE	1.541	1.312	1.087	.994	.700	14	15	747053-3
OBSOLETE	2.090	1.852	1.623	1.534	1.200	24	25	747053-2
OBSOLETE	2.732	2.500	2.275	2.183	1.800	36	37	747053-1
	F	E	D	C	B	A	NO.OF POS.	PART NUMBER

THIS DRAWING IS A CONTROLLED DOCUMENT.

DWN	J. GERACE	01NOV82
CHK	J. GERACE	01NOV82
APVD	R. LEGGETT	05NOV82
PRODUCT SPEC	-	
APPLICATION SPEC	-	
WEIGHT	-	-
CUSTOMER DRAWING	-	

Tyco Electronics Tyco Electronics Corporation
Harrisburg, PA 17105-3608

NAME: PLUG ASSEMBLY, LOW PROFILE HDF, WITH PRE-ASSEMBLED COVER AND THREADED INSERTS

SIZE	CAGE CODE	DRAWING NO	RESTRICTED TO
A2	00779	C=747053	-

SCALE: - SHEET: 1 of 1 REV: C2