

XC74WL4066SR

ETR1326_001

CMOS Logic

■ GENERAL DESCRIPTION

XC74WL4066SR is dual analog switch manufactured using silicon gate CMOS processes. The small supply current, which is one of the features of the CMOS logic, gives way to high speed operations which enables LS-TTL.

With wave forming buffers connected internally, stabilized output can be achieved as the series offers high noise immunity.

As the series is integrated into a mini molded, MSOP-8B package, high density mounting is possible.

■ APPLICATIONS

- Palmtops
- Digital equipment

■ FEATURES

High Speed Operations : $t_{pd} = 1.5\text{ns}$ (TYP.) ($V_{CC}=5\text{V}$)

Operating Voltage Range : $2\text{V} \sim 5.5\text{V}$

Low Power Consumption : $2\mu\text{A}$ (MAX.)@ $T_a=25^\circ\text{C}$

Low ON Resistance : 12Ω (TYP.)

CMOS Logic Dual Analog Switch

Small Package : MSOP-8B

■ PIN CONFIGURATION

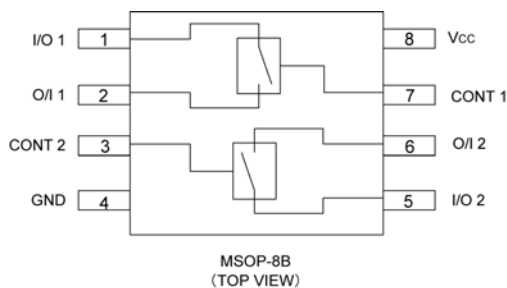

■ FUNCTIONS

CONTROL	STATE
L	OFF
H	ON

H=High level

L=Low level

■ LOGIC DIAGRAM

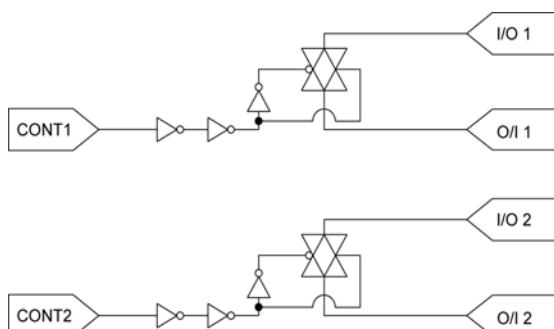

■ ABSOLUTE MAXIMUM RATINGS

Ta=-40°C~85°C

PARAMETER	SYMBOL	RATINGS	UNITS
Supply Voltage	VCC	-0.5~+6.0	V
Input Voltage	VCONT	-0.5~+6.0	V
Output Voltage	Vi/o	-0.5~VCC+0.5	V
Input Diode Current	IiK	-20	mA
Output Diode Current	IoK	± 20	mA
Switch Output Current	Ii/O	± 25	mA
VCC,GND Current	ICC,IGND	± 50	mA
Power Dissipation (Ta = 25°C)	Pd	300	mW
Storage Temperature Range	Tstg	-65~+150	°C

Note : Voltage is all ground standardized.

■ RECOMMENDED OPERATING CONDITIONS

PARAMETER	SYMBOL	CONDITIONS	UNITS
Supply Voltage	VCC	2~5.5	V
Input Voltage	VCONT	0~5.5	V
Output Voltage	Vi/o	0~VCC	V
Operating Temperature Range	Topr	-40~+85	°C
Input Rise and Fall Time	tr,tf	0~200 (VCC=3.3V)	ns
		0~100 (VCC=5V)	

■ DC ELECTRICAL CHARACTERISTICS

PARAMETER	SYMBOL	VCC(V)	CONDITIONS	Ta=25°C			Ta=-40°C~85°C		UNITS
				MIN.	TYP.	MAX.	MIN.	MAX.	
High Level Control Input Voltage	VIH	2.0		1.50	-	-	1.50	-	V
		3.0		2.10	-	-	2.10	-	
		5.5		3.85	-	-	3.85	-	
Low Level Control Input Voltage	VIL	2.0		-	-	0.50	-	0.50	V
		3.0		-	-	0.90	-	0.90	
		5.5		-	-	1.65	-	1.65	
Peak ON Resistance	RONmax	2.0	VCONT=VIH	-	130	350	-	550	Ω
		3.0	VIN=0~VCC	-	22	50	-	65	
		4.5	IIN/OUT=1mA	-	12	25	-	35	
ON Resistance	RON(1)	2.0	VCONT=VIH	-	23	50	-	65	Ω
		3.0	VIN=GND or VCC	-	14	30	-	40	
		4.5	IIN/OUT=1mA	-	10	20	-	25	
Switch ON Resistance Differential	△ RON	2.0	VCONT=VIH	-	13	35	-	55	Ω
		3.0	VIN=0~VCC	-	3	6	-	8	
		4.5	IIN/OUT=1mA	-	2	4	-	6	
Power Off Leak Current	IS(OFF)	5.5	VCONT=VIL, VIN=VCC, VOUT=GND	-	-	± 0.1	-	± 1.0	μ A
Power On Leak Current	IS(ON)	5.5	VCONT=VIH, VIN=VCC, OR GND	-	-	± 0.1	-	± 1.0	μ A
Control Input Current	ICONT	0~5.5	VIN=VCC or GND	-	-	± 0.1	-	± 1.0	μ A
Static Supply Current	ICC	5.5	VIN=VCC or GND	-	-	2.0	-	20.0	μ A

SWITCHING ELECTRICAL CHARACTERISTICS

(tr=3ns)

PARAMETER	SYMBOL	CONDITIONS		Ta=25°C			Ta=-40°C~85°C		UNITS	
		CL	VCC(V)	MIN.	TYP.	MAX.	MIN.	MAX.		
Delay Time	tPLH tPHL	15pF	2.0	RL=1kΩ	-	2.5	12.0	-	15.0	ns
			3.3		-	2.0	4.0	-	5.5	
			5.0		-	1.5	3.0	-	4.0	
	50pF	2.0	RL=1kΩ	-	4.0	20.0	-	23.0	ns	
		3.3		-	3.0	6.0	-	8.0		
		5.0		-	2.0	5.0	-	6.0		
Output Enable Time	tzL tzH	15pF	2.0	RL=1kΩ	-	8.5	45.0	-	60.0	ns
			3.3		-	4.5	9.0	-	11.0	
			5.0		-	3.5	7.5	-	9.0	
	50pF	2.0	RL=1kΩ	-	9.0	50.0	-	65.0	ns	
		3.3		-	5.0	10.0	-	12.0		
		5.0		-	4.0	8.5	-	10.0		
Output Disable Time	tlZ thZ	15pF	2.0	RL=1kΩ	-	9.0	45.0	-	55.0	ns
			3.3		-	7.0	17.0	-	20.0	
			5.0		-	6.0	14.0	-	18.0	
	50pF	2.0	RL=1kΩ	-	12.0	60.0	-	75.0	ns	
		3.3		-	10.0	23.0	-	27.0		
		5.0		-	8.0	20.0	-	25.0		
Sine Wave Distortion Rate		50pF	3.0	RL=10kΩ fIN=1kHz	-	0.05	-	-	-	%
-3dB Band Width		50pF	3.0	RL=600Ω $20\log_{10} \frac{V_{OUT}}{V_{IN}} = -3dB$	-	200	-	-	-	MHz
Feed Through (Switch off)		50pF	3.0	RL=600Ω	-	-60	-	-	-	dB
Cross Talk (Control Switches)	50pF	2.0	RL=600Ω fCONT=1MHz	-	60	-	-	-	mV	
		3.0		-	100	-	-	-		
		4.5		-	150	-	-	-		
Cross Talk (Between Switches)	50pF	2.0	RL=600Ω fIN=1MHz	-	-60	-	-	-	dB	
		3.0		-	-60	-	-	-		
		4.5		-	-60	-	-	-		
Control Input Capacitance	CCONT	-	-		-	5	10	-	10	pF
Switch Input/Output Capacitance	CIN/OUT	-	-		-	6	-	-	-	pF
Feed Through Capacitance	CIN-OUT	-	-		-	0.5	-	-	-	pF
Power Dissipation Capacitance	Cpd	-	-		-	13	-	-	-	pF

■ ON RESISTANCE

- Test Circuit

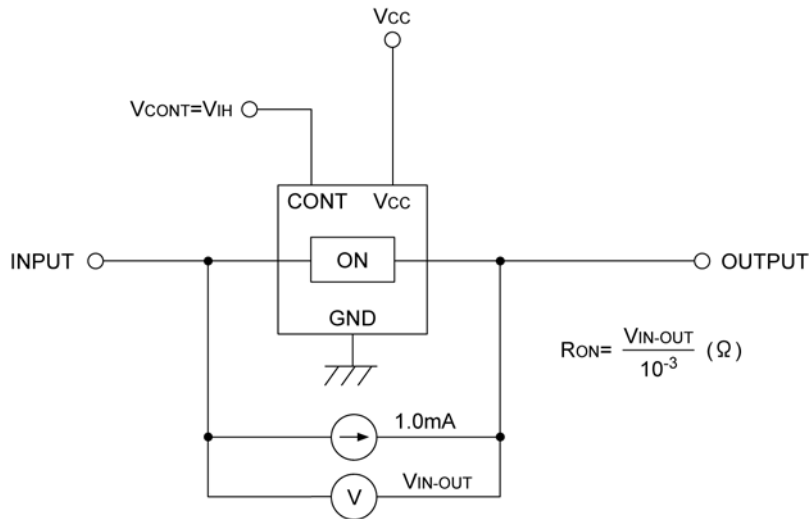

- Input Voltage Dependencies of ON Resistance

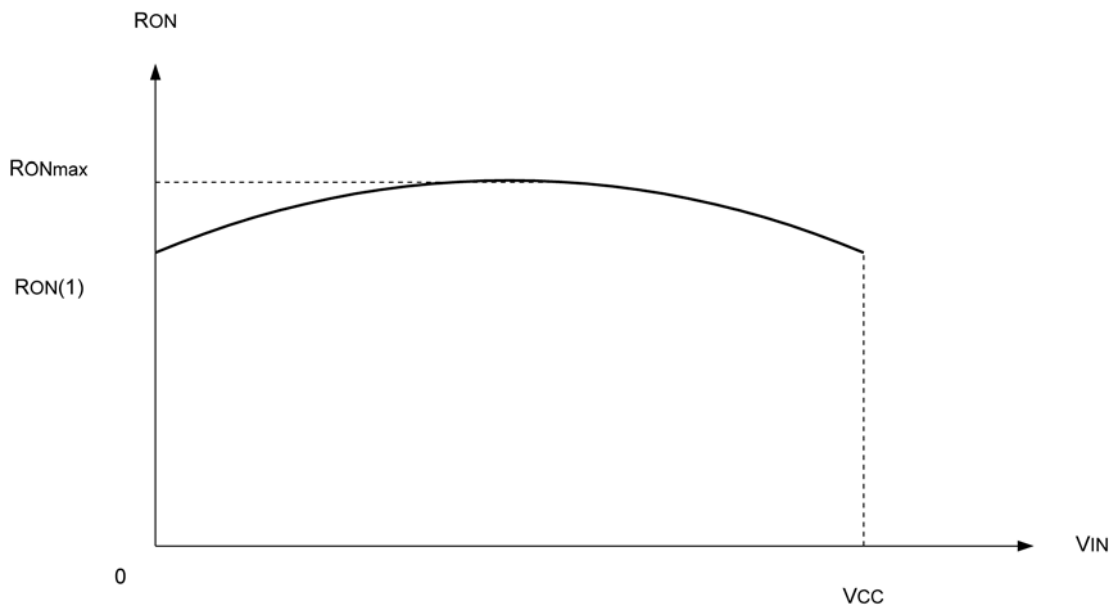

■ POWER OFF LEAK CURRENT

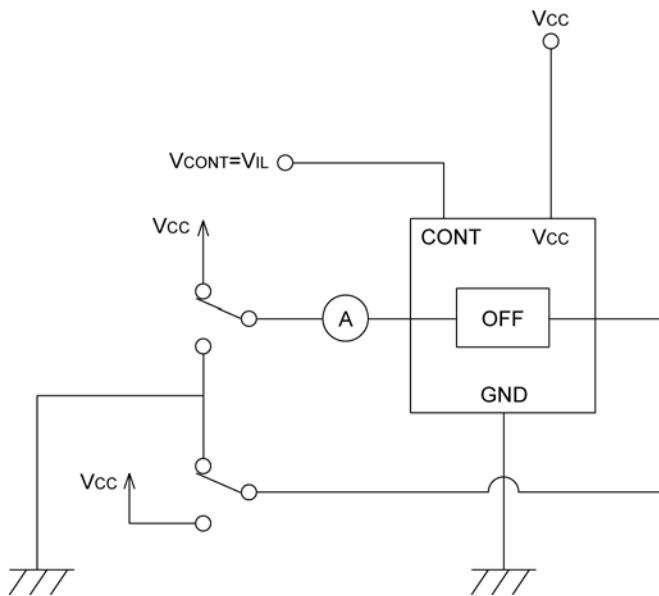

■ POWER ON LEAK CURRENT

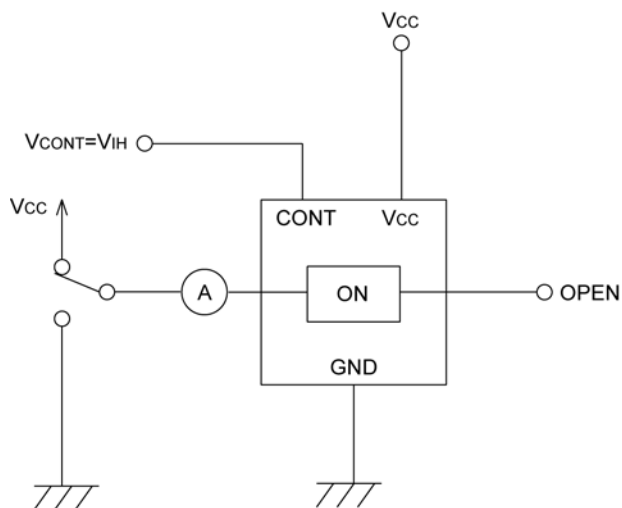

■ DELAY TIME

• Test Circuit

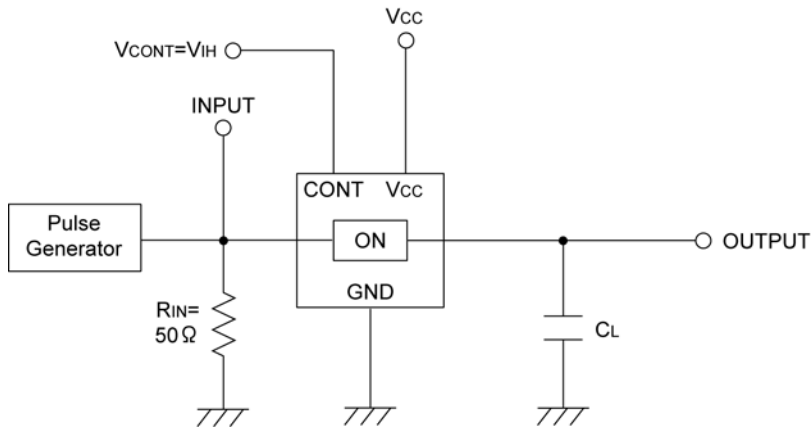

• Waveform

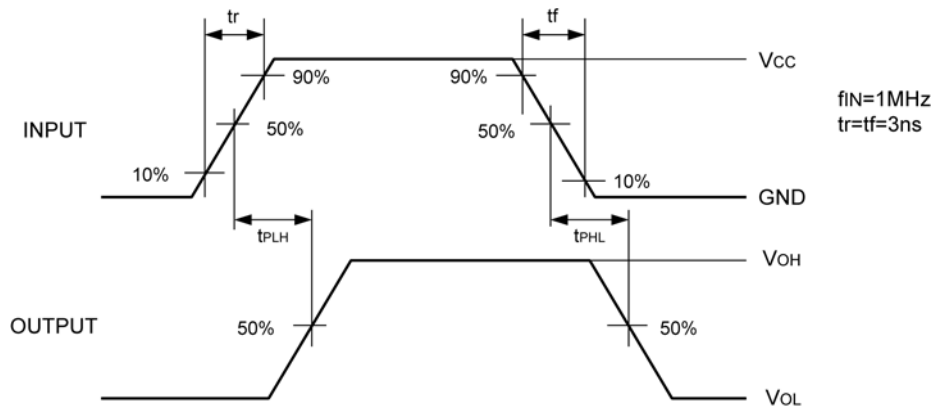

■ OUTPUT ENABLE TIME, OUTPUT DISABLE TIME

• Test Circuit

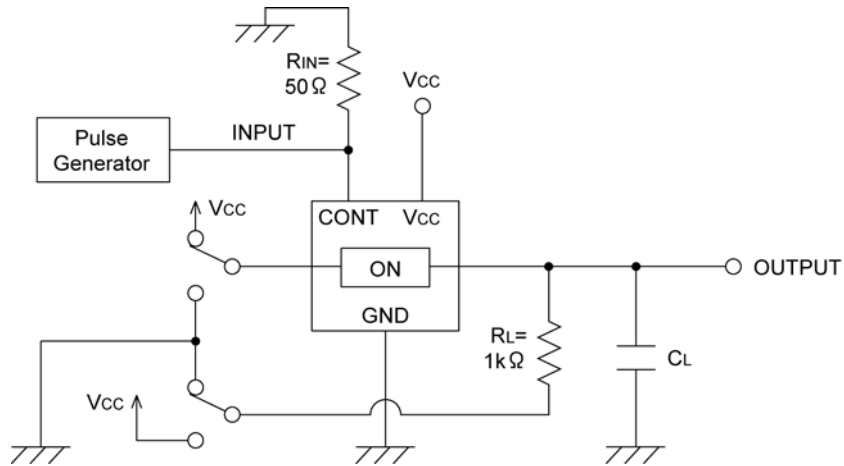

• Waveform

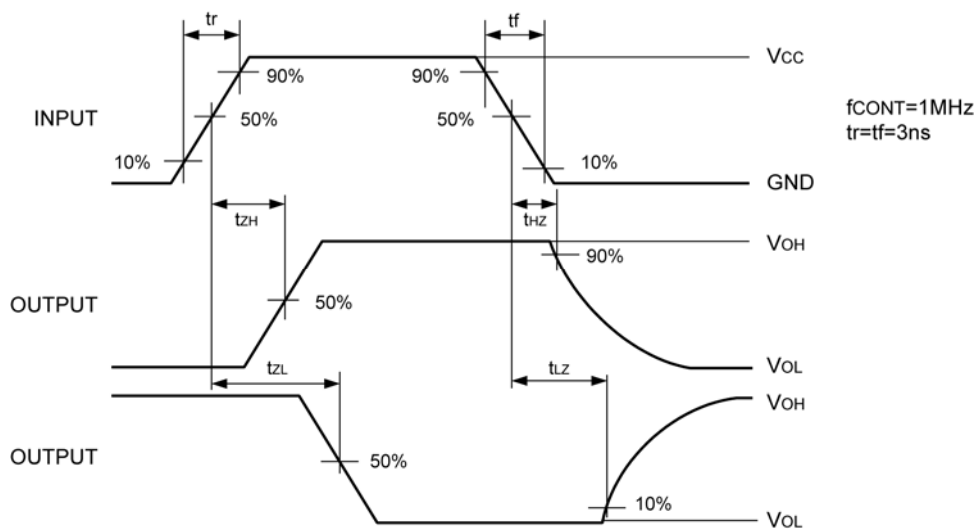

■ SINE WAVE DISTORTION RATE

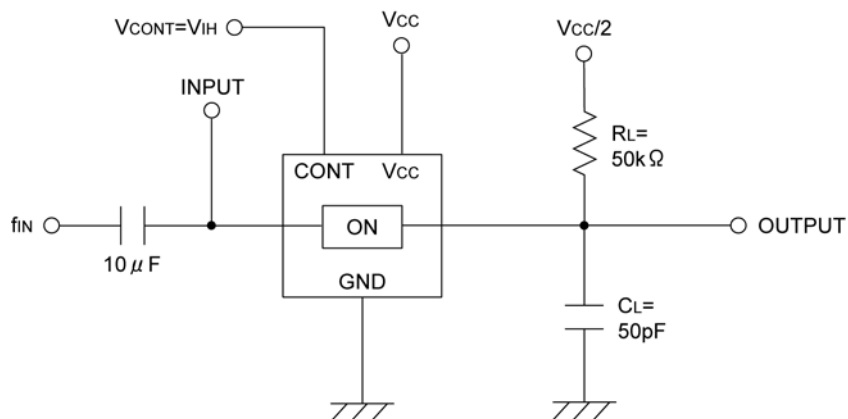

* Input by sine wave

■ -3dB BAND WIDTH

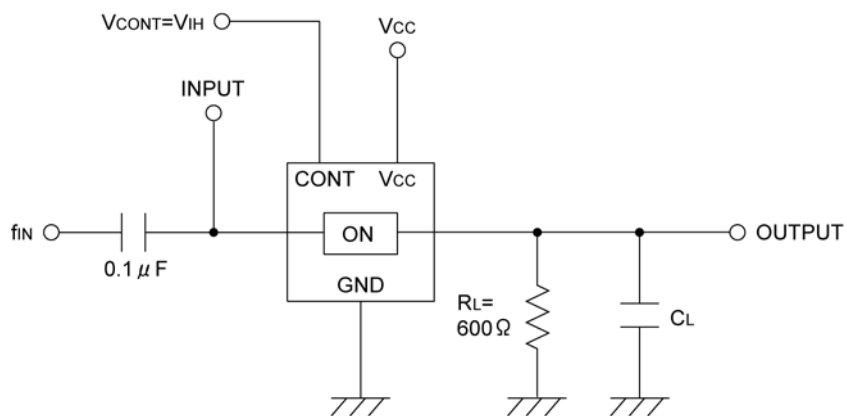

* Input by sine wave (V_{IN}=0dBm, f=1MHz)

■ FEED THROUGH TEST CIRCUIT

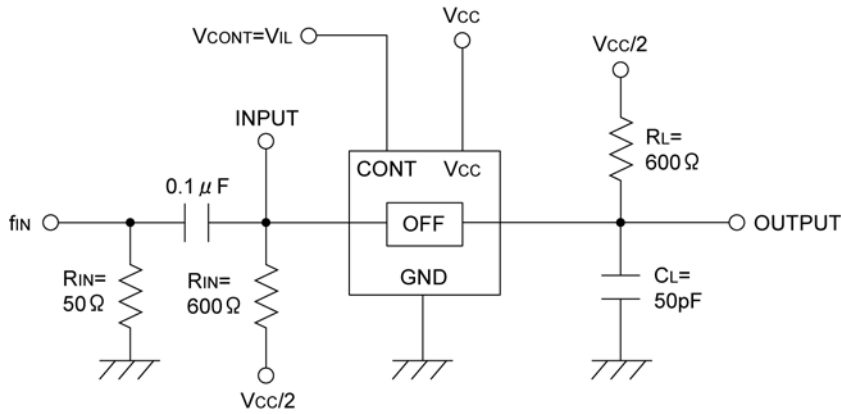

* Input by sine wave ($V_{IN}=0dBm$, $f=1MHz$)

■ CROSS TALK (CONTROL INPUT → SWITCH OUTPUT)

- Test Circuit

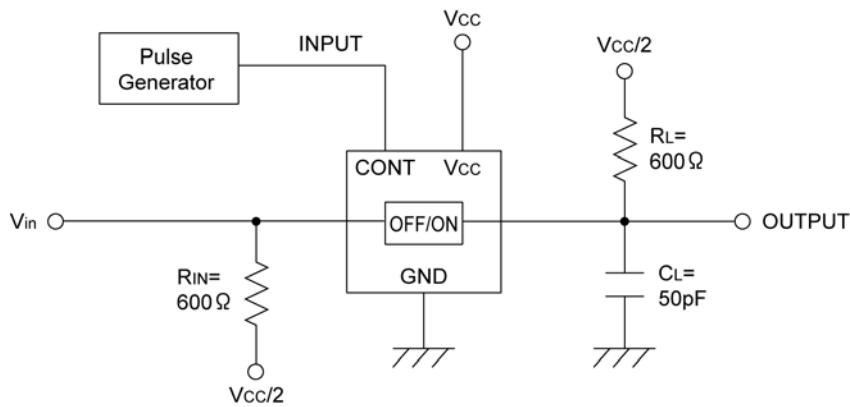

- Waveform

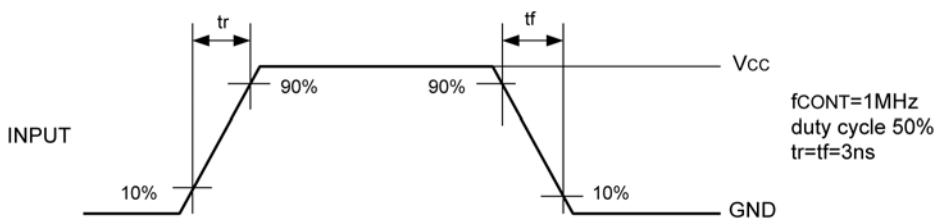

XC74WL4066SR

■ CROSS TALK (BETWEEN SWITCHES)

- Test Circuit

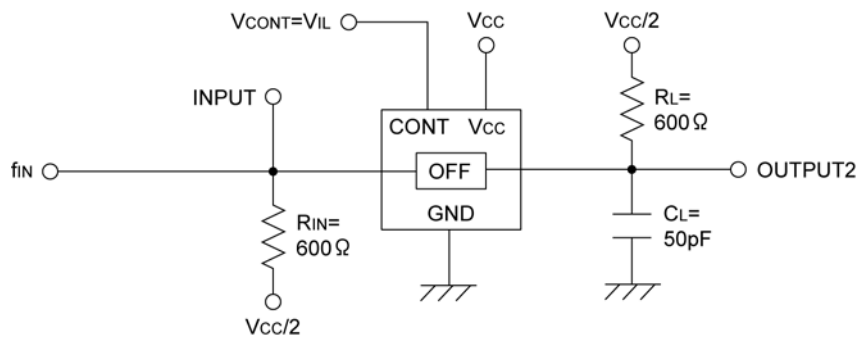
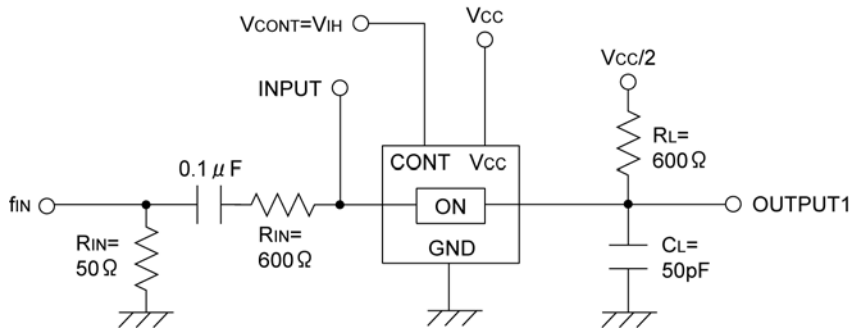

- Waveform

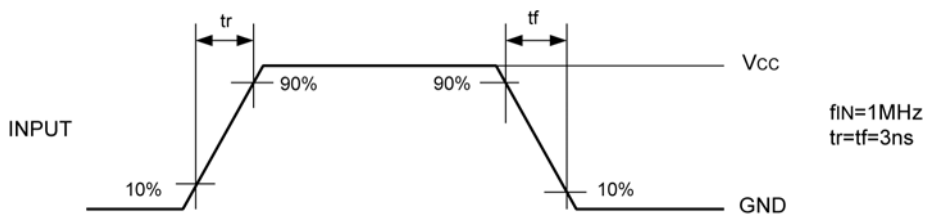

1. The products and product specifications contained herein are subject to change without notice to improve performance characteristics. Consult us, or our representatives before use, to confirm that the information in this datasheet is up to date.
2. We assume no responsibility for any infringement of patents, patent rights, or other rights arising from the use of any information and circuitry in this datasheet.
3. Please ensure suitable shipping controls (including fail-safe designs and aging protection) are in force for equipment employing products listed in this datasheet.
4. The products in this datasheet are not developed, designed, or approved for use with such equipment whose failure or malfunction can be reasonably expected to directly endanger the life of, or cause significant injury to, the user.
(e.g. Atomic energy; aerospace; transport; combustion and associated safety equipment thereof.)
5. Please use the products listed in this datasheet within the specified ranges.
Should you wish to use the products under conditions exceeding the specifications, please consult us or our representatives.
6. We assume no responsibility for damage or loss due to abnormal use.
7. All rights reserved. No part of this datasheet may be copied or reproduced without the prior permission of TOREX SEMICONDUCTOR LTD.

TOREX SEMICONDUCTOR LTD.