



CD22101, CD22102

CMOS 4 x 4 x 2 Crosspoint Switch with Control Memory

March 1993

Features

- Low ON Resistance75V Typ. at $V_{DD} = 12V$
- "Built - In" Latched Inputs
- Large Analog Signal Capability $\pm V_{DD}/2$
- Switch Bandwidth 10MHz
- Matched Switch Characteristics $\Delta R_{ON} = 8\Omega$ Typ. at $V_{DD} = 12V$
- High Linearity - 0.25% Distortion (Typ.) at $f = 1kHz$, $V_{IN} = 5Vp-p$, $V_{DD} - V_{SS} = 10V$, and $R_L = 1k\Omega$
- Standard CMOS Noise Immunity

Applications

- Telephone Systems
- PBX
- Studio Audio Switching
- Multisystem Bus Interconnect

Description

CD22101 and CD22102 crosspoint switches consist of 4 x 4 x 2 arrays of crosspoints (transmission gates) with a 4-line to 16-line decoder and 16 latch circuits. Any one of the sixteen crosspoint pairs can be selected by applying the appropriate four-line address, corresponding crosspoints in each array are turned on and off simultaneously. Any number of crosspoints can be turned on simultaneously.

In the CD22101, the selected crosspoint pair can be turned on or off by applying a logical ONE or ZERO, respectively, to the data input, and applying a ONE to the strobe input. When the device is "powered up", the states of the 16 switches are indeterminate. Therefore, all switches must be turned off by putting the strobe high, data-in low, and then addressing all switches in succession.

The selected pair of crosspoints in the CD22102 is turned on by applying a logical ONE to the K_A (set) input while a logical ZERO is on the K_B (reset) input, and turned off by applying a logical ONE to the K_B (reset) input while a logical ZERO is on the K_A input. In this respect, the control latches of the CD22102 are similar to SET/RESET flip-flops. They differ, however, in that the simultaneous application of ONE's to the K_A and K_B inputs turns off (resets) all crosspoints. All crosspoints in both devices must be turned off as V_{DD} is applied.

Ordering Information

PART NUMBER	TEMPERATURE RANGE	PACKAGE
CD22101E	-40°C to +85°C	24 Lead Plastic DIP
CD22101F	-55°C to +125°C	24 Lead Frit Seal Ceramic DIP
CD22102E	-40°C to +85°C	24 Lead Plastic DIP
CD22102F	-55°C to +125°C	24 Lead Frit Seal Ceramic DIP

Pinouts

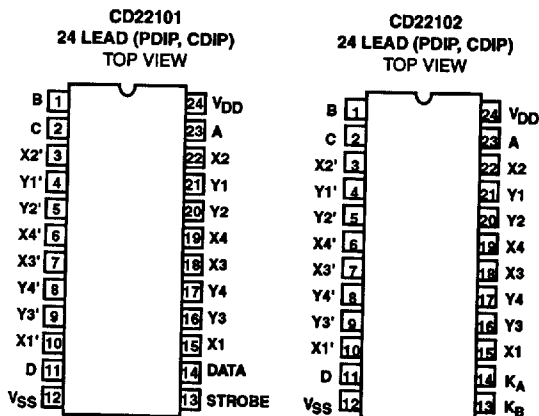

Functional Diagram

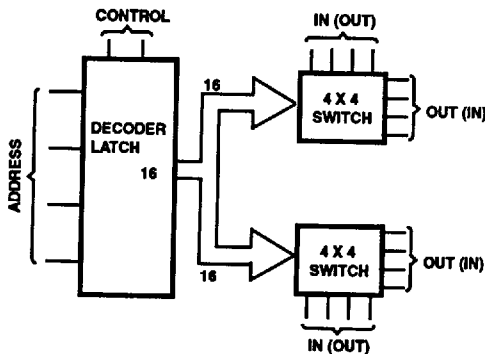

Specifications CD22101, CD22102

Absolute Maximum Ratings

Supply Voltage (V_{DD})
 (Voltages referenced to V_{SS} Terminal) -0.5 to +20V
 Input Voltage (All Inputs) -0.5 to $V_{DD} + 0.5V$
 Input Current (Any One Input) (Note 1) $\pm 10mA$
 Power Dissipation
 For $T_A = -40^\circ C$ to $+60^\circ C$ (Package Type E) 500mW
 For $T_A = +60^\circ C$ to $+85^\circ C$
 Package Type E) Derate Linearly 12mW/ $^\circ C$ to 200mW
 For $T_A = -55^\circ C$ to $+100^\circ C$ (Package Type D, F) 500mW
 For $T_A = +100^\circ C$ to $+125^\circ C$
 (Package Type D, F) Derate Linearly 12mW/ $^\circ C$ to 200mW
 Device Dissipation per Output Transistor
 For $T_A =$ Full Package Temperature Range (All Types) 100mW
 Junction Temperature $+175^\circ C$
 Junction Temperature (Plastic Package) $+150^\circ C$
 Lead Temperature (Soldering 10 Sec.) $+300^\circ C$

Recommended Operating Conditions

Operating Temperature Range
 Package Type D, F, H $-55^\circ C \leq T_A \leq +125^\circ C$
 Package Type E $-40^\circ C \leq T_A \leq +85^\circ C$
 Storage Temperature Range $-65^\circ C \leq T_A \leq +150^\circ C$
 Supply Voltage Range
 For $T_A =$ Full Package Temperature Range $-3V$ to $+18V$

CAUTION: Stresses above those listed in "Absolute Maximum Ratings" may cause permanent damage to the device. This is a stress only rating and operation of the device at these or any other conditions above those indicated in the operational sections of this specification is not implied.

Static Electrical Specifications

Values at $-55^\circ C, +25^\circ C, +125^\circ C$ Apply to D, F, H Packages
 Values at $-40^\circ C, +25^\circ C, +85^\circ C$ Apply to E Package

PARAMETERS	SYMBOL	TEST CONDITIONS	LIMITS AT INDICATED TEMPERATURES								UNITS	
			FIGURE	V_{DD} (V)	$-55^\circ C$	$-40^\circ C$	$+85^\circ C$	$+125^\circ C$	$+25^\circ C$			
									MIN	TYP		MAX
CROSSPOINTS												
Quiescent Device Current	I_{DD} Max.		1	5	5	5	150	150	-	0.04	5	μA
			1	10	10	10	300	300	-	0.04	10	μA
			1	15	20	20	600	600	-	0.04	20	μA
			1	20	100	100	3000	3000	-	0.08	100	μA
On Resistance	R_{ON} Max.	Any Switch $V_{IS} = 0$ to V_{DD}	14	5	475	500	725	800	-	225	600	Ω
			15	10	135	145	205	230	-	85	180	Ω
			-	12	100	110	155	175	-	75	135	Ω
			16	15	70	75	110	125	-	65	95	Ω
ΔR_{ON} Resistance	ΔR_{ON}	Between any two switches	5	-	-	-	-	-	25	-	Ω	
			10	-	-	-	-	-	10	-	Ω	
			12	-	-	-	-	-	8	-	Ω	
			15	-	-	-	-	-	5	-	Ω	
OFF Leakage Current	I_L Max.	All switches OFF, $V_{IS} = 18V$	4	18	± 1000				-	± 1	± 100 (Note 2)	nA
CONTROLS												
Input Low Voltage	V_{IL} Max.	OFF switch $I_L < 0.2\mu A$	5	1.5				-	-	1.5	V	
			10	3				-	-	3	V	
			15	4				-	-	4	V	
Input High Voltage	V_{IH} Min.	ON switch see R_{ON} characteristic	5	3.5				3.5	-	-	V	
			10	7				7	-	-	V	
			15	11				11	-	-	V	
Input Current	I_{IN} Max.	Any control $V_{IN} = 0, 18V$	2	18	± 0.1	± 0.1	± 1	± 1	-	$\pm 10^{-5}$	± 0.1	μA

NOTE:

1. Maximum current through transmission gates (switches) = 25mA.
2. Determined by minimum feasible leakage measurement for automatic testing.

8 TELECOM

Specifications CD22101, CD22102

Dynamic Electrical Specifications $T_A = +25^\circ\text{C}$

PARAMETERS	SYMBOL	FIGURE	TEST CONDITIONS				LIMITS			UNITS
			f_{is} (kHz)	R_L (k Ω)	V_{is} (V) (Note 3)	V_{DD} (V)	MIN	TYP	MAX	
CROSSPOINTS										
Propagation Delay Time, (Switch ON) Signal Input to Output	t_{PHL}, t_{PLH}	5			5	5	-	30	60	ns
			-	10	10	10	-	15	30	ns
					15	15	-	10	20	ns
			$C_L = 50\text{pF}; t_R, t_F = 20\text{ns}$							
Frequency Response (Any switch ON)	f_{3dB}	19	1	1	5	10	-	40	-	MHz
			Sine wave input, $20 \log \frac{V_{OS}}{V_{IS}} = -3\text{dB}$							
Sine Wave Response (Distortion)	THD	-	1	1	2.5	5	-	1	-	%
			1	1	5	10	-	0.25	-	%
			1	1	7.5	15	-	0.15	-	%
Feedthrough (All switches OFF)	F_{DT}	13	1.6	0.6	2 (Note 4)	10	-	-96	-	dB
			Sine wave input							
Frequency for Signal Crosstalk Attenuation of 40dB	F_{CT}	12	-	0.6	1 (Note 4)	10	-	2.5	-	MHz
			Sine wave input					0.1		
Capacitance:										
X_N to Ground	C_{is}		-	-	-	-	25	-	pF	
Y_N to Ground			-	-	-	-	60	-	pF	
Feedthrough		C_{ios}		-	-	-	-	0.6	-	pF
CONTROLS										
Propagation Delay Time: High Impedance to High Level or Low Level Strobe to Output, CD22101	t_{PZH}, t_{PZL}	6	$R_L = 1\text{k}\Omega, C_L = 50\text{pF}, t_R, t_F = 20\text{ns}$			5	-	500	1000	ns
						10	-	230	460	ns
						15	-	170	340	ns
Data-In to Output, CD22101	t_{PZH}, t_{PZL}	7	$R_L = 1\text{k}\Omega, C_L = 50\text{pF}, t_R, t_F = 20\text{ns}$			5	-	515	1000	ns
						10	-	220	440	ns
						15	-	170	340	ns
K_A to Output, CD22102	t_{PZH}, t_{PZL}	-	$R_L = 1\text{k}\Omega, C_L = 50\text{pF}, t_R, t_F = 20\text{ns}$			5	-	500	1000	ns
						10	-	215	430	ns
						15	-	160	320	ns
Address to Output CD22101, CD22102	t_{PZH}, t_{PZL}	8	$R_L = 1\text{k}\Omega, C_L = 50\text{pF}, t_R, t_F = 20\text{ns}$			5	-	480	960	ns
						10	-	225	450	ns
						15	-	155	300	ns

Dynamic Electrical Specifications $T_A = +25^\circ\text{C}$ (Continued)

PARAMETERS	SYMBOL	TEST CONDITIONS				LIMITS			UNITS
		FIGURE	f_{IS} (kHz)	R_L (k Ω)	V_{IS} (V) (Note 3)	V_{DD} (V)	MIN	TYP	
CONTROLS (Continued)									
Propagation Delay Time: High Level or Low Level to High Impedance Strobe to Output, CD22101	t_{PHZ}, t_{PLZ}	6	$R_L = 1\text{k}\Omega, C_L = 50\text{pF},$ $t_R, t_F = 20\text{ns}$		5	-	450	900	ns
					10	-	200	400	ns
					15	-	135	270	ns
K_B to Output, CD22102	t_{PHZ}, t_{PLZ}	-	$R_L = 1\text{k}\Omega, C_L = 50\text{pF},$ $t_R, t_F = 20\text{ns}$		5	-	450	900	ns
					10	-	200	400	ns
					15	-	130	260	ns
Data-In to Output, CD22101	t_{PHZ}, t_{PLZ}	-	$R_L = 1\text{k}\Omega, C_L = 50\text{pF},$ $t_R, t_F = 20\text{ns}$		5	-	450	900	ns
					10	-	165	330	ns
					15	-	110	220	ns
$K_A \cdot K_B$ to Output, CD22102	t_{PHZ}, t_{PLZ}	-	$R_L = 1\text{k}\Omega, C_L = 50\text{pF},$ $t_R, t_F = 20\text{ns}$		5	-	280	560	ns
					10	-	130	260	ns
					15	-	90	180	ns
Address to Output CD22101, CD22102	t_{PHZ}, t_{PLZ}	8	$R_L = 1\text{k}\Omega, C_L = 50\text{pF},$ $t_R, t_F = 20\text{ns}$		5	-	425	850	ns
					10	-	190	380	ns
					15	-	130	260	ns
Minimum Strobe Pulse Width, CD22101	t_W	6	$R_L = 1\text{k}\Omega, C_L = 50\text{pF},$ $t_R, t_F = 20\text{ns}$		5	-	260	500	ns
					10	-	120	240	ns
					15	-	80	160	ns
Address to Strobe Setup or Hold Times, CD22101	t_{SU}, t_H	9	$R_L = 1\text{k}\Omega, C_L = 50\text{pF},$ $t_R, t_F = 20\text{ns}$		5	-	-160	0	ns
					10	-	-70	0	ns
					15	-	-50	0	ns
Strobe to Data-In Hold Time, CD22101	t_{HHL}, t_{HLH}	10	$R_L = 1\text{k}\Omega, C_L = 50\text{pF},$ $t_R, t_F = 20\text{ns}$		5	-	200	400	ns
					10	-	80	160	ns
					15	-	60	120	ns
Address to K_A and K_B Setup or Hold Times, CD22102	t_{SU}, t_H	-	$R_L = 1\text{k}\Omega, C_L = 50\text{pF},$ $t_R, t_F = 20\text{ns}$		5	-	-160	0	ns
					10	-	-70	0	ns
					15	-	-50	0	ns
Minimum $K_A \cdot K_B$ Pulse Width, CD22102	t_W	-	$R_L = 1\text{k}\Omega, C_L = 50\text{pF},$ $t_R, t_F = 20\text{ns}$		5	-	375	750	ns
					10	-	160	320	ns
					15	-	110	220	ns
Minimum K_A Pulse Width, CD22102	t_W	-	$R_L = 1\text{k}\Omega, C_L = 50\text{pF},$ $t_R, t_F = 20\text{ns}$		5	-	425	850	ns
					10	-	175	350	ns
					15	-	120	240	ns
Minimum K_B Pulse Width, CD22102	t_W	-	$R_L = 1\text{k}\Omega, C_L = 50\text{pF},$ $t_R, t_F = 20\text{ns}$		5	-	200	400	ns
					10	-	90	180	ns
					15	-	70	140	ns

8
TELECOM

Dynamic Electrical Specifications $T_A = +25^\circ\text{C}$ (Continued)

PARAMETERS	SYMBOL	FIGURE	TEST CONDITIONS				LIMITS			UNITS
			f_{is} (kHz)	R_L (k Ω)	V_{is} (V) (Note 3)	V_{DD} (V)	MIN	TYP	MAX	
CONTROLS (Continued)										
Control Crosstalk, Data-In, Address or Strobe to Output		11	100	10		5	-	75	-	mV (peak)
			Square wave input = 5V, $t_r, t_f = 20\text{ns}$, $R_S = 1\text{k}\Omega$							
Input Capacitance	C_{IN}		Any Control Input			-	-	5	7.5	pF

- NOTE:
 3. Peak-to-peak voltage symmetrical about $\frac{V_{DD}}{2}$, unless otherwise specified.
 4. RMS

Functional Block Diagram

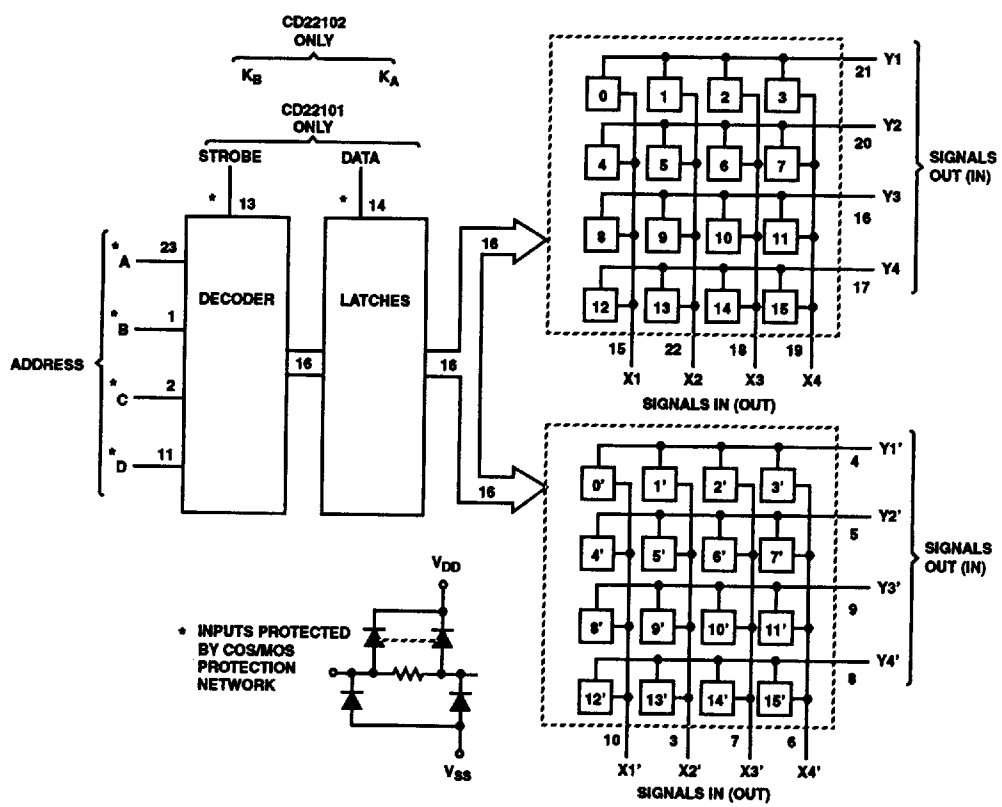

Schematic Diagram

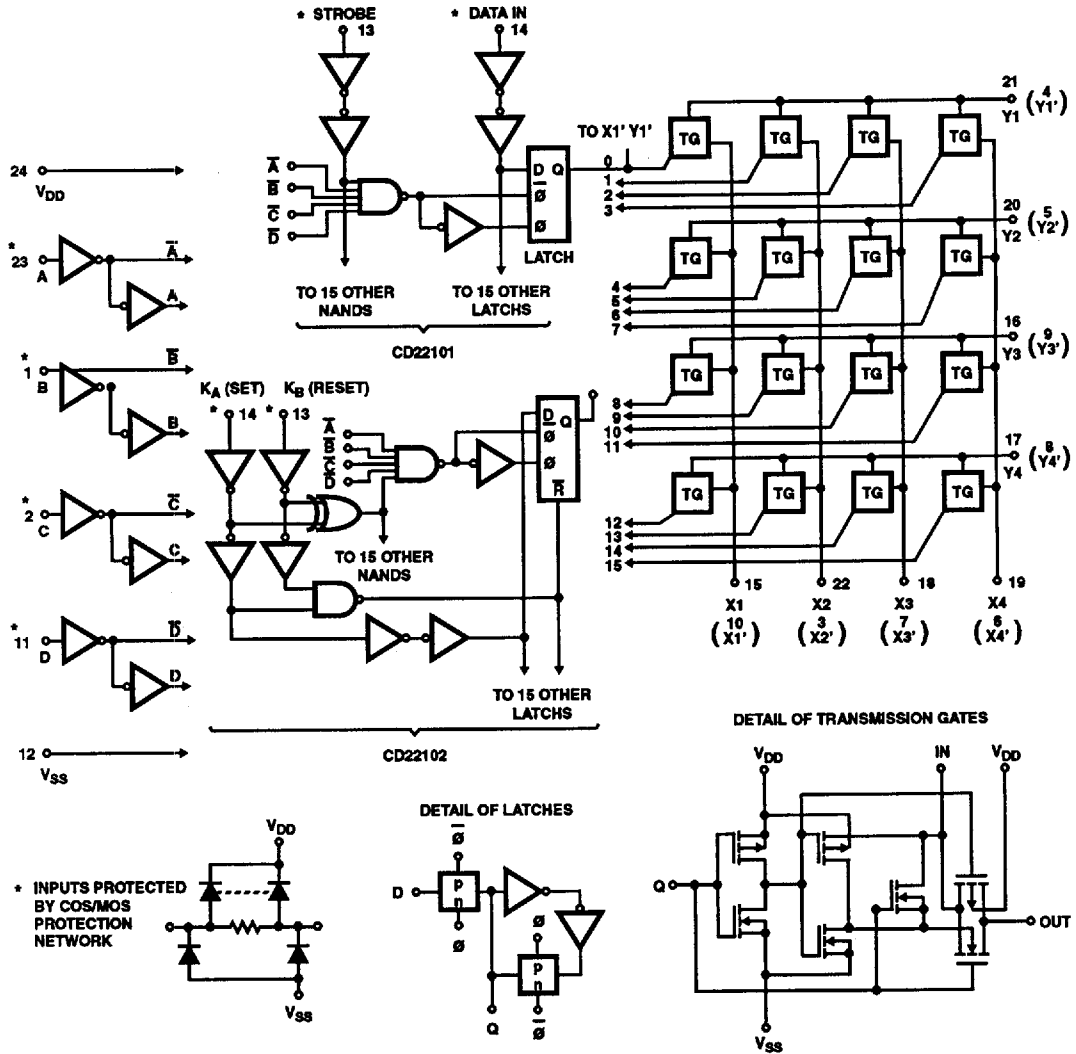

DECODER TRUTH TABLE

ADDRESS				SELECT	ADDRESS				SELECT
A	B	C	D		A	B	C	D	
0	0	0	0	X1Y1 and X1'Y1'	0	0	0	1	X1Y3 and X1'Y3'
1	0	0	0	X2Y1 and X2'Y1'	1	0	0	1	X2Y3 and X2'Y3'
0	1	0	0	X3Y1 and X3'Y1'	0	1	0	1	X3Y3 and X3'Y3'
1	1	0	0	X4Y1 and X4'Y1'	1	1	0	1	X4Y3 and X4'Y3'
0	0	1	0	X1Y2 and X1'Y2'	0	0	1	1	X1Y4 and X1'Y4'
1	0	1	0	X2Y2 and X2'Y2'	1	0	1	1	X2Y4 and X2'Y4'
0	1	1	0	X3Y2 and X3'Y2'	0	1	1	1	X3Y4 and X3'Y4'
1	1	1	0	X4Y2 and X4'Y2'	1	1	1	1	X4Y4 and X4'Y4'

TELECOM

CONTROL TRUTH TABLE FOR CD22101

FUNCTION	ADDRESS				STROBE	DATA	SELECT
	A	B	C	D			
Switch On	1	1	1	1	1	1	15 (X4Y4) and 15' (X4'Y4')
Switch Off	1	1	1	1	1	0	15 (X4Y4) and 15' (X4'Y4')
No Change	X	X	X	X	0	X	X X X X

1 = High Level

0 = Low Level

X = Don't Care

CONTROL TRUTH TABLE FOR CD22102

FUNCTION	ADDRESS				K _A	K _B	SELECT
	A	B	C	D			
Switch On	1	1	1	1	1	0	15 (X4Y4) and 15' (X4'Y4')
Switch Off	1	1	1	1	0	1	15 (X4Y4) and 15' (X4'Y4')
All Switches Off (Note 5)	X	X	X	X	1	1	All
No Change	X	X	X	X	0	0	X X X X

1 = High Level

0 = Low Level

X = Don't Care

NOTE:

5. In the event that K_A and K_B are changed from levels 1, 1 to 0, 0 K_B should not be allowed to go to 0 before K_A, otherwise a switch which was off will inadvertently be turned on.

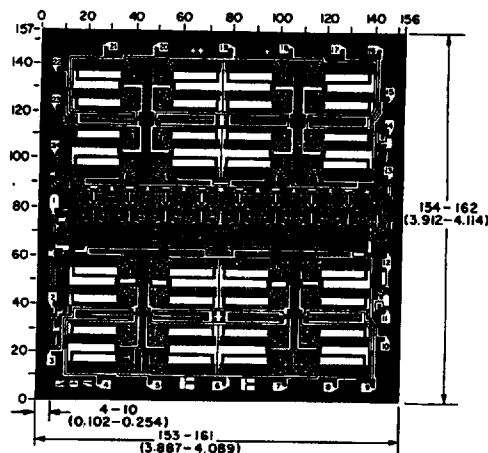
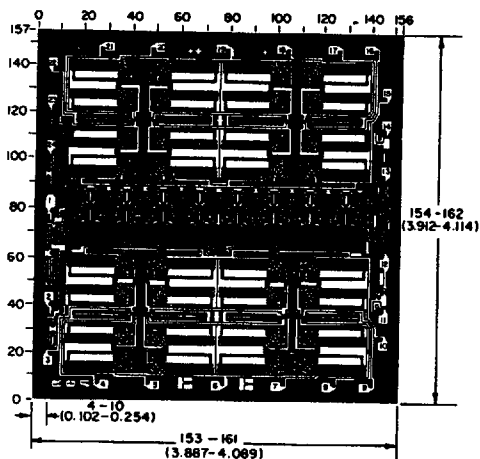
Metallization Mask Layout

Dimensions in parenthesis are in millimeters and are derived from the basic inch dimensions as indicated. Grid graduations are in mils (10^{-3} inch).

CD22101, CD22102

Test Circuits and Waveforms

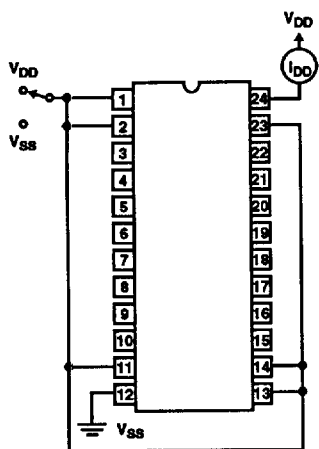
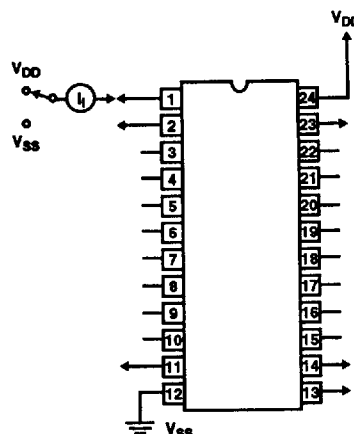
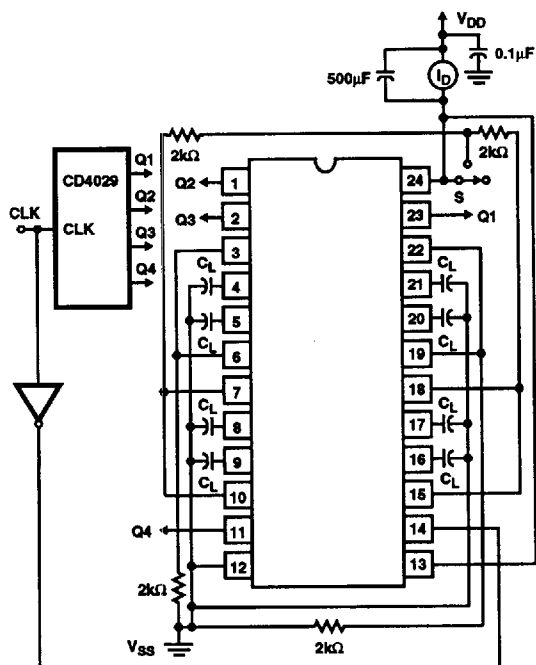

FIGURE 1. QUIESCENT CURRENT TEST CIRCUIT



NOTE:
MEASURE INPUTS SEQUENTIALLY TO BOTH V_{DD} AND V_{SS}
CONNECT ALL UNUSED INPUTS TO EITHER V_{DD} OR V_{SS}

FIGURE 2. INPUT CURRENT TEST CIRCUIT



NOTE:
CLOSE SWITCH S AFTER APPLYING V_{DD}

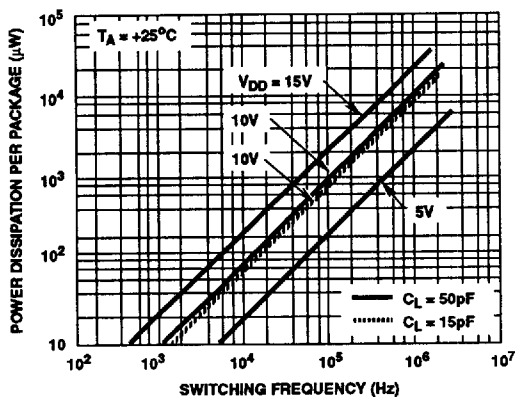

FIGURE 3. DYNAMIC POWER DISSIPATION TEST CIRCUIT FOR CD22101 AND TYPICAL DYNAMIC POWER DISSIPATION AS A FUNCTION OF SWITCHING FREQUENCY

Test Circuits and Waveforms (Continued)

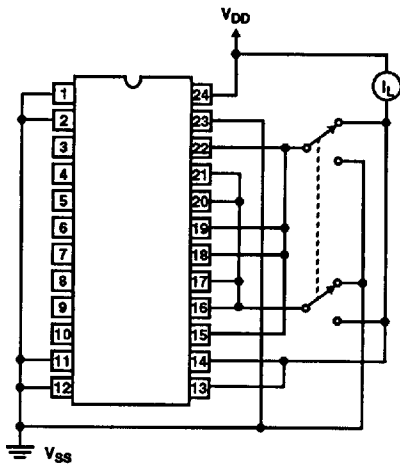
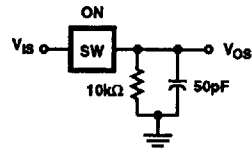

FIGURE 4. OFF SWITCH INPUT OR OUTPUT LEAKAGE CURRENT TEST CIRCUIT (16 OF 32 SWITCHES)



SW = ANY CROSSPOINT
STROBE = DATA - IN = VDD

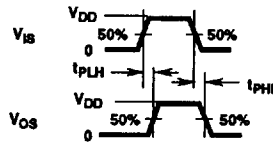
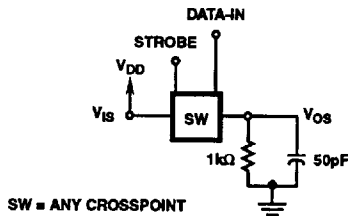

FIGURE 5. PROPAGATION DELAY TIME TEST CIRCUIT AND WAVEFORMS (SIGNAL INPUT TO SIGNAL OUTPUT, SWITCH ON)



SW = ANY CROSSPOINT

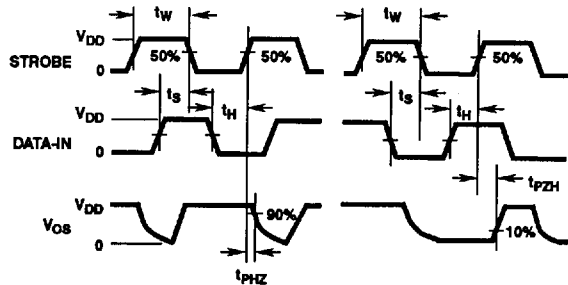
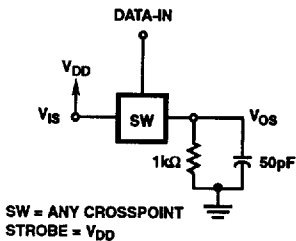

FIGURE 6. PROPAGATION DELAY TIME TEST CIRCUIT AND WAVEFORMS (STROBE TO SIGNAL OUTPUT, SWITCH TURN-ON OR TURN-OFF)



SW = ANY CROSSPOINT
STROBE = VDD

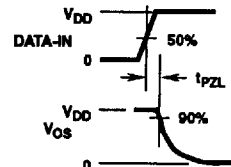
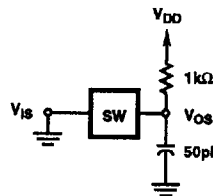
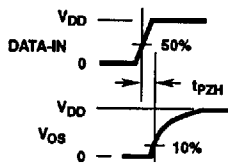

FIGURE 7. PROPAGATION DELAY TIME TEST CIRCUIT AND WAVEFORMS (DATA-IN TO SIGNAL OUTPUT, SWITCH TURN-ON TO HIGH OR LOW LEVEL)

Test Circuits and Waveforms (Continued)

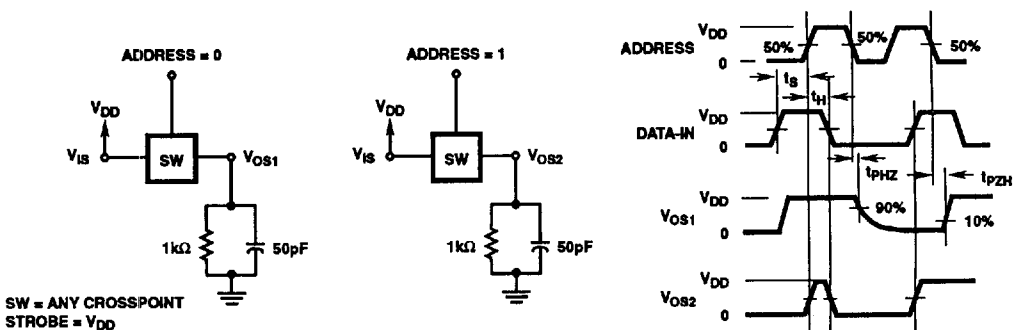
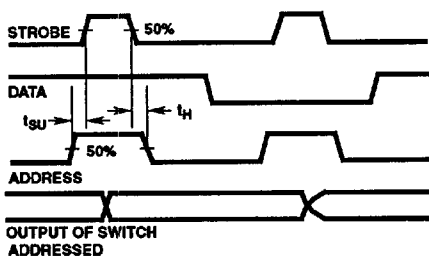
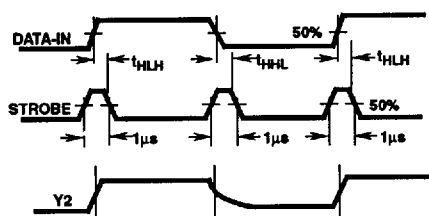

FIGURE 8. PROPAGATION DELAY TIME TEST CIRCUIT AND WAVEFORMS (ADDRESS TO SIGNAL OUTPUT, SWITCH TURN-ON OR TURN-OFF)



NOTE:
IF SETUP AND HOLD TIMES PROVIDED ARE TOO SHORT, AN UNADDRESSED SWITCH MAY BE TURNED ON OR OFF SIMULTANEOUSLY WITH THE ADDRESSED SWITCH

FIGURE 9. ADDRESS TO STROBE SETUP AND HOLD TIMES



NOTE:
SET ALL SWITCHES TO OFF INITIALLY APPLY V_{DD} TO ALL X INPUTS AND RETURN ALL Y OUTPUTS TO V_{SS} THROUGH 1kΩ ADDRESS X1Y2 (ABCD) WITH f_M = 10kHz

FIGURE 10. STROBE TO DATA-IN HOLD TIME t_H, FOR CD22101

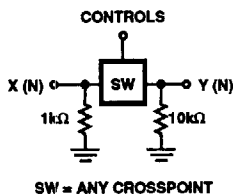

FIGURE 11. TEST CIRCUIT AND WAVEFORMS FOR CROSSTALK (CONTROL INPUT TO SIGNAL OUTPUT)

Test Circuits and Waveforms (Continued)

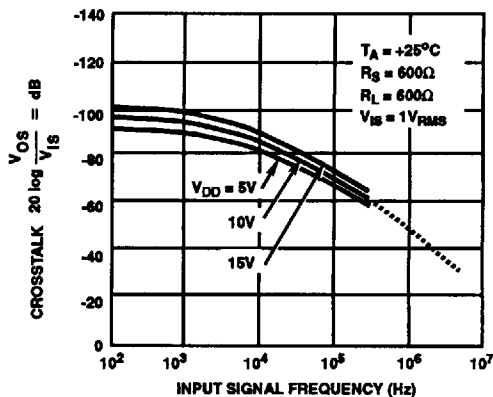
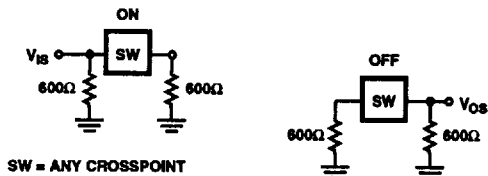

FIGURE 12. TEST CIRCUIT AND TYPICAL CROSSTALK AS A FUNCTION OF FREQUENCY BETWEEN SWITCH CIRCUITS IN THE SAME PACKAGE

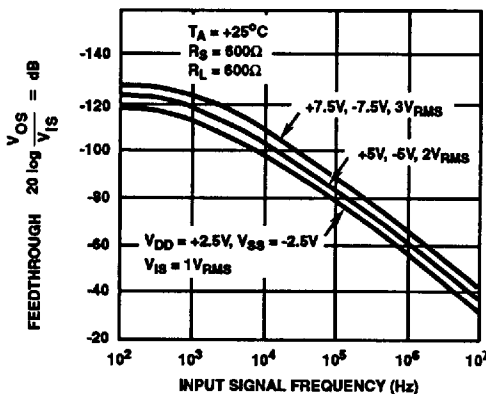
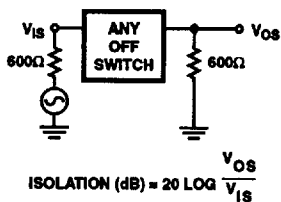

FIGURE 13. TEST CIRCUIT AND TYPICAL FEEDTHROUGH AS A FUNCTION OF FREQUENCY (ANY OFF SWITCH)

Typical Performance Curves

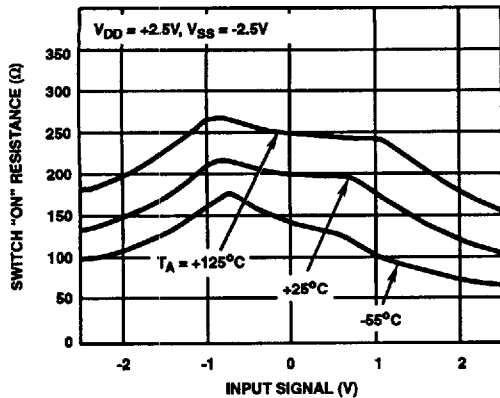

FIGURE 14. TYPICAL ON RESISTANCE AS A FUNCTION OF INPUT SIGNAL VOLTAGE AT $V_{DD} = -V_{SS} = 2.5V$

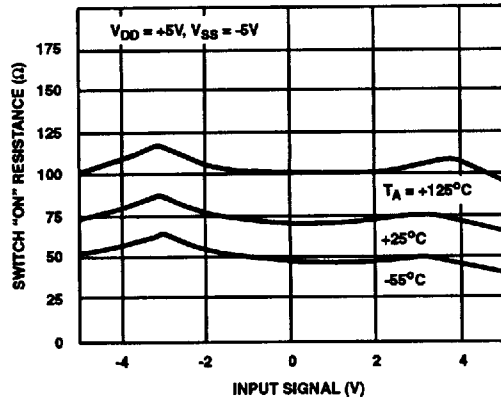

FIGURE 15. TYPICAL ON RESISTANCE AS A FUNCTION OF INPUT SIGNAL VOLTAGE AT $V_{DD} = -V_{SS} = 5V$

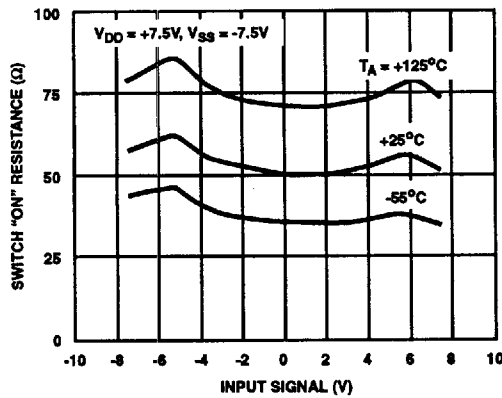

FIGURE 16. TYPICAL ON RESISTANCE AS A FUNCTION OF INPUT SIGNAL VOLTAGE AT $V_{DD} = -V_{SS} = 7.5V$

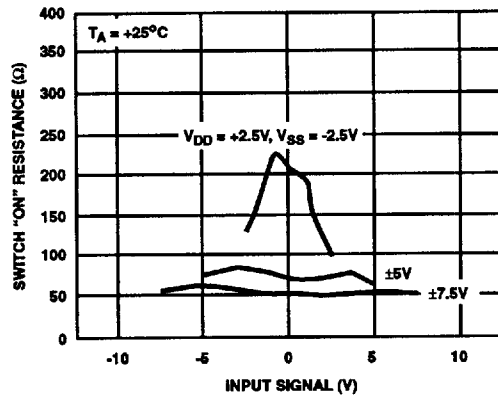

FIGURE 17. TYPICAL ON RESISTANCE AS A FUNCTION OF INPUT SIGNAL VOLTAGE AT $T_A = +25^\circ C$

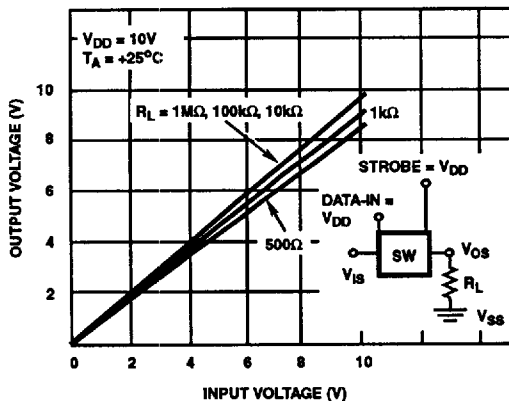

FIGURE 18. TYPICAL SWITCH ON TRANSFER CHARACTERISTICS (1 OF 16 SWITCHES)

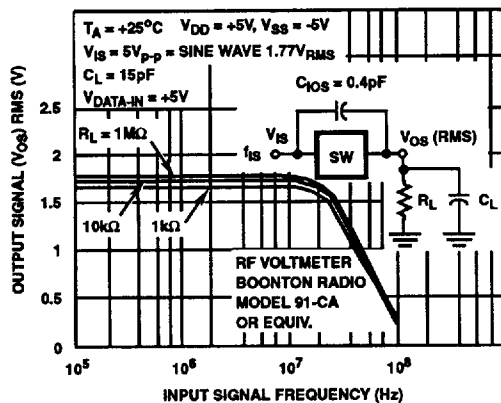

FIGURE 19. TYPICAL SWITCH ON FREQUENCY RESPONSE CHARACTERISTICS