

AVRPLC16 v6™

User manual

All MikroElektronika's development systems represent irreplaceable tools for programming and developing microcontroller-based devices. Carefully chosen components and the use of machines of the last generation for mounting and testing thereof are the best guarantee of high reliability of our devices. Due to simple design, a large number of add-on modules and ready to use examples, all our users, regardless of their experience, have the possibility to develop their project in a fast and efficient way.

Development System

 **MikroElektronika**

SOFTWARE AND HARDWARE SOLUTIONS FOR EMBEDDED WORLD ...making it simple

TO OUR VALUED CUSTOMERS

I want to express my thanks to you for being interested in our products and for having confidence in Mikroelektronika.

The primary aim of our company is to design and produce high quality electronic products and to constantly improve the performance thereof in order to better suit your needs.



Nebojsa Matic
General Manager

TABLE OF CONTENTS

General information	4
Key features	5
1.0. Connecting the development system to a power supply source	6
2.0. ATMEGA32 microcontroller	7
3.0. Programming microcontroller	8
4.0. MMC/SD connector	11
5.0. RS-485 module	12
6.0. RS-232 module	13
7.0. ADC module	14
8.0. Ethernet module	15
9.0. GSM module	16
10.0. RTC module	19
11.0. A/D inputs	20
12.0. Relays and optocouplers	21
13.0. I/O ports	22

General information

The AVRPLC16 v6™ development system provides a full-featured platform intended for development of devices used in industry. It is connected to these devices via relays. The development system features numerous modules using different communication standards such as RS-485, RS-232, Ethernet etc. In addition to these communication modules, the development system also features ADC module, RTC module and MMC/SD connector.

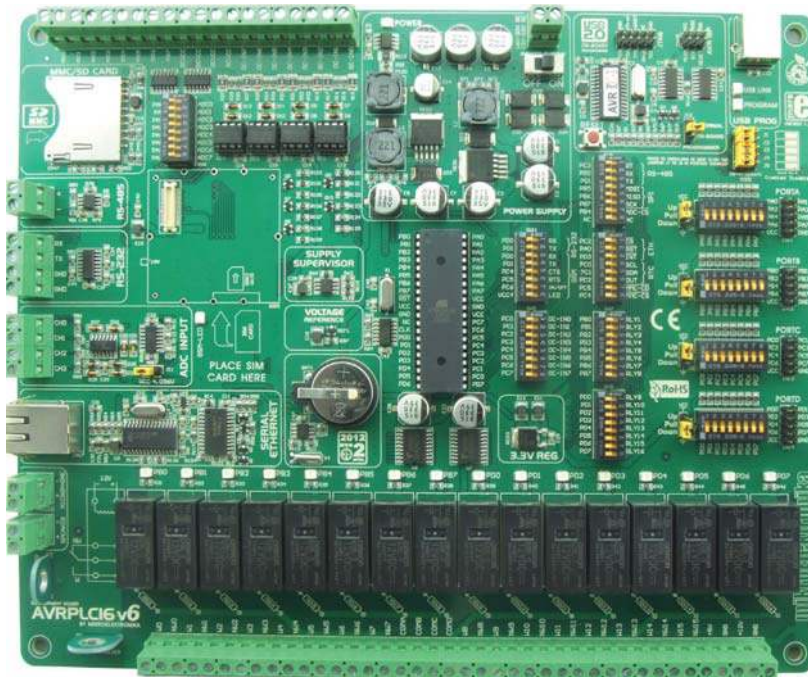

Development system for **AVR** microcontroller based devices

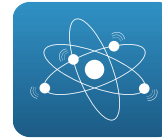

Telit GM862-GPS module with antennas

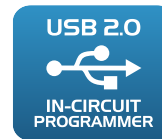

On-board programmer



Enabled access to the development system via **GSM/GPRS** communication network

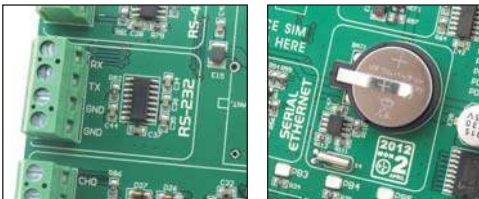

The AVRFLASH™ provides a complete list of all supported microcontrollers. The latest version of this program with updated list of supported microcontrollers can be downloaded from our website at www.mikroe.com

Package contains:

Development system: AVRPLC16 v6
 CD: product CD with relevant software
 Cables: USB cable
 Documentation: Manuals for AVRPLC16 v6 and AVRflash, Installing USB drivers and electrical schematic of the development system

System specification:

Power supply: over the CN1 screw connector (12-22V AC or 16-30V DC)
 Power consumption: ~120mA when all on-board modules are off
 Dimensions: 26,5 x 22cm (10,4 x 8,6inch)
 Weight: ~750g (0.92lbs)

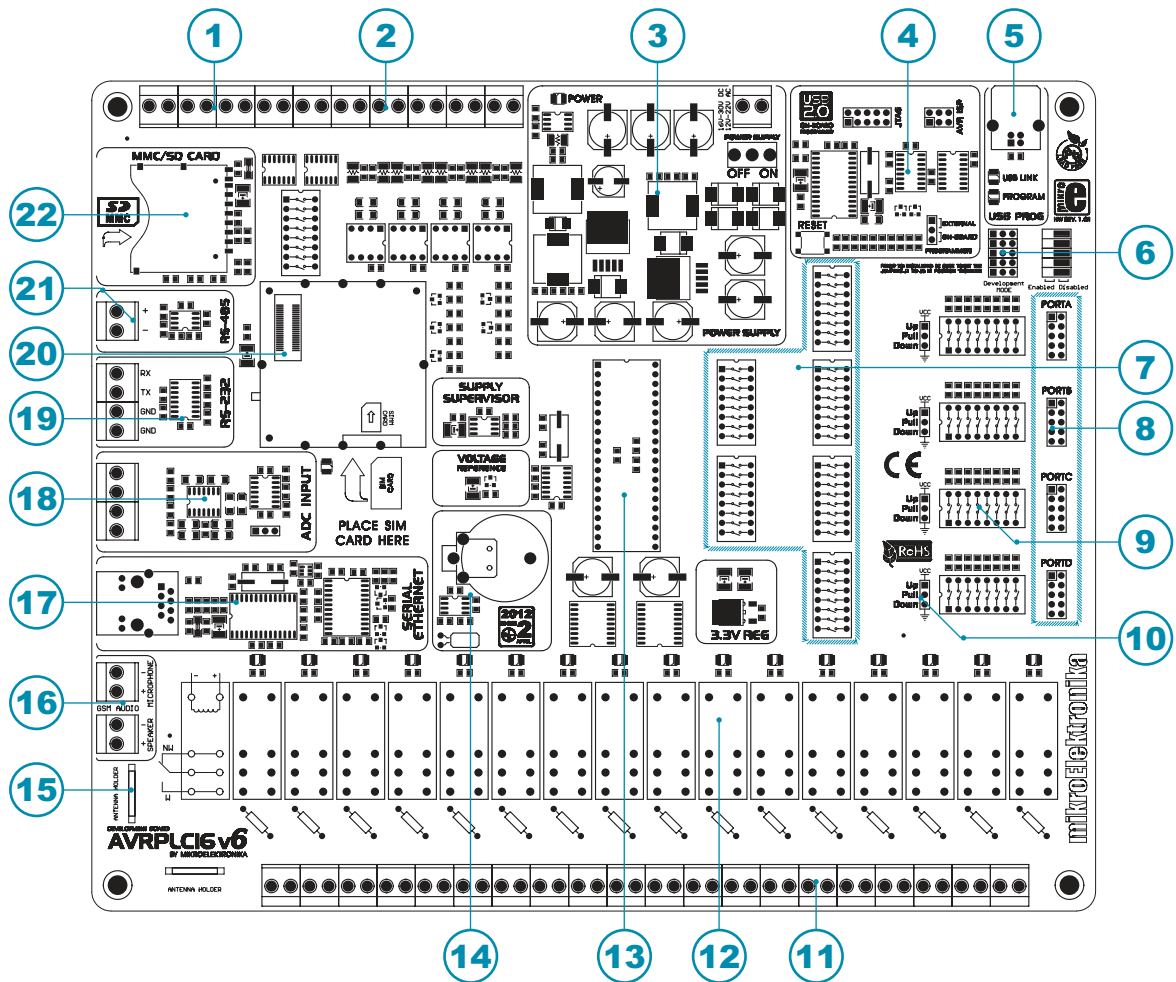

Key features

1. Screw terminals used to supply AD inputs with signals
2. Inputs used to supply optocouplers with signals
3. Power supply
4. On-board programmer
5. On-board programmer's USB connector
6. Jumpers used to switch the function of the programming pins
7. DIP switches used to turn on/off on-board modules
8. I/O ports
9. DIP switch used to turn on pull-up/pull-down resistors
10. Jumpers used to select pull-up/pull-down resistors' logic level
11. Screw terminals used to connect relays
12. 16 relays
13. Microcontroller in DIP40 package
14. Real-time clock
15. Antenna holder
16. Screw terminals used to connect earphones and microphone
17. Serial Ethernet module
18. ADC module
19. RS-232 module
20. Connector for GSM/GPRS module
21. RS-485 module
22. Connector for MMC/SD memory card

1.0. Connecting the development system to a power supply

In order to enable the development system to be turned on, it is necessary to provide the power supply voltage over a screw connector CN1, Figure 1-1.

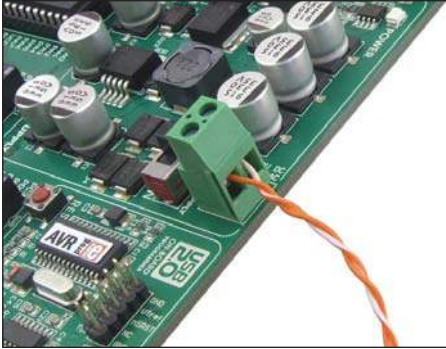

Figure 1-1: Providing power supply voltage

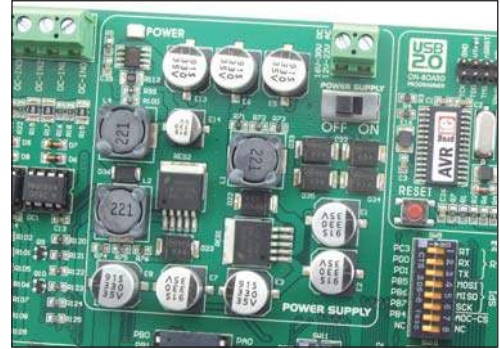

Figure 1-2: Power supply voltage regulator

The power supply voltage provided via the CN1 screw connector may be in a range between 12 and 22V AC or 16 and 30V DC. In the latter case, it is not necessary to pay attention to polarity as the power supply module takes care of that.



Figure 1-3: Power supply on/off switch

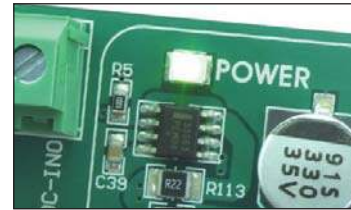

Figure 1-4: POWER LED

When the development system is powered, it is necessary to set switch marked POWER SUPPLY to the ON position, Figure 1-3. As soon as the development system is turned on, a green LED marked POWER will automatically illuminate.

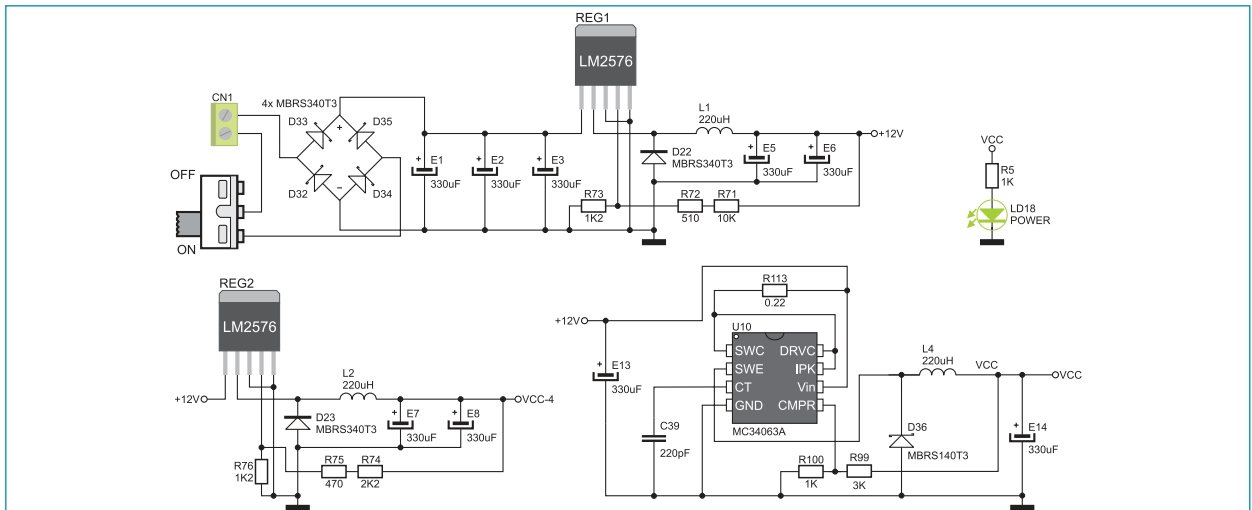

Figure 1-5: MMC/SD connector connection schematic

2.0. ATMEGA32 microcontroller

The AVRPLC16 v6 development system comes with the ATMEGA32 microcontroller in DIP40 package. It's key features are as follows:

- Low-power 8-bit AVR microcontroller
- 32Kb Flash memory
- 1024Kb EEPROM memory
- JTAG interface
- 8-channel 10-bit ADC
- Serial USART
- 32 I/O pins
- 0-16MHz speed

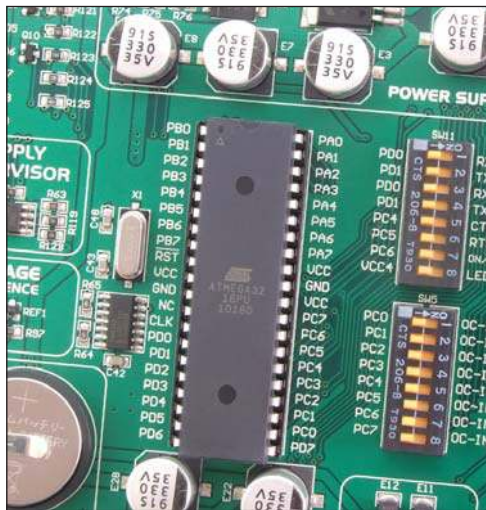

Figure 2-1: ATMEGA32 microcontroller

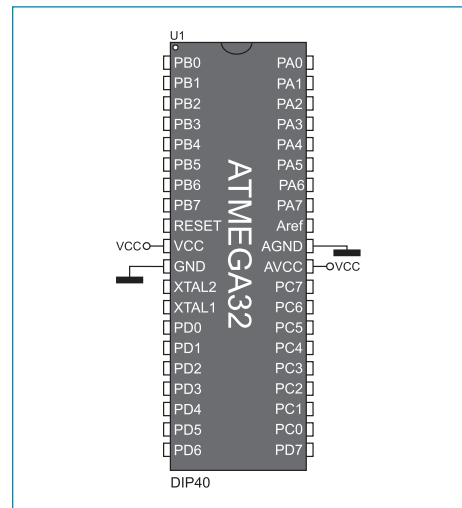

Figure 2-2: Microcontroller's pinout

The microcontroller provided on the development system can be easily replaced with another one in DIP40 package. When choosing another microcontroller, it is very important to compare its and ATMEGA32's pinouts to make sure that they are compatible. If you use a microcontroller with different pinout, some modules on the development system will probably not work.

page 3.0. Programming microcontroller

The ATMEGA32 microcontroller on the development system is programmed with on-board AVRprog or external AVR ISP and JTAG programmers, Figure 3-1.



Figure 3-1: AVRprog programmer

First, you should write a program and compile it into a .hex file in a compiler. Then, you should load the .hex file into the microcontroller. The on-board programmer is connected to the PC via a USB cable, Figure 3-2 (A and B).

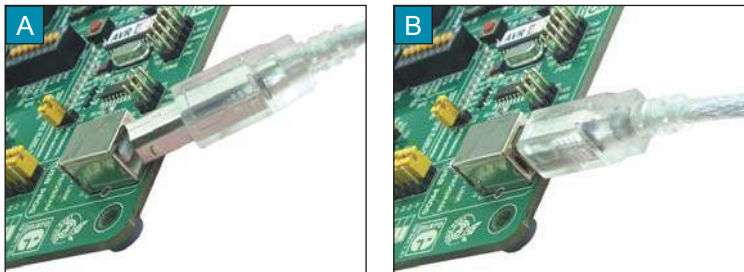

Figure 3-2: Programmer and PC connection

Loading .hex file into the microcontroller is enabled due to the AVRFLASH program provided on the product CD delivered with the development system.

NOTE: To learn more about the AVRFLASH program, refer to the relevant manual that also comes along with the development system.

A multiplexer is part of the on-board programmer. This circuit enables the programming pins to be disconnected from the development system while the programming process is in progress, Figure 3.

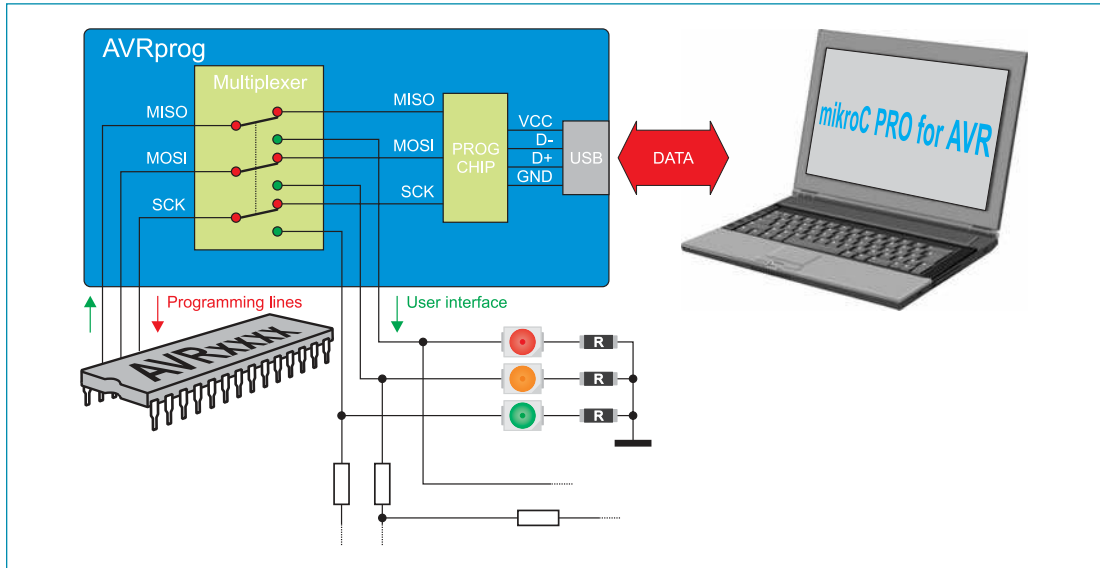

Figure 3-3: Multiplexing

In addition to the on-board programmer, the microcontroller can be programmed with the AVR ISP external programmer that is connected to the development system via the CN45 connector. The JTAG emulator, connected via a 2x5 connector CN46, can also be used for programming.



Figure 3-4: External programmer

Depending on the programmer that is used to program the microcontroller, it is necessary to place jumper J10 in the appropriate position, Figure 3-5.

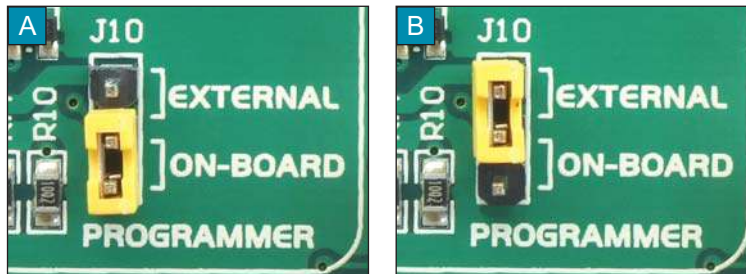

Figure 3-5: The position of jumper J10

A The on-board programmer is in use when jumper J10 is placed in the ON-BOARD position

B The external programmer is in use when jumper J10 is placed in the EXTERNAL position

If necessary, the microcontroller's programming pins may be disconnected from the programmer. Placing jumpers J1-J5 in the Disabled position causes the programming pins to be disconnected from the programmer, and at the same time connected to the rest of the development system. In this case they can be used as I/O pins.

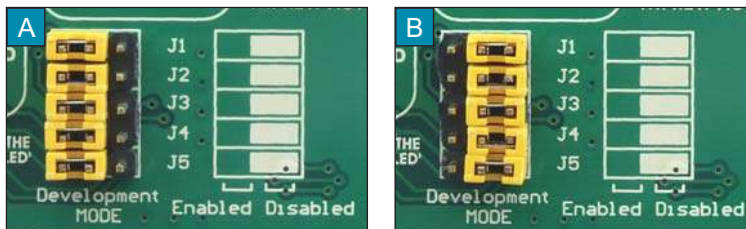

Figure 3-6: The position of jumpers J1-J5

A J1-J5 in Enabled position, the microcontroller's programming pins are connected to the programmer

B J1-J5 in Disabled position, the microcontroller's programming pins are not connected to the programmer

4.0. MMC/SD connector

The development system is capable of reading memory cards due to an on-board MMC/SD connector CN47. Memory card communicates with the microcontroller via the Serial Peripheral Interface (SPI). In order to establish the SPI connection, it is necessary to turn on the appropriate switches on the DIP switches SW9 and SW10, Figure 4-3.

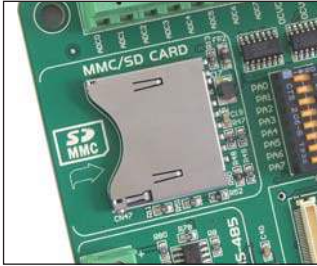

Figure 4-1: MMC/SD connector

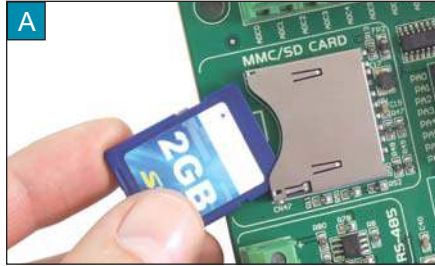

Figure 4-2: Inserting MMC/SD card

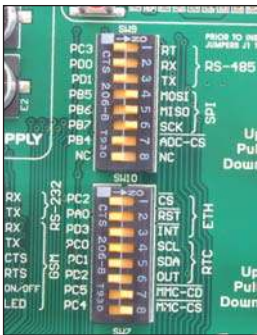

Figure 4-3: The position of DIP switches SW9 and SW10

To connect a memory card to the microcontroller, it is necessary to set switches 4, 5 and 6 on the DIP switch SW9, as well as switches 7 and 8 on the DIP switch SW10 to the ON position.

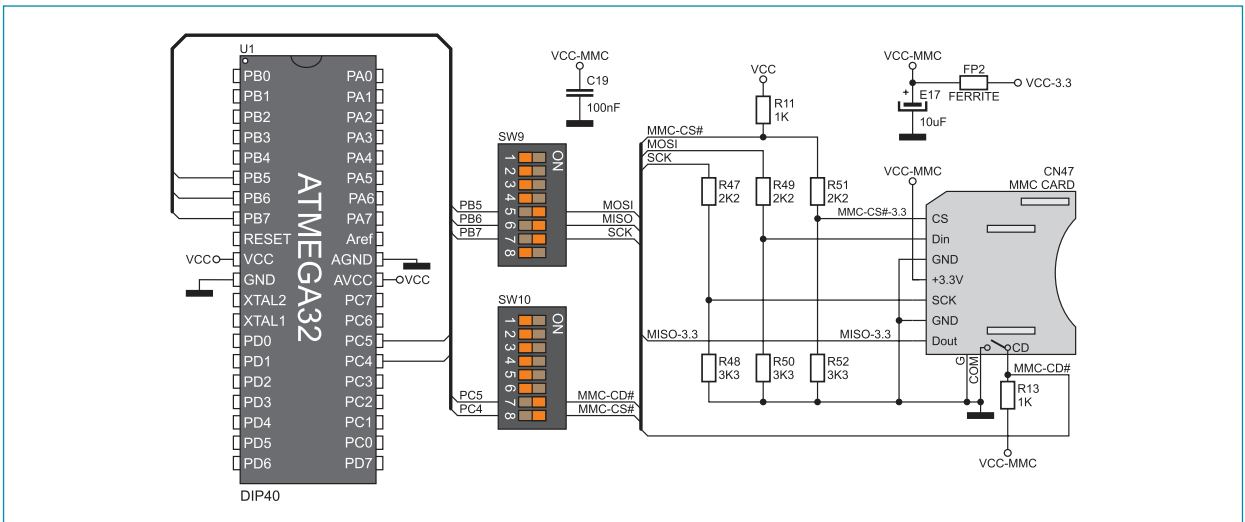

Figure 4-3: MMC/SD connector connection schematic

5.0. RS-485 module

The RS-485 module enables the development system to communicate to external devices whose operation is in compliance with the RS-485 standard. The connection between this module and one of these devices is established via a screw connector CN10, Figure 5-2. In order to turn on this module, it is necessary to set switches 1,2 and 3 on the DIP switch SW9 to the ON position, Figure 5-3.

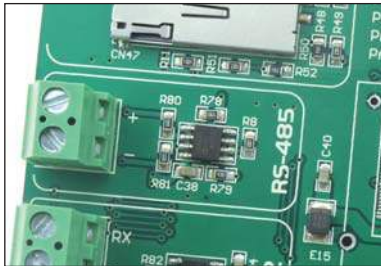

Figure 5-1: RS-485 module

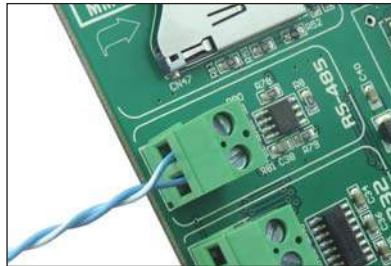

Figure 5-2: RS-485 connector

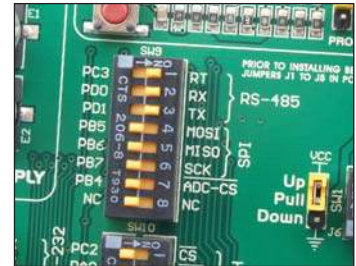

Figure 5-3: DIP switch SW9

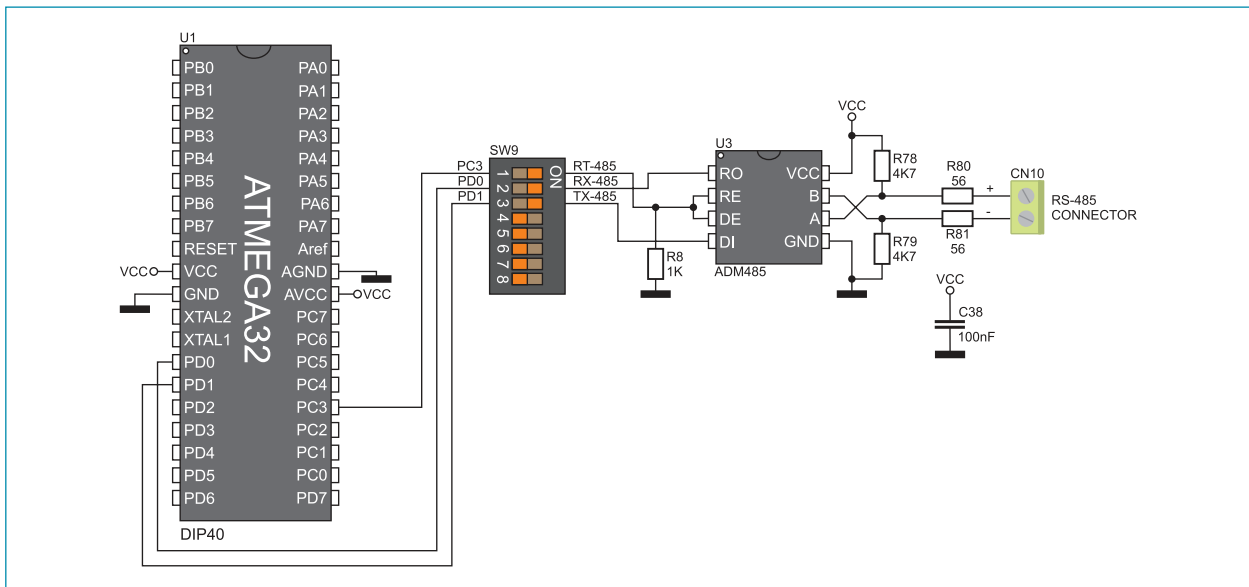

Figure 5-4: RS-485 module connection schematic

6.0. RS-232 module

The RS-232 module enables the development system to communicate to external devices whose operation is in compliance with the RS-232 standard. The connection between this module and one of these devices is established via screw terminals CN4 and CN5, Figure 6-2. In order to turn on this module, it is necessary to set switches 1 and 2 on the DIP switch SW11 to the ON position, Figure 6-3.

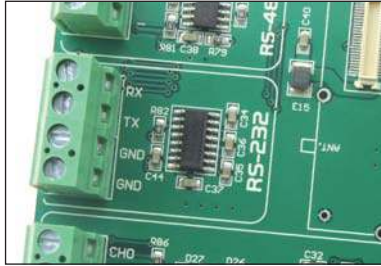

Figure 6-1: RS-232 module

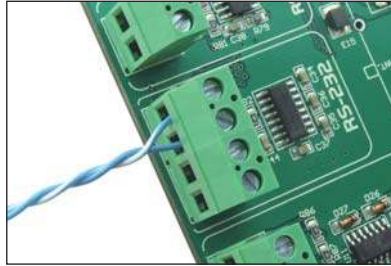

Figure 6-2: RS-232 connector

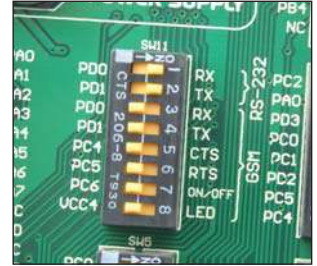

Figure 6-3: DIP switch SW11

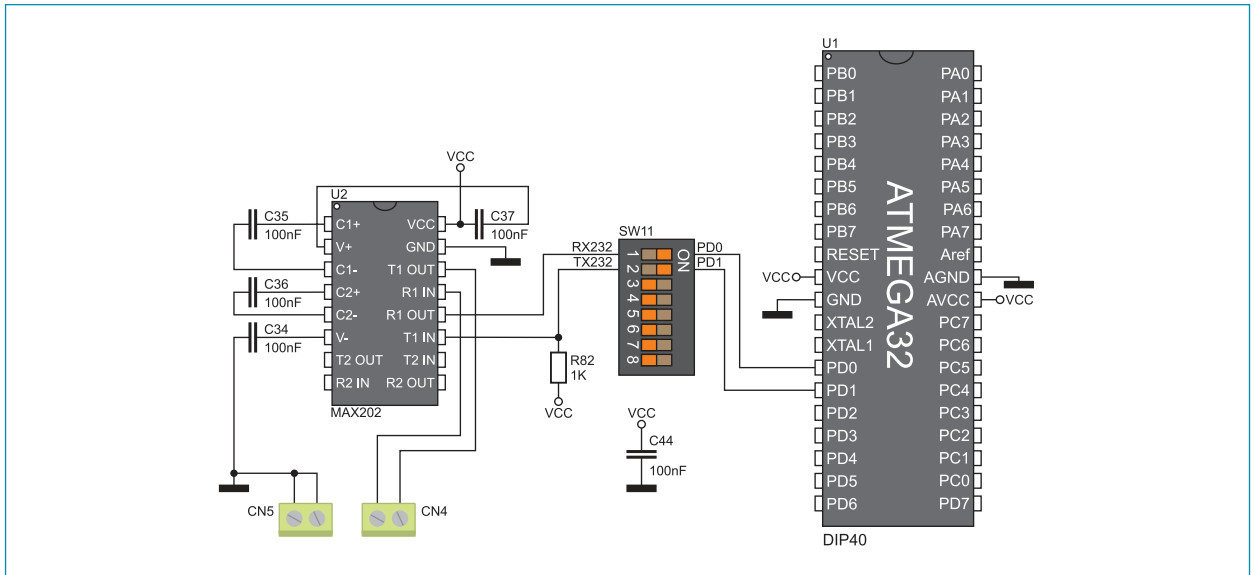

Figure 6-4: RS-232 module connection schematic

7.0. ADC module

The ADC module is used to convert an analog voltage level into the appropriate 12-bit digital value. The analog voltage signal is supplied via screw terminals CN15 and CN16. The 5V VCC or 4.096V may serve as a voltage reference source. The result of conversion is transferred from the ADC module to the microcontroller via the Serial Peripheral Interface (SPI).

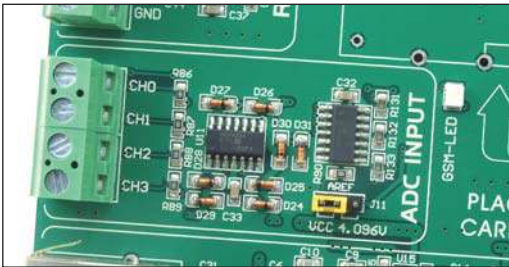

Figure 7-1: ADC module

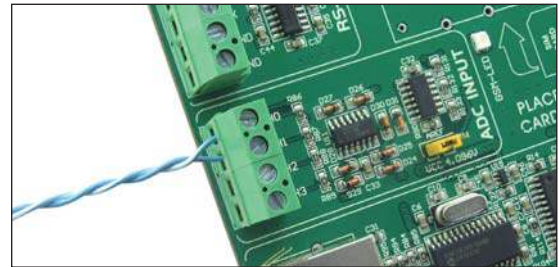

Figure 7-2: ADC module's connector

In order to enable the ADC module to be turned on, switches 4-7 on the DIP switch SW9 should be set to the ON position, Figure 7-3. Jumper 11 is used as a voltage reference source selector, Figure 7-4.

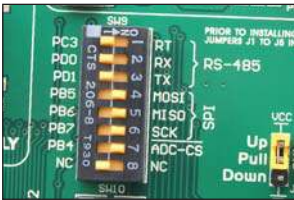

Figure 7-3: DIP switch SW9



Figure 7-4: The position of jumper J11

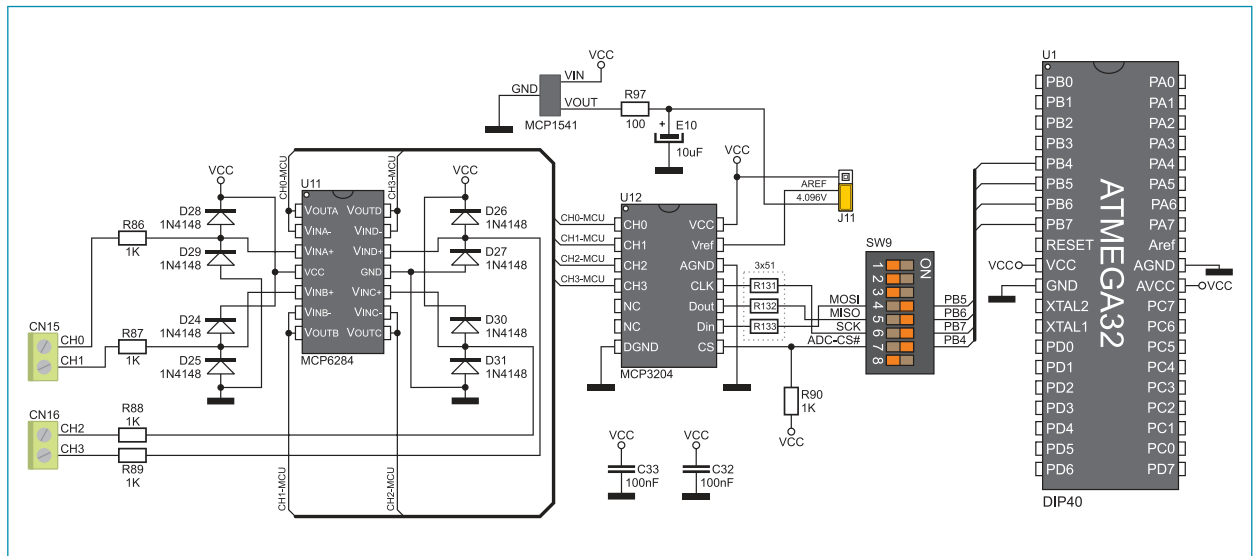

Figure 7-5: ADC module connection schematic

8.0. Ethernet module

The Ethernet module enables the development system to access the LAN network via the RJ45 connector. The operation of the Ethernet module is in compliance with the IEEE 802.3 standard. Communication between this module and the microcontroller is performed via the Serial Peripheral Interface (SPI). In order to enable the Ethernet module to be connected to the microcontroller, switches 4, 5 and 6 on the DIP switch SW9 as well as switches 1, 2 and 3 on the DIP switch SW10 should be set to the ON position, Figure 8-2.

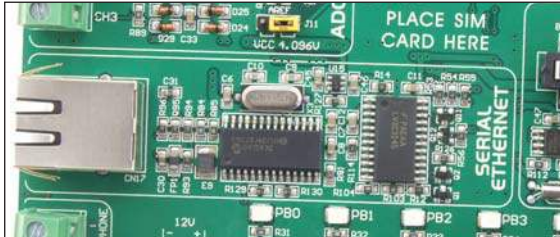

Figure 8-1: Ethernet module



Figure 8-2: DIP switches SW9 and SW10

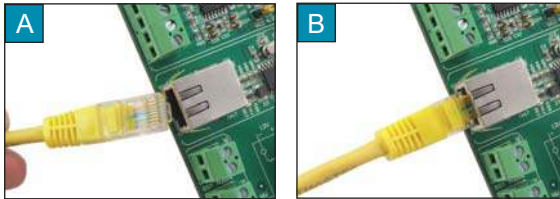

Figure 8-3: Connecting ethernet cable

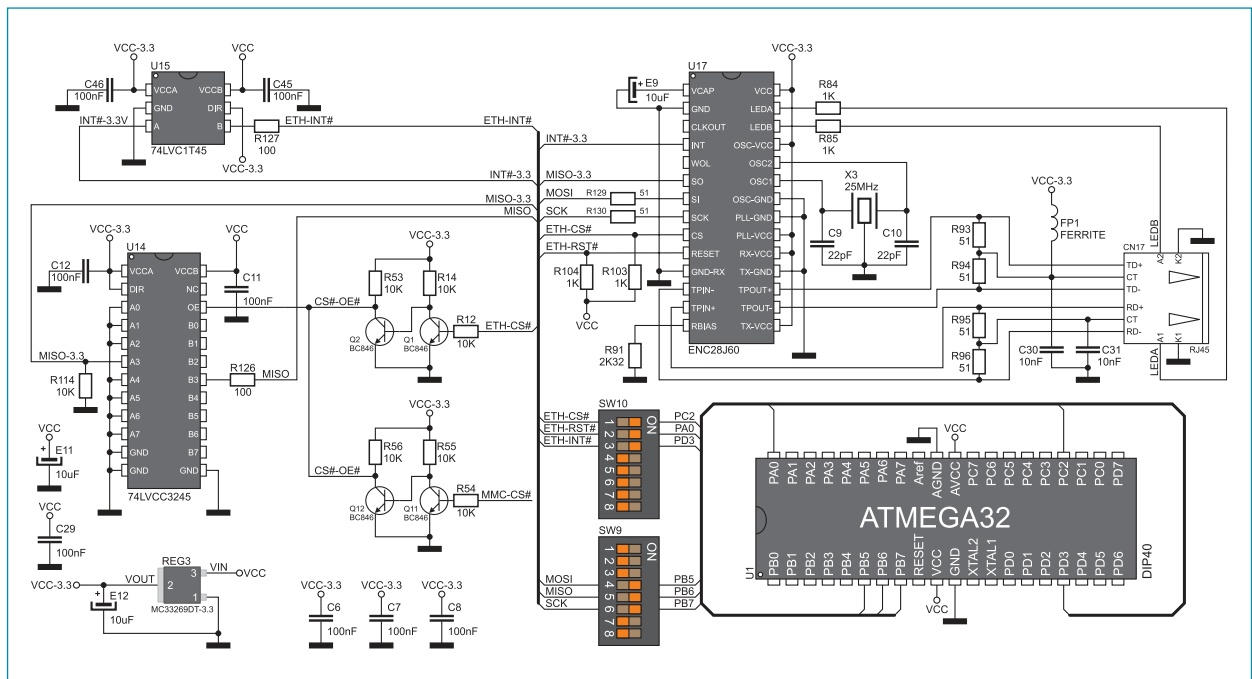

Figure 8-4: Ethernet module connection schematic

9.0. GSM module

The Telit's GSM/GPRS - GM862 module is connected to the development system via the GSM1 connector. Due to this module, the development system can communicate with remote devices through wireless GSM network. In addition to the GSM function, the development system may also use the Global Positioning System (GPS).

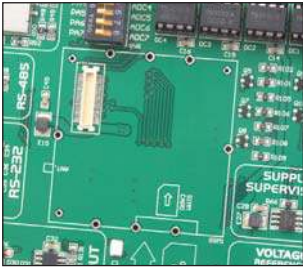

Figure 9-1: GSM connector

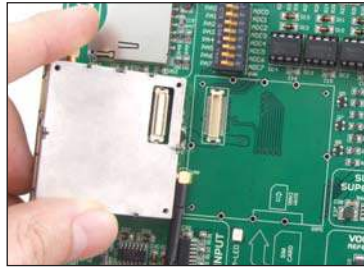

Figure 9-2: Connecting Telit's GM862 module

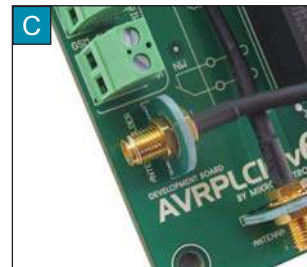
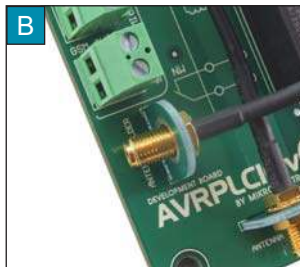

Figure 9-3: Telit's GM862 module

When the Telit's module is connected to the development system, it is necessary to screw cables in the appropriate holders on the development system, Figure 9-4.



Figure 9-4: Screwing cable into antenna holder



A Unscrew the nut from the screw provided on the cable

B Place the screw with cable into the antenna holder on the development system

C Screw the nut on the antenna terminal

When the cable is properly placed into the holder on the development system, it is necessary to screw antenna on the screw, Figure 9-5.



Figure 9-5: Connecting antenna



Figure 9-6: Telit's module with connected antennas

When all is properly set, it is necessary to insert a SIM card into the appropriate slot on the module. If the SIM card is not inserted, the development system will not be able to communicate to remote devices via wireless communication.

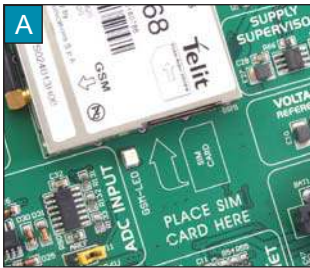

Figure 9-7: Inserting SIM card

The GSM module gives a possibility of making phone calls. To enable this function, it is necessary to connect a speaker to a screw terminal CN43 as well as a microphone to a screw terminal CN44. For more information refer to the Telit's GM862 datasheet. Calling number and other parameters referring to the GSM module are defined in the program loaded into the microcontroller.

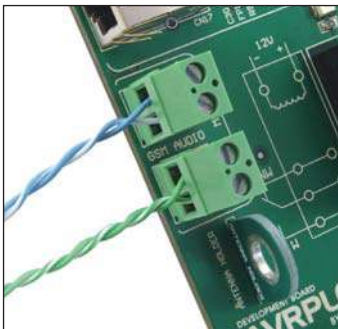

Figure 9-8: Connectors used to connect microphone and speaker

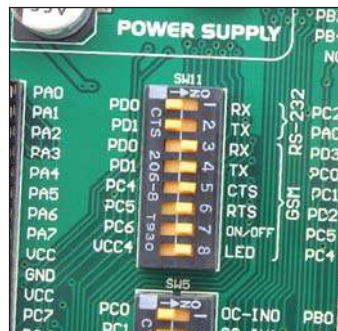

Figure 9-9: DIP switch SW11

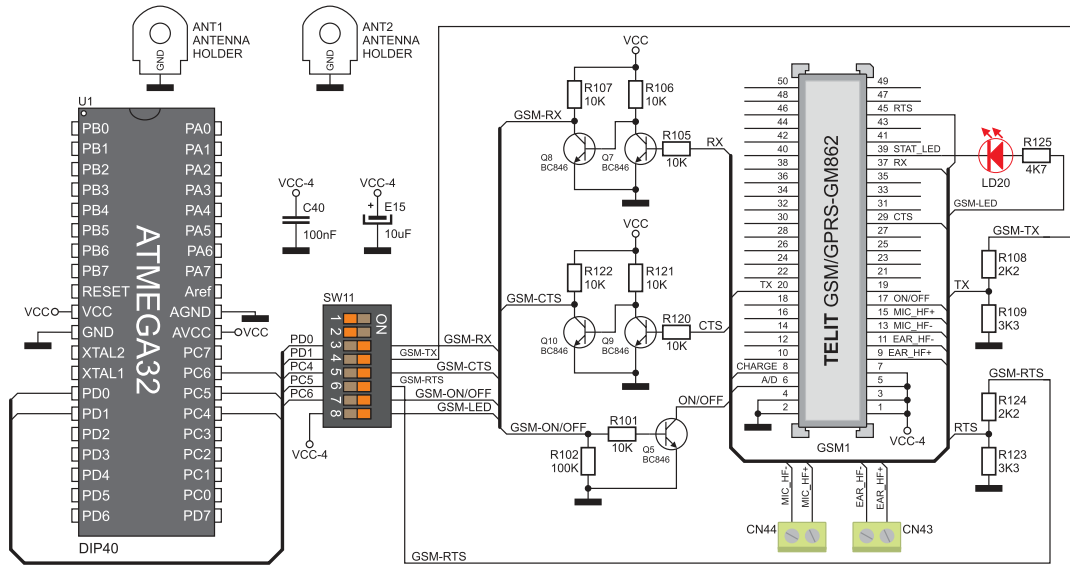

Figure 9-10: GSM module connection schematic

NOTE : Teltit's modules GM862-QUAD and GM862-GPS may be used with this development system.

10.0. RTC module

The RTC (Real-Time Clock) module on the development system is used to keep the real time, provide information on dates including correction for a leap year and months with less than 31 days. It can also serve as alarm, timer, for automatic power-fail detection, to generate interrupt at pre-set time and square wave voltage signals. This module has a battery backup and can operate even when the development system's power supply is off. The RTC module communicates with the microcontroller via I²C serial interface. In order to establish connection between them, it is necessary to set switches 4, 5 and 6 on the DIP switch SW10 to the ON position.

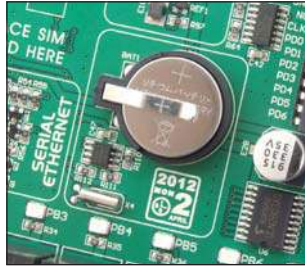

Figure 10-1: RTC module

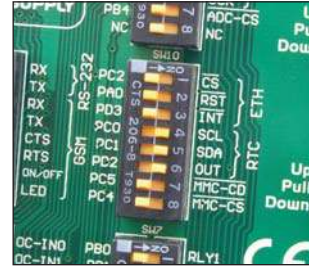

Figure 10-2: DIP switch SW10

Pins on the DS1307 circuit that are used for connection with the microcontroller are marked as follows:

- OUT - Square wave/output driver
- SCL - Serial clock input
- SDA - Serial data input/output

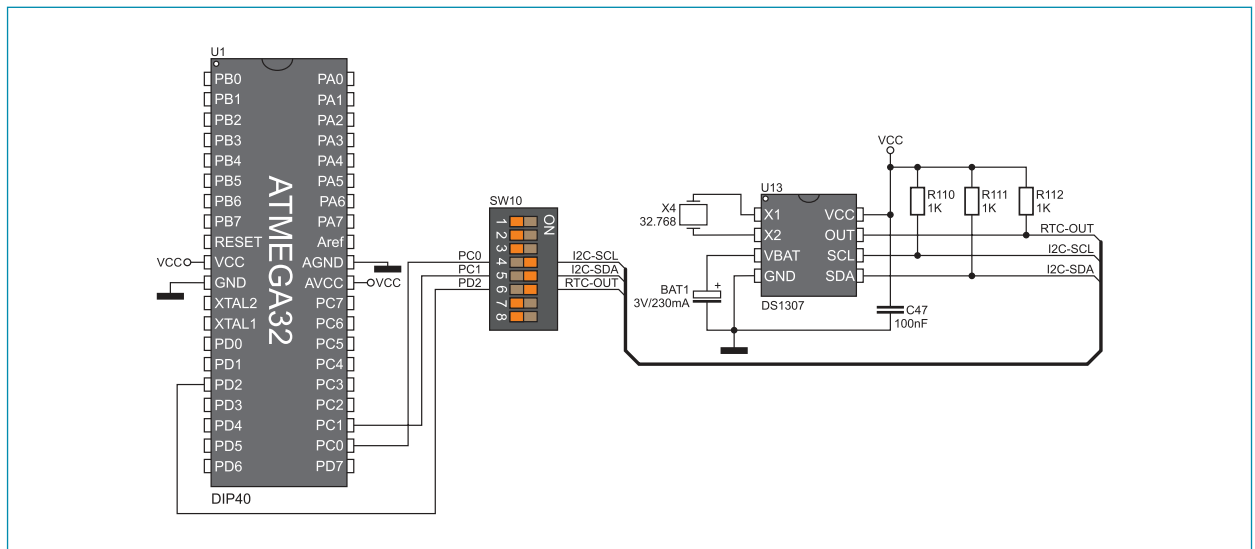

Figure 10-3: RTC module connection schematic

11.0. A/D inputs

In addition to the ADC module, A/D conversion may also be performed by the A/D module built into the microcontroller. The A/D module converts analog voltage signal in a range between 0 and 5V. The conversion of an analog signal into the appropriate digital number is performed in 10-bit resolution. In order to enable the A/D inputs, it is first necessary to set switches 1-8 on the DIP switch SW6 to the ON position.

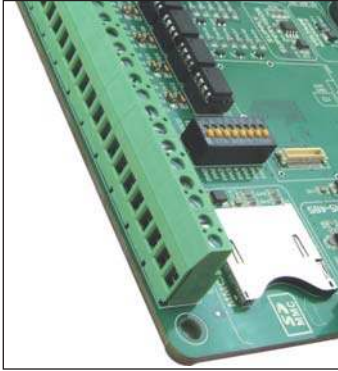

Figure 11-1: A/D inputs' connectors

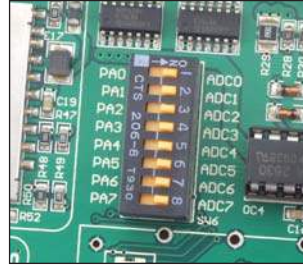

Figure 11-2: DIP switch SW6

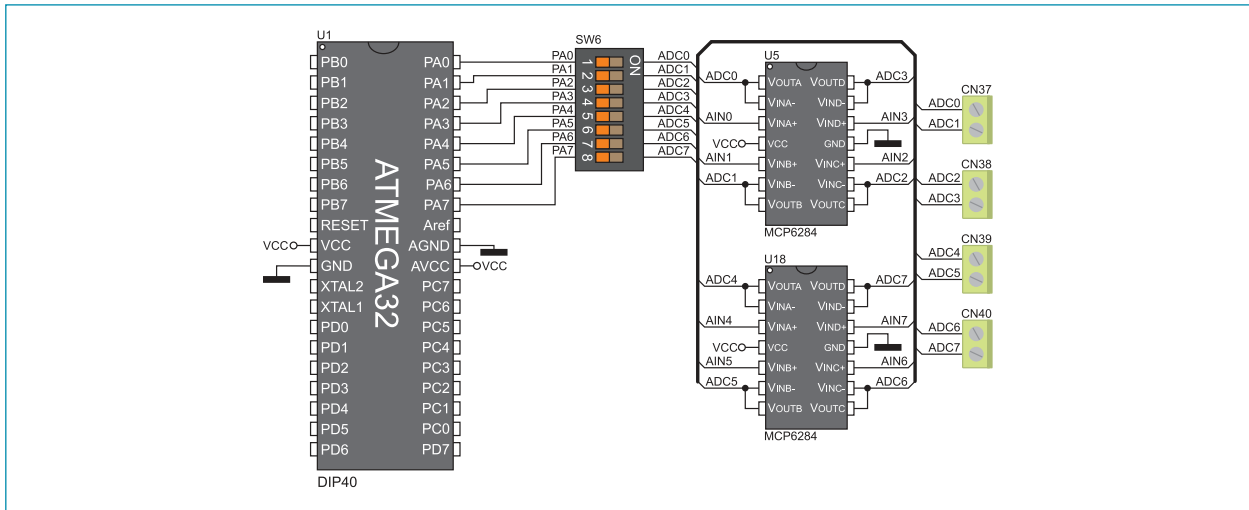

Figure 11-3: A/D inputs connection schematic

12.0. Relays and optocouplers

Industrial devices usually consume more power than the microcontroller can provide via its I/O ports. To enable the microcontroller to be connected to such devices, the development system is supplied with 16 relays by means of which it is possible to provide up to 250V power supply voltage. Each relay has one normally-open (W0, W1...) and one normally-closed (NW0, NW1...) contact. Sixteen relays are divided in four groups each consisting of four relays. Relays of one group are connected to one common contact. Accordingly, there are COMA, COMB, COMC and COMD common contacts. Figure 12-3 illustrates the connection between one group of relays and their common contact COMA. In addition to relays, the development system also features optocouplers whose function is to galvanically isolate signals supplied on the microcontroller inputs by industrial devices. As can be seen in Figure 12-3, the optocouplers are also connected to one common contact OCVCC.

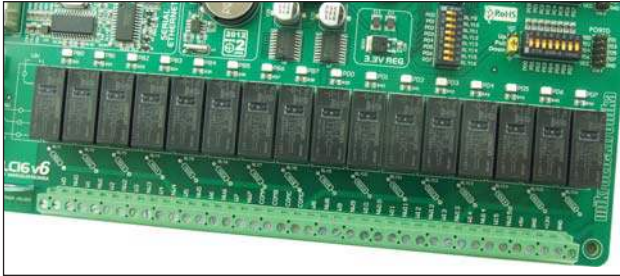

Figure 12-1: Relays with connectors

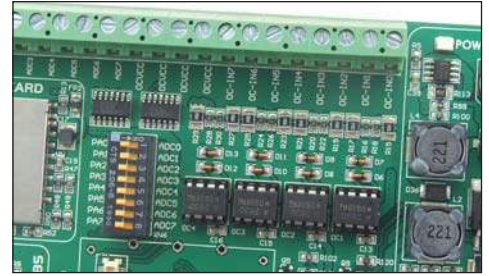

Figure 12-2: Optocouplers with connectors

In order to enable optocouplers' inputs, it is necessary to set switches 1-8 on the DIP switch SW5 to the ON position. To enable relays, it is necessary to set switches 1-8 on the DIP switches SW7 and SW8 to the ON position.

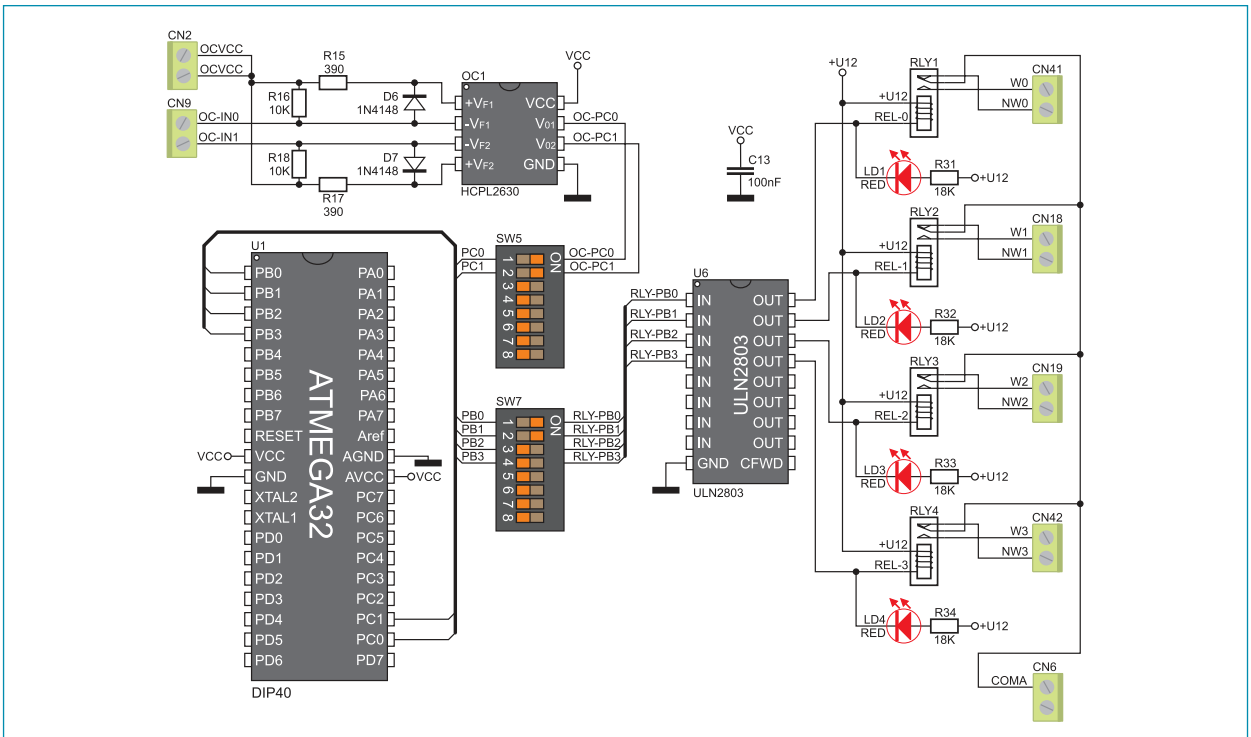

Figure 12-3: Relays and optocouplers and microcontroller connection schematic

13.0. Input/output ports

Along the right side of the development system, there are four 10-pin connectors linked to the microcontroller I/O ports. The microcontroller pins used for programming are not directly connected to the appropriate 10-pin connector, but via the multiplexer. DIP switches SW1-SW4 enable each connector pin to be connected to one pull-up/pull-down resistor. It depends on the position of jumpers J6-J9 whether the port pins are to be connected to pull-up or pull-down resistors.

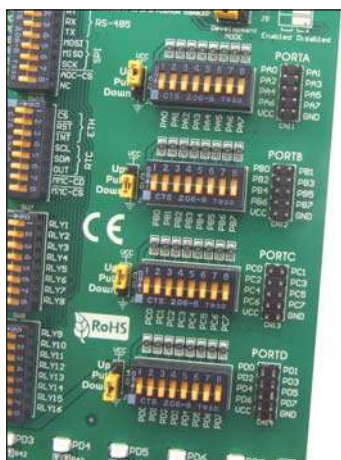

Figure 13-1: I/O ports



Figure 13-2: J2 in pull-down position



Figure 13-3: J2 in pull-up position

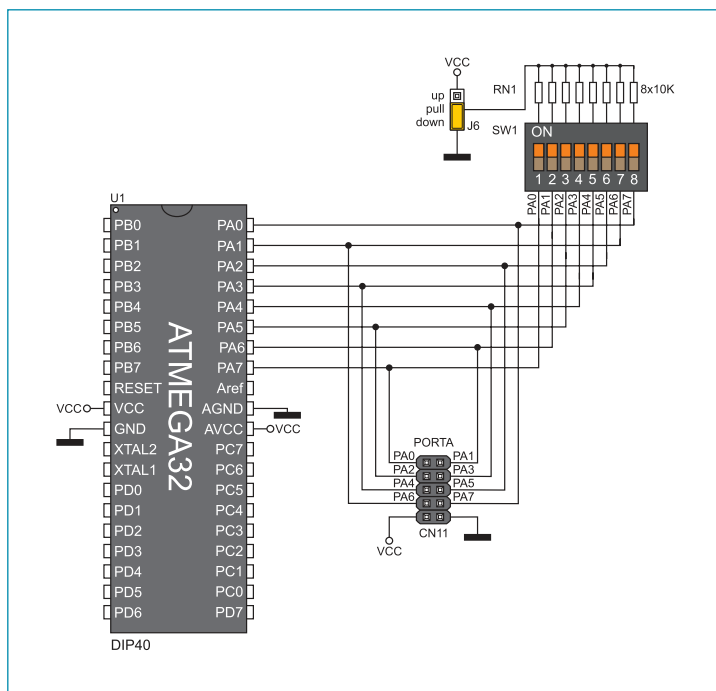

Figure 13-4: Port PORTA connection schematic

Pull-up/pull-down resistors enable you to set the logic level on all microcontroller input pins when they are in idle state. The logic level depends on the position of pull-up/pull-down jumpers. When this jumper is placed in the pull-up position, the input pins will be supplied with the 5V power supply voltage. In other words, these pins will be driven high (1). When this jumper is placed in the pull-down position, the input pins will be supplied with 0V, i.e. they will be fed with a logic zero (0).

In order to feed some of the input pins with desired logic level, it is necessary to enable connection between that pin and resistor using the appropriate DIP switch.

In Figure 13-4, the PORTA pins are driven low (0). It means that jumper J6 is placed in the pull-down position, whereas switches on the DIP switch SW2 are set to the ON position.

DISCLAIMER

All the products owned by MikroElektronika are protected by copyright law and international copyright treaty. Therefore, this manual is to be treated as any other copyright material. No part of this manual, including product and software described herein, may be reproduced, stored in a retrieval system, translated or transmitted in any form or by any means, without the prior written permission of MikroElektronika. The manual PDF edition can be printed for private or local use, but not for distribution. Any modification of this manual is prohibited.

MikroElektronika provides this manual 'as is' without warranty of any kind, either expressed or implied, including, but not limited to, the implied warranties or conditions of merchantability or fitness for a particular purpose.

MikroElektronika shall assume no responsibility or liability for any errors, omissions and inaccuracies that may appear in this manual. In no event shall MikroElektronika, its directors, officers, employees or distributors be liable for any indirect, specific, incidental or consequential damages (including damages for loss of business profits and business information, business interruption or any other pecuniary loss) arising out of the use of this manual or product, even if MikroElektronika has been advised of the possibility of such damages. MikroElektronika reserves the right to change information contained in this manual at any time without prior notice, if necessary.

HIGH RISK ACTIVITIES

The products of MikroElektronika are not fault – tolerant nor designed, manufactured or intended for use or resale as on – line control equipment in hazardous environments requiring fail – safe performance, such as in the operation of nuclear facilities, aircraft navigation or communication systems, air traffic control, direct life support machines or weapons systems in which the failure of Software could lead directly to death, personal injury or severe physical or environmental damage ('High Risk Activities'). MikroElektronika and its suppliers specifically disclaim any expressed or implied warranty of fitness for High Risk Activities.

TRADEMARKS

The Mikroelektronika name and logo, the Mikroelektronika logo, mikroC, mikroC PRO, mikroBasic, mikroBasic PRO, mikroPascal, mikroPascal PRO, AVRflash, PICflash, dsPICprog, 18FJprog, PSOCprog, AVRprog, 8051prog, ARMflash, EasyPIC5, EasyPIC6, BigPIC5, BigPIC6, dsPIC PRO4, Easy8051B, EasyARM, EasyAVR5, EasyAVR6, BigAVR2, EasydsPIC4A, EasyPSoC4, EasyVR Stamp LV18FJ, LV24-33A, LV32MX, PIC32MX4 MultiMedia Board, PICPLC16, PICPLC8 PICPLC4, SmartGSM/GPRS, UNI-DS are trademarks of Mikroelektronika. All other trademarks mentioned herein are property of their respective companies.

All other product and corporate names appearing in this manual may or may not be registered trademarks or copyrights of their respective companies, and are only used for identification or explanation and to the owners' benefit, with no intent to infringe.



MikroElektronika
SOFTWARE AND HARDWARE SOLUTIONS FOR EMBEDDED WORLD ...making it simple

If you want to learn more about our products, please visit our website at www.mikroe.com

If you are experiencing some problems with any of our products or just need additional information, please place your ticket at www.mikroe.com/en/support

If you have any questions, comments or business proposals, do not hesitate to contact us at office@mikroe.com