

THIS DRAWING IS UNPUBLISHED. RELEASED FOR PUBLICATION
 © COPYRIGHT ALL RIGHTS RESERVED.

LOC	DIST	REVISIONS			
P	LTR	DESCRIPTION	DATE	DWN	APVD
	D	HOUSING RIB STRENGTHENED AND RAWMATERIAL CHANGED TO PA4T	06JAN2012	PS	RRP
	E	ECO-16-001320	13JUN2016	AD	SH

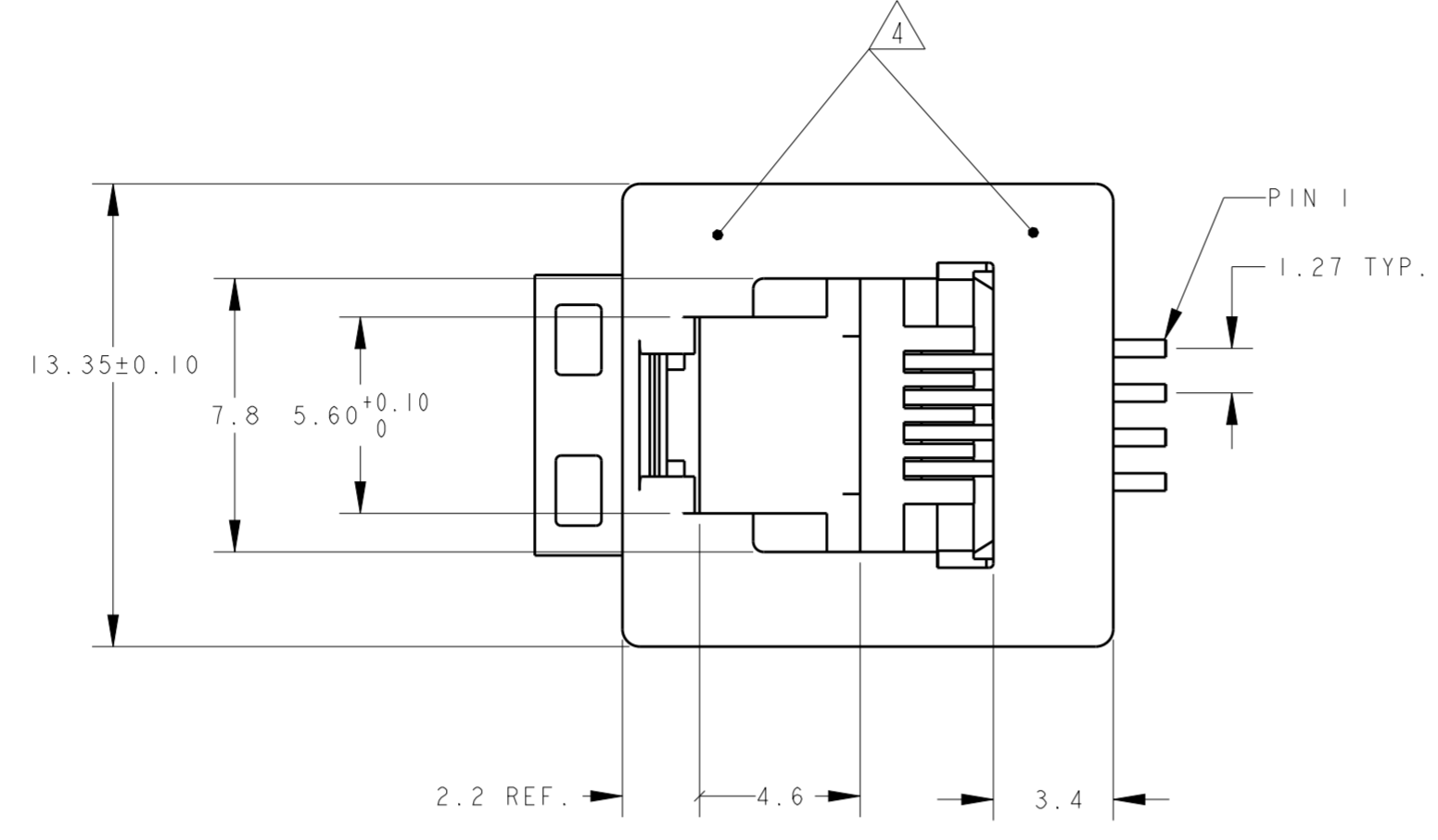
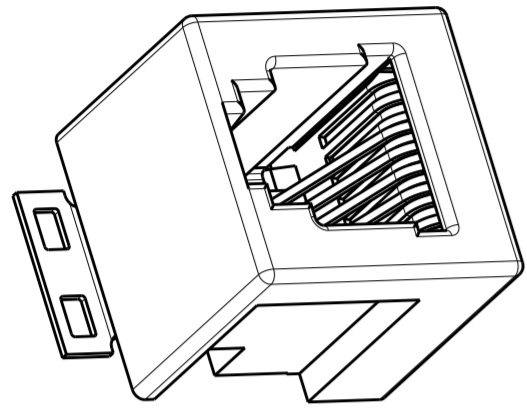

NOTES:

- 1 TOLERANCES UNLESS OTHERWISE SPECIFIED: ±0.15.
- 2 CONTACT PLATING:
 OVERALL: Ni 1.27µm MIN. ALL OVER THE CONTACTS
 SOLDER ZONE: Sn 3.5-5.0µm ON THE SOLDER ZONE OF THE CONTACT
 MATING ZONE: PLATING CONFIRMS TO PRODUCT REQUIREMENTS
 AS PER SPECIFICATION 108-19117
- 3 MATERIAL:
 HOUSING: 30% G.F. LCP, COLOR BLACK, UL 94V-0.
 CONTACTS: PHOSPHOR BRONZE
 SOLDER BRACKET: TINPLATED BRASS WITH NICKEL UNDERLAYER.
- 4 SURFACE CAN BE USED FOR PICKING THE MODULAR JACK WITH, TYPE 11 SMD MACHINE.
- 5 MEASURED AT HEEL OF CONTACTS, COPLANARITY AT TIPS MAX. 0.18mm.
- 6 TAPE AND REEL PACKAGING ACCORDING TO EIA 481-3 SPECIFICATIONS.

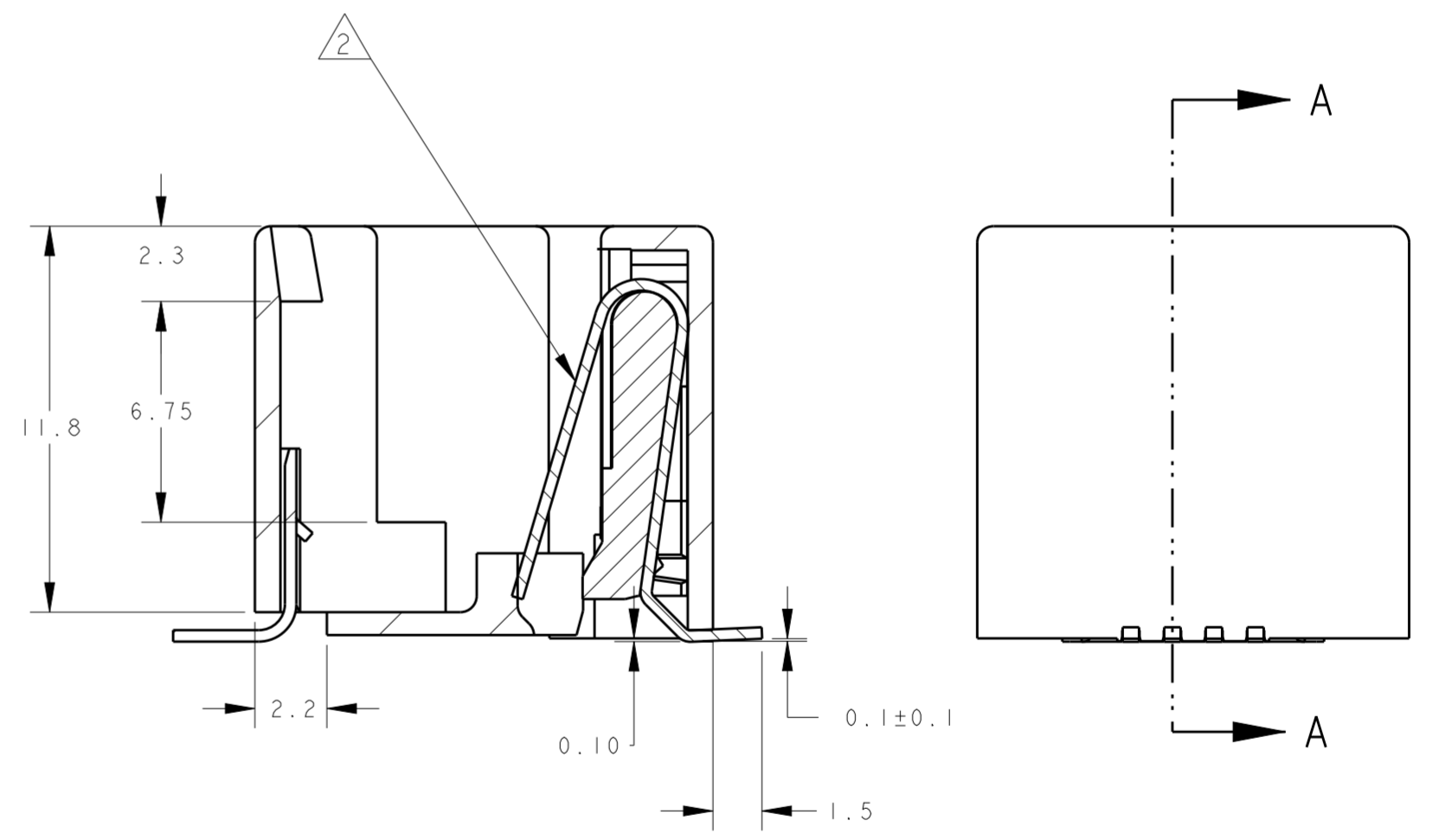
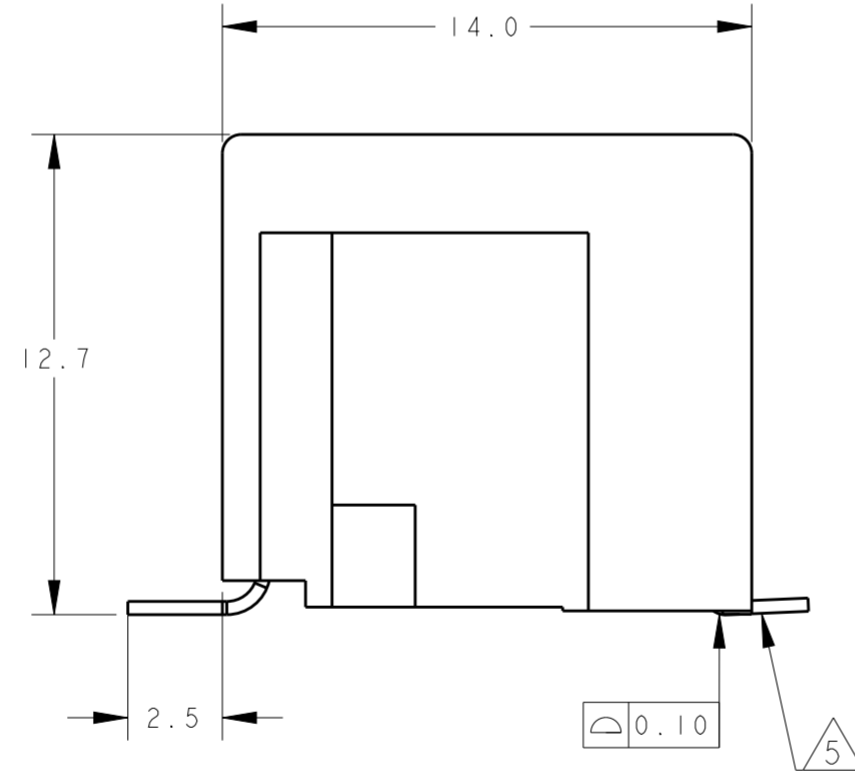
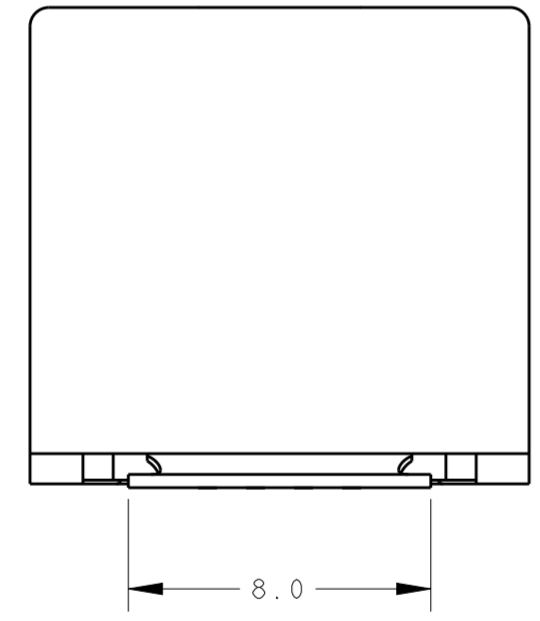

SECTION A-A

4 POS./4 CONT.	300 PCS ON Ø360 mm OD REEL. TOP ENTRY ORIENTATION PER DETAIL B	1857884-1
REMARKS	PACKAGING 6	PART NUMBER

THIS DRAWING IS A CONTROLLED DOCUMENT.		DWN Shrivathsa 14 Jul 06	STE TE Connectivity	
		CHK Premjith 14 Jul 06		
DIMENSIONS: mm	TOLERANCES UNLESS OTHERWISE SPECIFIED:	APVD M Oppers	NAME INVERTIBLE MODULAR JACK, 4 POSITION HANDSET SURFACE MOUNT APPLICATION	
0 PLC ±	1 PLC ±	PRODUCT SPEC 108-19117	SIZE A2	CAGE CODE G-1857884
2 PLC ±	3 PLC ±	APPLICATION SPEC 114-19041	DRAWING NO	RESTRICTED TO
4 PLC ±	ANGLES ±	WEIGHT 1.92 gr	SCALE 3:1	SHEET 1 OF 2
MATERIAL -	FINISH -	CUSTOMER DRAWING	REV E	
SEE NOTE 3	SEE NOTE 2			

THIS DRAWING IS UNPUBLISHED. RELEASED FOR PUBLICATION
 © COPYRIGHT ALL RIGHTS RESERVED.

LOC	DIST	REVISIONS			
P	LTR	DESCRIPTION	DATE	DWN	APVD
IR	-	SEE SHEET 1	-	-	-

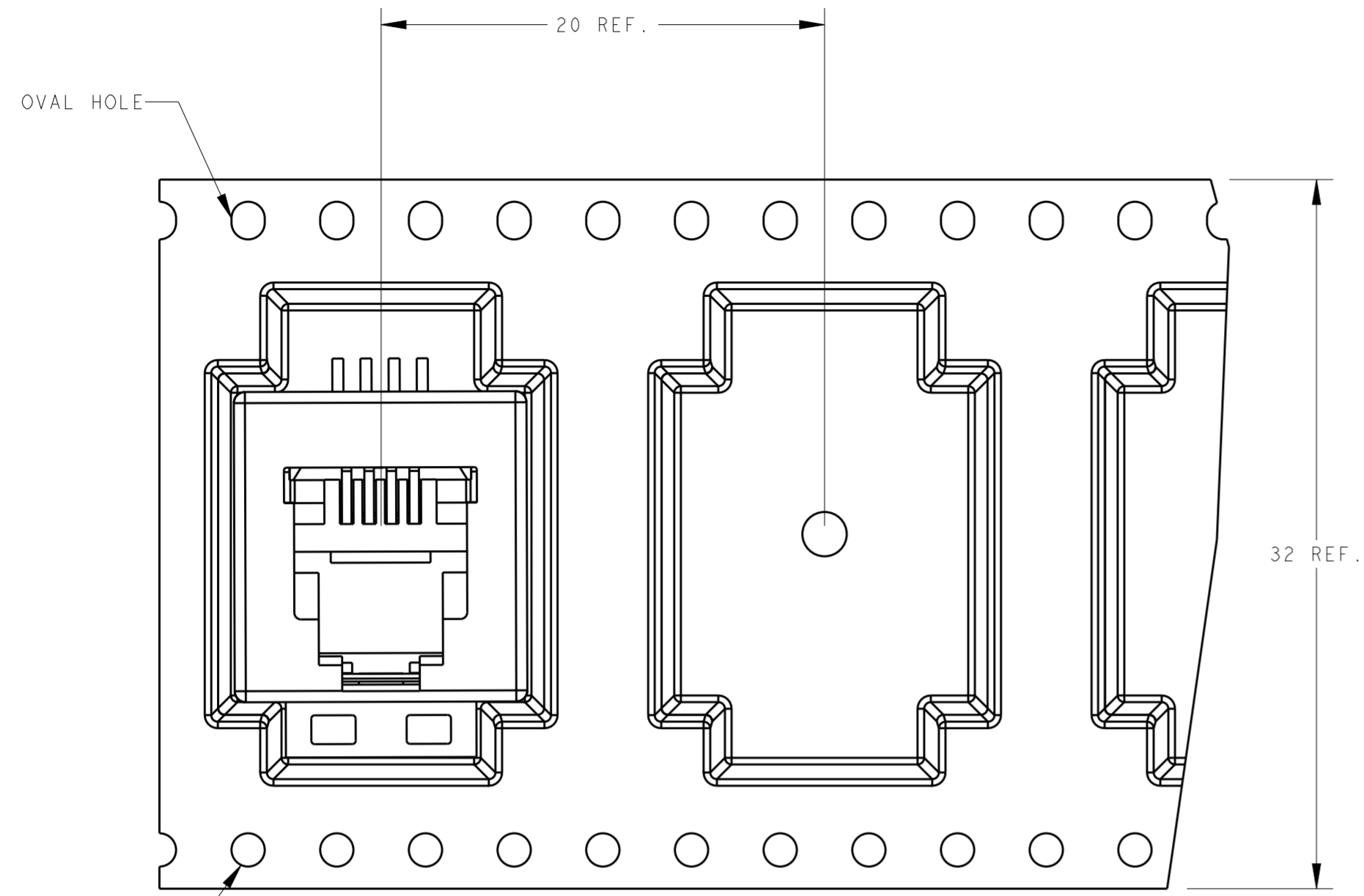

TOP ENTRY ORIENTATION.

DETAIL B
SCALE 4:1

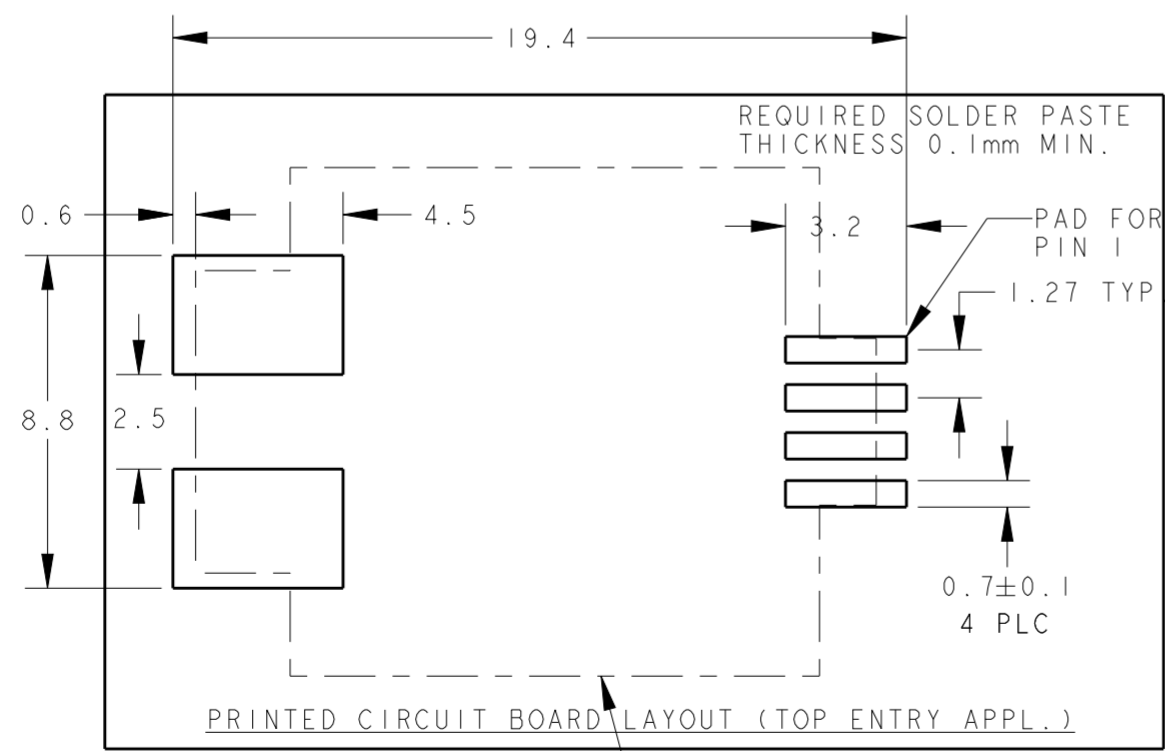
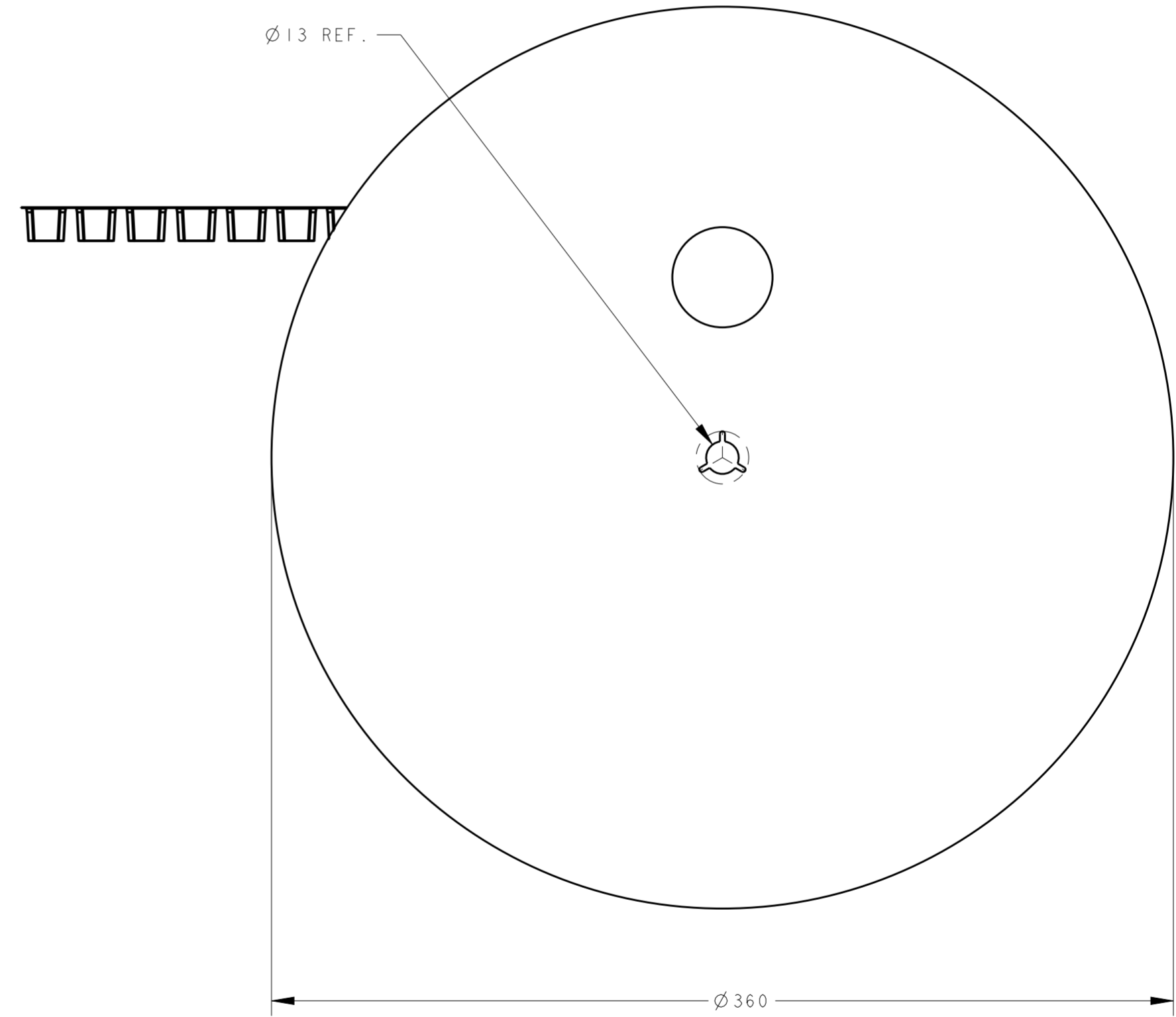
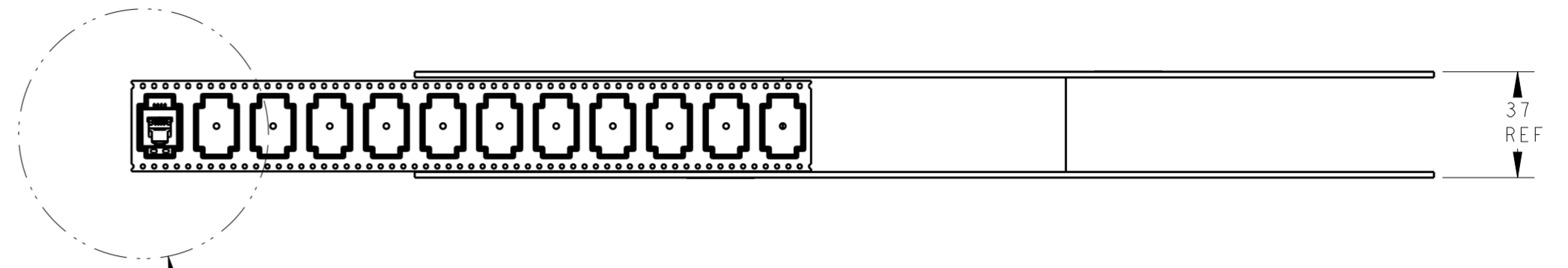

DASHLINE INDICATES OUTLINE OF JACK, CONTACTS AND BRACKET

THIS DRAWING IS A CONTROLLED DOCUMENT.		DWN Shrivathsa 14 Jul 06	STE TE Connectivity
		CHK Premjith 14 Jul 06	
DIMENSIONS: mm		APVD M Oppers	NAME INVERTIBLE MODULAR JACK, 4 POSITION HANDSET SURFACE MOUNT APPLICATION
TOLERANCES UNLESS OTHERWISE SPECIFIED:		PRODUCT SPEC	SIZE A2
0 PLC ±		APPLICATION SPEC	CAGE CODE
1 PLC ±			DRAWING NO C-1857884
2 PLC ±		WEIGHT	RESTRICTED TO
3 PLC ±			
4 PLC ±			
ANGLES ±		CUSTOMER DRAWING	SCALE 5:1
FINISH -			SHEET 2 OF 2
			REV E