

REVISONS		DATE	DMN	APVD
B4	ECR-08-012253	30-10-08	AEG	MKO
B5	ECR-10-003044	02JUN10	RK	MKG
B6	ECR-10-026542	27MAY11	KK	HMR

TERMINATION STYLES		L	CODE
SOLDER TERMINATIONS		2,9±0,3	01
		3,7±0,3	05
		4,5±0,3	02
WIRE WRAP TERMINATIONS AND SOLDER TERMINATION		6,3±0,3	03
		7,3±0,3	04
SOLDERING-HOOKS		13±0,5	40
		5,5±0,3	30
SOLDERING-LUGS		10-0,5	35
		5,5±0,3	
SOLDER BENDED OFF		3-0,4	10
		1,55-0,4	00

TERMINATION WITH GALVANIC SN PLATING

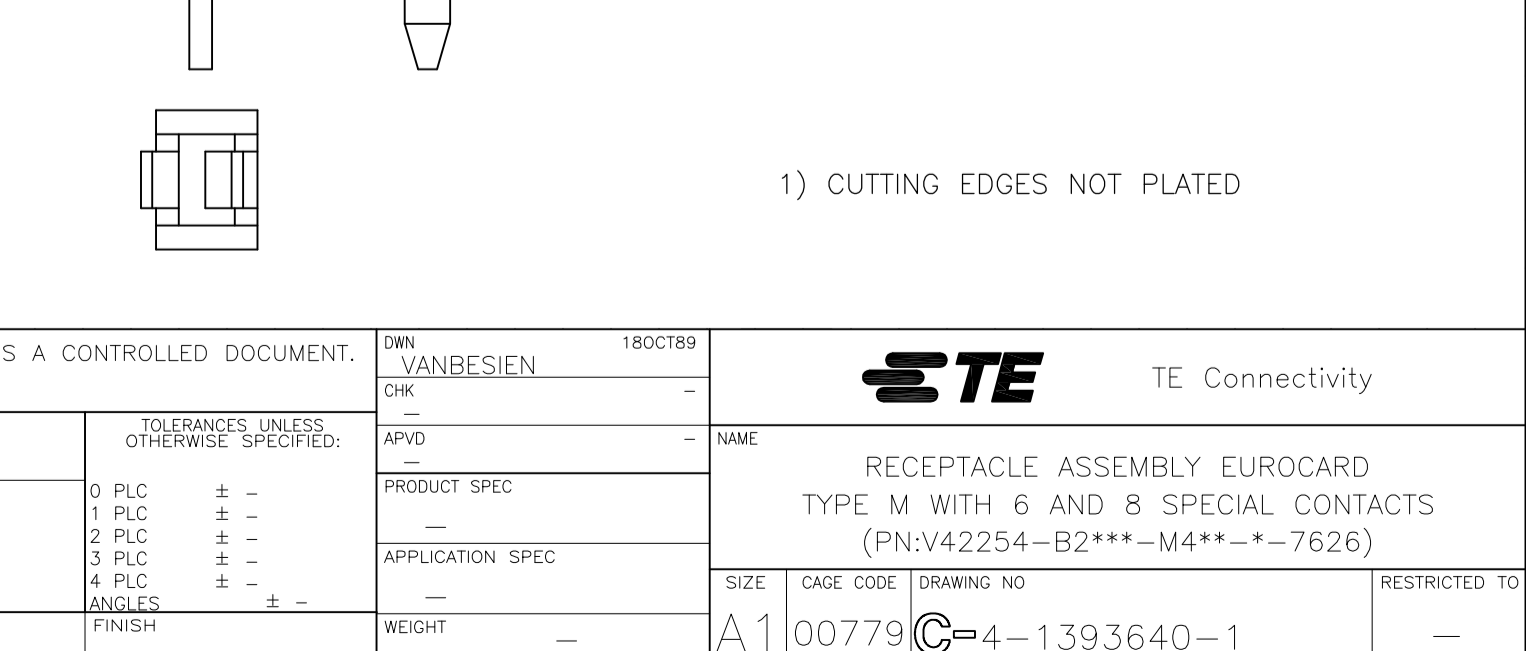
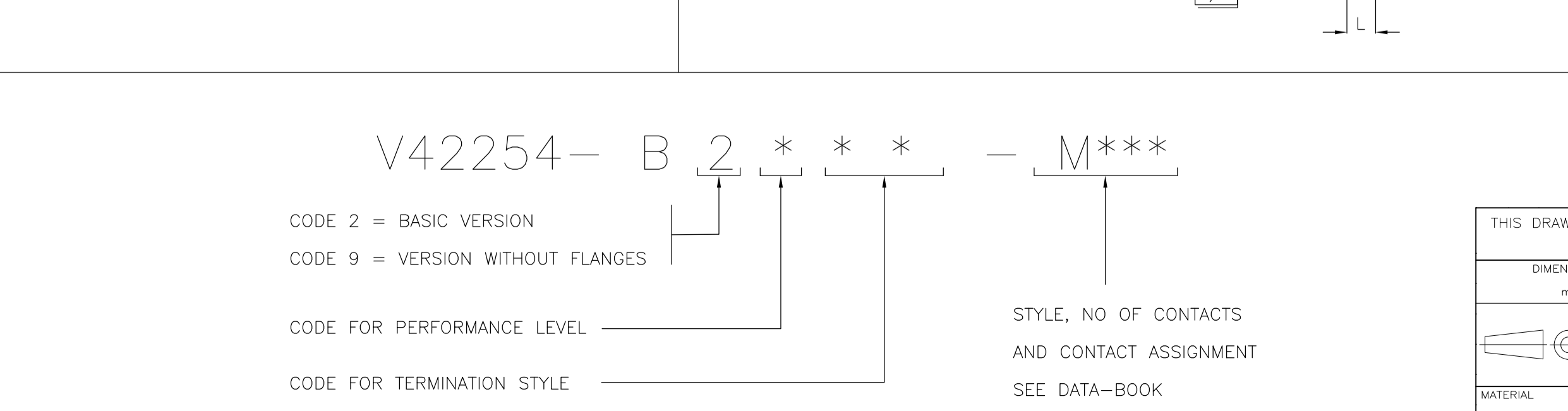
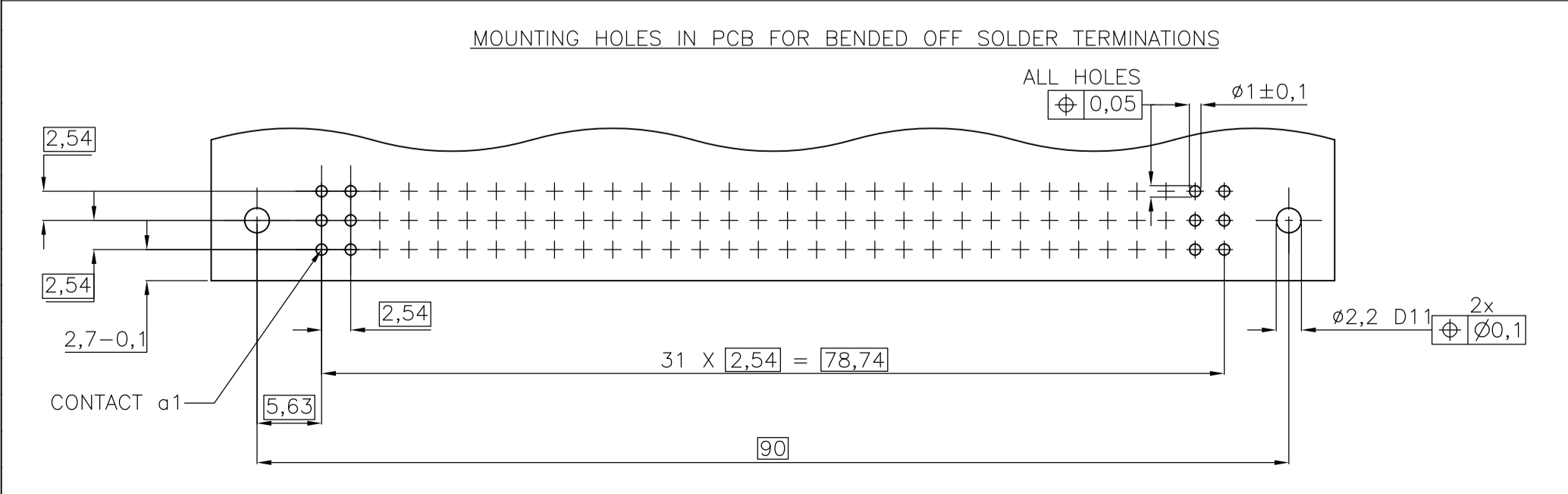
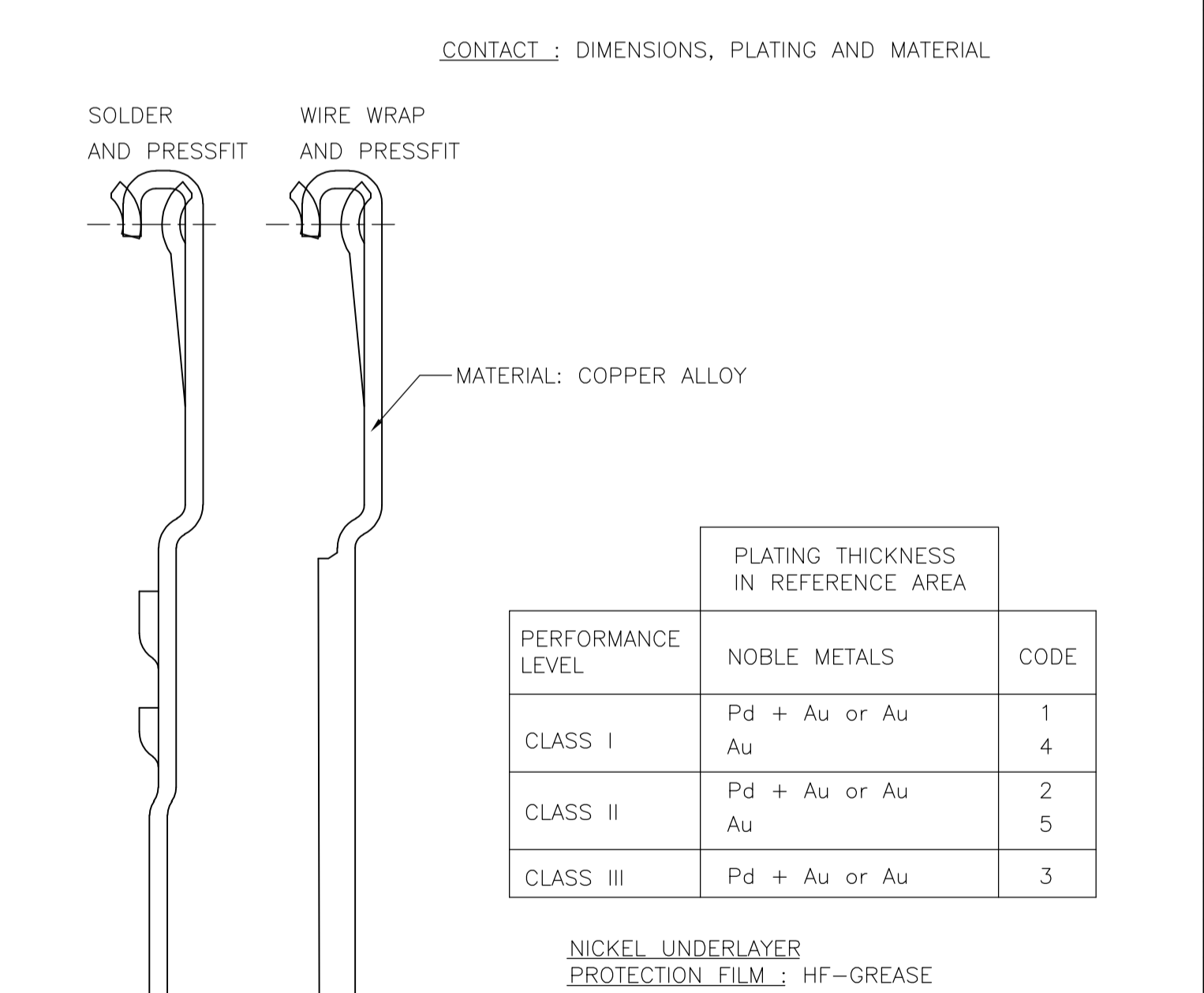
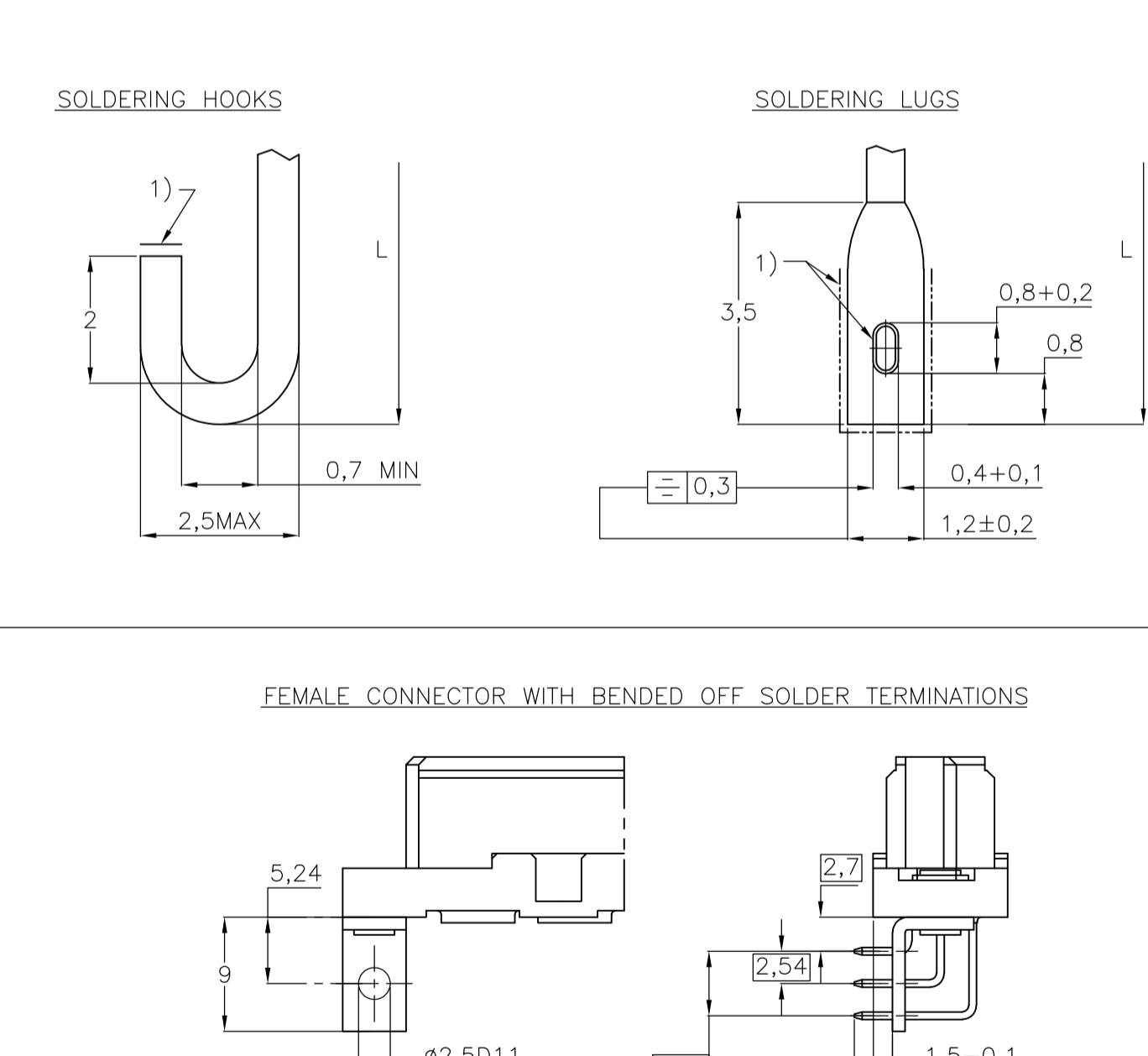
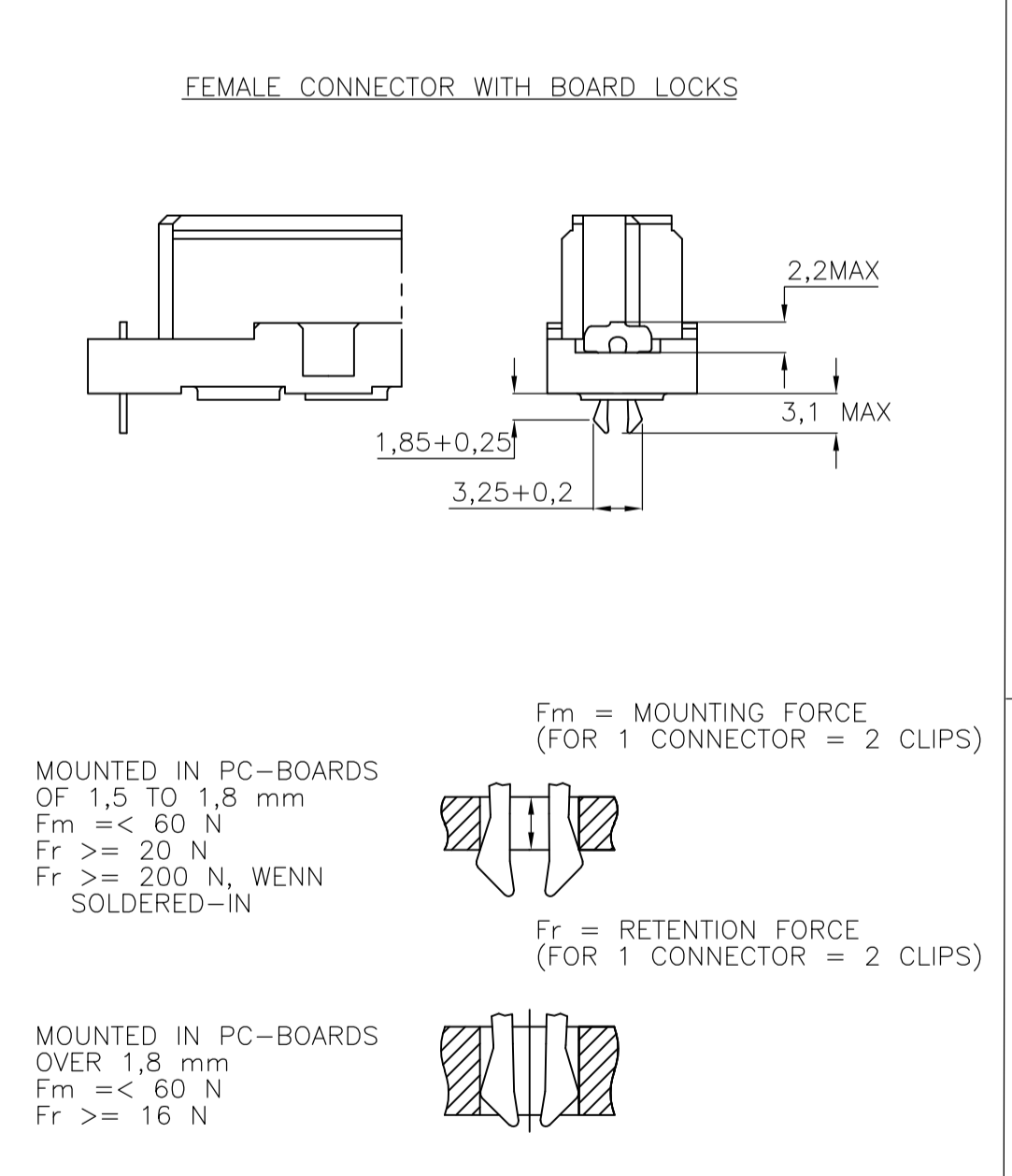
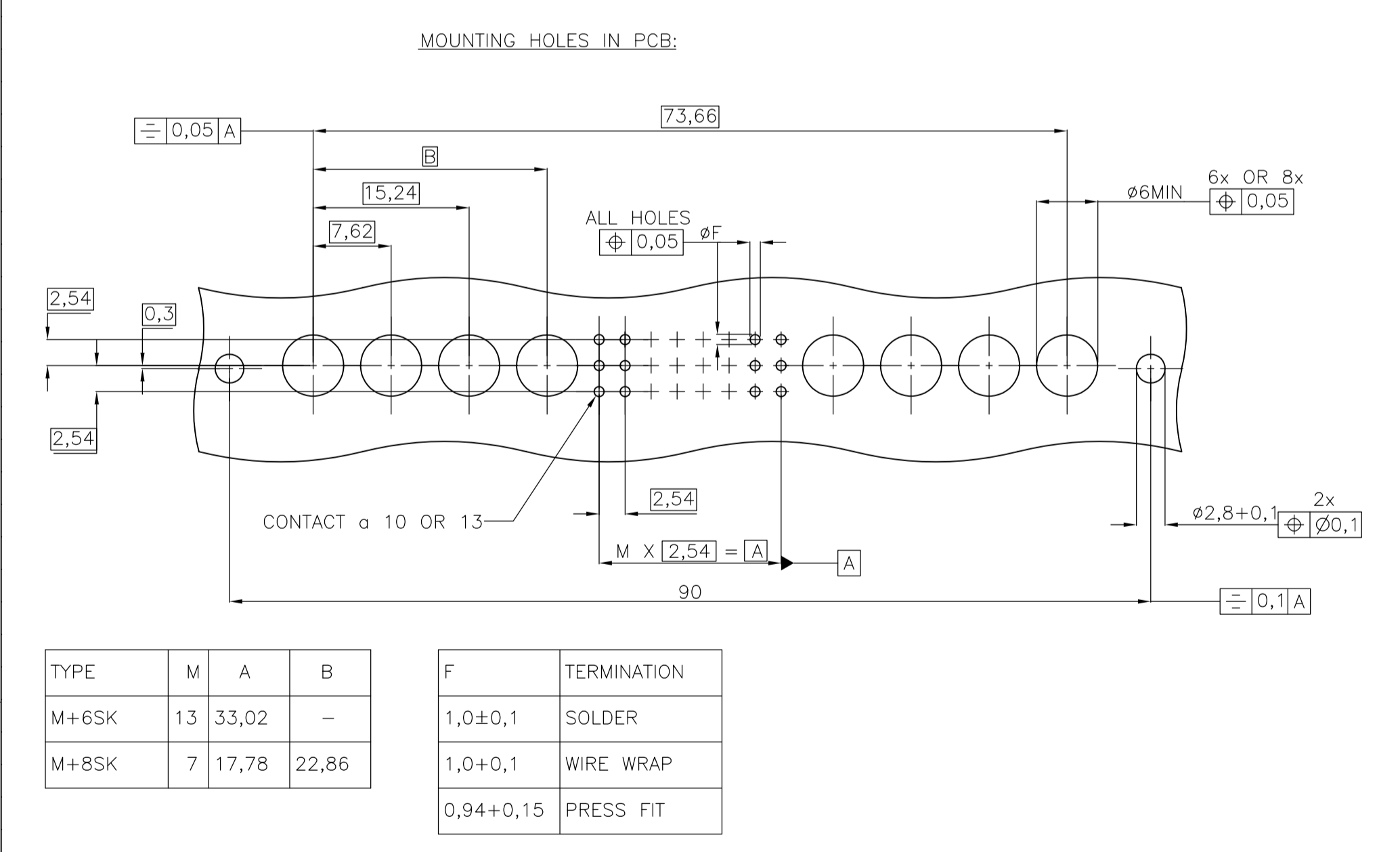

V42254 - B 2 * * * - M***

CODE 2 = BASIC VERSION
 CODE 9 = VERSION WITHOUT FLANGES
 CODE FOR PERFORMANCE LEVEL
 CODE FOR TERMINATION STYLE

STYLE, NO OF CONTACTS AND CONTACT ASSIGNMENT
 SEE DATA-BOOK

THIS DRAWING IS A CONTROLLED DOCUMENT.		DIN VANBESNIEN 180CT89	TE Connectivity	
DIMENSIONS: mm	TOLERANCES UNLESS OTHERWISE SPECIFIED:	APVD	NAME	RECEPTACLE ASSEMBLY EUROCARD
0 PLC ± -	1 PLC ± -	PRODUCT SPEC	TYPE M WITH 6 AND 8 SPECIAL CONTACTS	(PN:V42254-B2***-M4***-7626)
2 PLC ± -	3 PLC ± -	APPLICATION SPEC	SIZE	CAGE CODE DRAWING NO
4 PLC ± -	ANGLES ± -	WEIGHT	A1	00779
MATERIAL	FINISH	CUSTOMER DRAWING	SCALE	RESTRICTED TO
			NTS	1 OF 2

PRODUCT DESCRIPTION CODE	TE PN	STYLE & NUMBER OF POSITIONS	TERMINATION POSTS	LOADED ROWS	PERFORMANCE LEVEL	BOARD LOCKS
V42254-B2101-M420	1-1393640-3	M42+6	2,9MM STRAIGHT SOLDER LEADS	EVERY ROW , EVERY PITCH	1	NO OBSOLETE
V42254-B2110-M240	4-1393640-1	M24+8	RIGHT-ANGLE SOLDER LEADS WITH MOUNTING BRACKET	EVERY ROW , EVERY PITCH	1	NO OBSOLETE
V42254-B2110-M420	4-1393640-2	M42+6	RIGHT-ANGLE SOLDER LEADS WITH MOUNTING BRACKET	EVERY ROW , EVERY PITCH	1	NO
V42254-B2135-M240	5-1393640-3	M24+8	5,5 / 10MM SOLDER LUGS	EVERY ROW , EVERY PITCH	1	NO OBSOLETE
V42254-B2135-M420	5-1393640-4	M42+6	5,5 / 10MM SOLDER LUGS	EVERY ROW , EVERY PITCH	1	NO OBSOLETE
V42254-B2140-M240	6-1393640-4	M24+8	13MM STRAIGHT WIRE-WRAP PINS	EVERY ROW , EVERY PITCH	1	NO OBSOLETE
V42254-B2140-M420	6-1393640-5	M42+6	13MM STRAIGHT WIRE-WRAP PINS	EVERY ROW , EVERY PITCH	1	NO OBSOLETE
V42254-B2201-M240	9-1393640-7	M24+8	2,9MM STRAIGHT SOLDER LEADS	EVERY ROW , EVERY PITCH	2	NO OBSOLETE
V42254-B2201-M410	9-1393640-9	M42+6	2,9MM STRAIGHT SOLDER LEADS	EVERY ROW , EVERY PITCH	2	YES OBSOLETE
V42254-B2201-M420	1393641-1	M42+6	2,9MM STRAIGHT SOLDER LEADS	EVERY ROW , EVERY PITCH	2	NO OBSOLETE
V42254-B2201-M423	1393641-2	M42+6	2,9MM STRAIGHT SOLDER LEADS	ROW A+C , EVERY PITCH	2	NO OBSOLETE
V42254-B2202-M240	4-1393641-2	M24+8	4,5MM STRAIGHT SOLDER LEADS	EVERY ROW , EVERY PITCH	2	NO OBSOLETE
V42254-B2202-M420	4-1393641-4	M42+6	4,5MM STRAIGHT SOLDER LEADS	EVERY ROW , EVERY PITCH	2	NO OBSOLETE
V42254-B2202-M420B	4-1393641-5	M42+6	4,5MM STRAIGHT SOLDER LEADS	EVERY ROW , EVERY PITCH	2	NO OBSOLETE
V42254-B2203-M240	6-1393641-0	M24+8	6,3MM STRAIGHT SOLDER LEADS	EVERY ROW , EVERY PITCH	2	NO OBSOLETE
V42254-B2240-M240	2-1393642-3	M24+8	13MM STRAIGHT WIRE-WRAP PINS	EVERY ROW , EVERY PITCH	2	NO OBSOLETE
V42254-B2240-M420	2-1393642-5	M42+6	13MM STRAIGHT WIRE-WRAP PINS	EVERY ROW , EVERY PITCH	2	NO OBSOLETE

1)

1) ACCORDING TO BT 236 LEVEL 2.

ACTIVE PART NUMBERS.
CONTACT TYCO ELECTRONICS FOR OTHER CONFIGURATION AVAILABILITY

THIS DRAWING IS A CONTROLLED DOCUMENT.		DIN 180CT89	VANBESJEN	
DIMENSIONS: mm		TOLERANCES UNLESS OTHERWISE SPECIFIED:	STE TE Connectivity	
		0 PLC ± -	RECEPTACLE ASSEMBLY EUROCARD	
		1 PLC ± -	TYPE M WITH 6 AND 8 SPECIAL CONTACTS	
		2 PLC ± -	(PN:V42254-B2***-M4***-7626)	
		3 PLC ± -	APPLICATION SPEC	
		4 PLC ± -	SIZE A1	
		ANGLES ± -	CAGE CODE 4-1393640-1	
MATERIAL		FINISH	WEIGHT	
			CUSTOMER DRAWING	
			SCALE NTS SHEET 2 OF 2 REV B6	