

9348 12-Input Parity Checker/Generator

General Description

The 9348 is a 12-input parity checker/generator generating odd and even parity outputs. It can be used in high speed error detection applications.

Connection Diagram

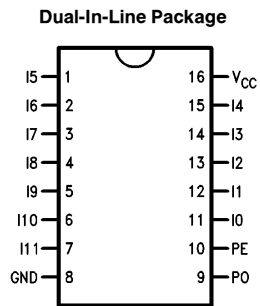

TL/F/9795-1

Order Number 9348DMQB or 9348FMQB
See NS Package Number J16A or W16A

Logic Symbol

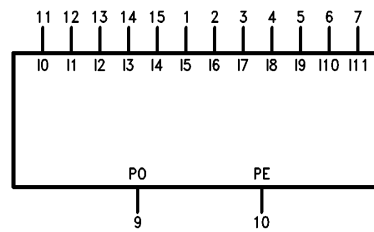

V_{CC} = Pin 16
 GND = Pin 8

TL/F/9795-2

Pin Names	Description
I0-I11	Parity Inputs
PO	Odd Parity Output
PE	Even Parity Output

Absolute Maximum Ratings

If Military/Aerospace specified devices are required, please contact the National Semiconductor Sales Office/Distributors for availability and specifications.

Supply Voltage	7V
Input Voltage	5.5V
Operating Free Air Temperature Range	
Military	–55°C to +125°C
Storage Temperature Range	–65°C to +150°C

Note: The “Absolute Maximum Ratings” are those values beyond which the safety of the device cannot be guaranteed. The device should not be operated at these limits. The parametric values defined in the “Electrical Characteristics” table are not guaranteed at the absolute maximum ratings. The “Recommended Operating Conditions” table will define the conditions for actual device operation.

Recommended Operating Conditions

Symbol	Parameter	9348			Units
		Min	Nom	Max	
V _{CC}	Supply Voltage	4.5	5	5.5	V
V _{IH}	High Level Input Voltage	2			V
V _{IL}	Low Level Input Voltage			0.8	V
I _{OH}	High Level Output Current			–0.8	mA
I _{OL}	Low Level Output Current			16	mA
T _A	Free Air Operating Temperature	–55		125	°C

Electrical Characteristics

Over recommended operating free air temperature range (unless otherwise noted)

Symbol	Parameter	Conditions	Min	Typ (Note 1)	Max	Units
V _I	Input Clamp Voltage	V _{CC} = Min, I _I = –12 mA			–1.5	V
V _{OH}	High Level Output Voltage	V _{CC} = Min, I _{OH} = Max, V _{IL} = Max	2.4			V
V _{OL}	Low Level Output Voltage	V _{CC} = Min, I _{OL} = Max, V _{IH} = Min			0.4	V
I _I	Input Current @ Max Input Voltage	V _{CC} = Max, V _I = 5.5V			1	mA
I _{IH}	High Level Input Current	V _{CC} = Max, V _I = 2.4V			80	μA
I _{IL}	Low Level Input Current	V _{CC} = Max, V _I = 0.4V			–3.2	mA
I _{OS}	Short Circuit Output Current	V _{CC} = Max (Note 2)	–20		–70	mA
I _{CC}	Supply Current	V _{CC} = Max			82	mA

Note 1: All typicals are at V_{CC} = 5V, T_A = 25°C.

Note 2: Not more than one output should be shorted at a time.

Switching Characteristics

V_{CC} = +5.0V, T_A = +25°C (See Section 1 for waveforms and load configuration)

Symbol	Parameter	Conditions	C _L = 15 pF R _L = 400Ω		Units
			Min	Max	
t _{PLH} t _{PHL}	Propagation Delay I4 to PO	I2, I3, I7, I8 = GND; Other Inputs (except I4) HIGH		46 42	ns
t _{PLH} t _{PHL}	Propagation Delay I4 to PE	I2, I3, I7, I8 = GND; Other Inputs (except I4) HIGH		51 48	ns
t _{PLH}	Propagation Delay I3 to PO	I7 = HIGH; Other Inputs (except I3) = GND		27	ns
t _{PHL}	Propagation Delay I4 to PO	All Inputs (except I4) = GND		25	ns

Functional Description

The 9348 is a 12-input parity generator. It provides odd and even parity for up to 12 data bits. The Even Parity output (PE) will be HIGH if an even number of logic ones are present on the inputs. The Odd Parity output (PO) will be HIGH if an odd number of logic ones are present on the inputs. The logic equations for the outputs are shown below.

$$PO = I_0 \oplus I_1 \oplus I_2 \oplus I_3 \oplus I_4 \oplus I_5 \oplus I_6 \oplus I_7 \oplus I_8 \oplus I_9 \oplus I_{10} \oplus I_{11}$$

$$PE = I_0 \oplus I_1 \oplus I_2 \oplus I_3 \oplus I_4 \oplus I_5 \oplus I_6 \oplus I_7 \oplus I_8 \oplus I_9 \oplus I_{10} \oplus I_{11}$$

Note: Less through delay is encountered from the I₀, I₁, I₂ and I₃ inputs than I₄ thru I₁₁ inputs. Therefore, if some signals are slower than others, the slower signals should be applied to these four inputs for maximum speed.

Truth Table

Inputs		Outputs	
I ₀ -I ₁₁		PO	PE
All Twelve	Inputs LOW	L	H
Any One	Inputs HIGH	H	L
Any Two	Inputs HIGH	L	H
Any Three	Inputs HIGH	H	L
Any Four	Inputs HIGH	L	H
Any Five	Inputs HIGH	H	L
Any Six	Inputs HIGH	L	H
Any Seven	Inputs HIGH	H	L
Any Eight	Inputs HIGH	L	H
Any Nine	Inputs HIGH	H	L
Any Ten	Inputs HIGH	L	H
Any Eleven	Inputs HIGH	H	L
Any Twelve	Inputs HIGH	L	H

H = HIGH Voltage Level
L = LOW Voltage Level

Logic Diagram

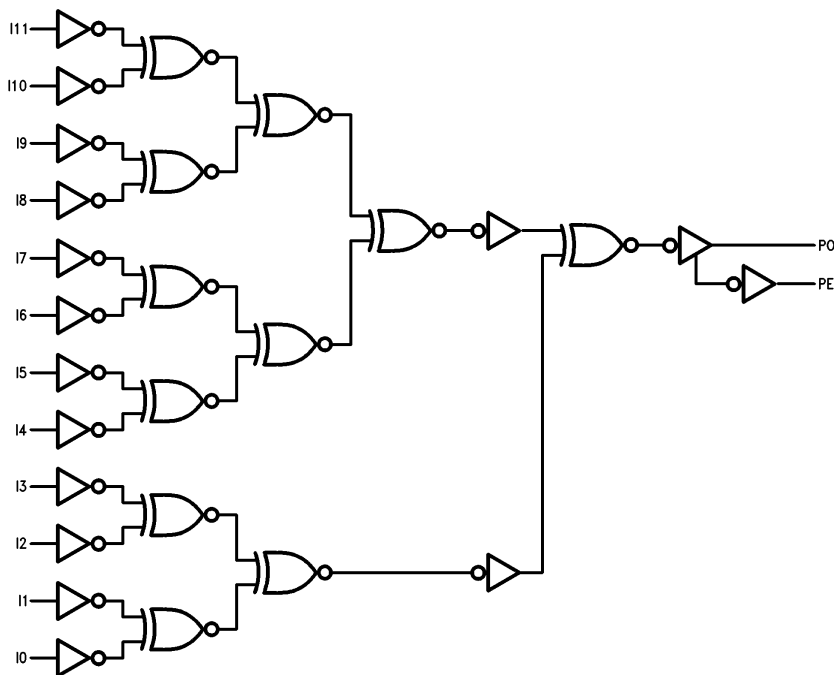

TL/F/9795-3

Physical Dimensions inches (millimeters)

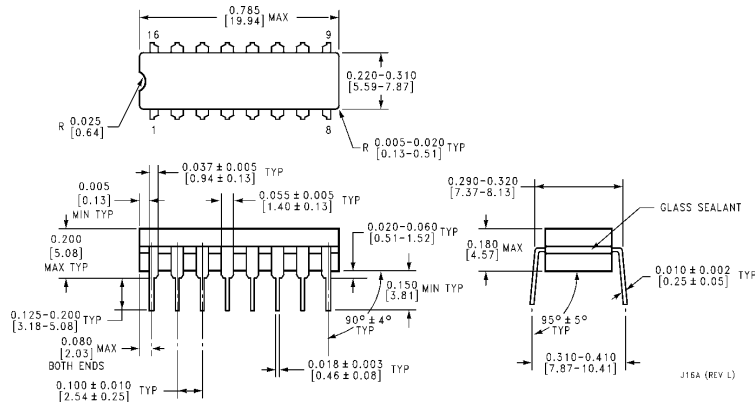

16-Lead Ceramic Dual-In-Line Package (J)
Order Number 9348DMQB
NS Package Number J16A

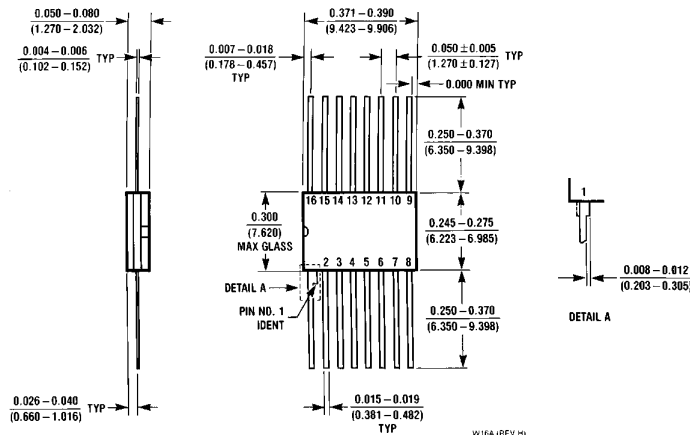

16-Lead Ceramic Flat Package (W)
Order Number 9348FMQB
NS Package Number W16A

LIFE SUPPORT POLICY

NATIONAL'S PRODUCTS ARE NOT AUTHORIZED FOR USE AS CRITICAL COMPONENTS IN LIFE SUPPORT DEVICES OR SYSTEMS WITHOUT THE EXPRESS WRITTEN APPROVAL OF THE PRESIDENT OF NATIONAL SEMICONDUCTOR CORPORATION. As used herein:

1. Life support devices or systems are devices or systems which, (a) are intended for surgical implant into the body, or (b) support or sustain life, and whose failure to perform, when properly used in accordance with instructions for use provided in the labeling, can be reasonably expected to result in a significant injury to the user.
2. A critical component is any component of a life support device or system whose failure to perform can be reasonably expected to cause the failure of the life support device or system, or to affect its safety or effectiveness.



National Semiconductor Corporation
 1111 West Bardin Road
 Arlington, TX 76017
 Tel: 1(800) 272-9959
 Fax: 1(800) 737-7018

National Semiconductor Europe
 Fax: (+49) 0-180-530 85 86
 Email: cnjwge@tevm2.nsc.com
 Deutsch Tel: (+49) 0-180-530 85 85
 English Tel: (+49) 0-180-532 78 32
 Français Tel: (+49) 0-180-532 93 58
 Italiano Tel: (+49) 0-180-534 16 80

National Semiconductor Hong Kong Ltd.
 19th Floor, Straight Block,
 Ocean Centre, 5 Canton Rd.
 Tsimshatsui, Kowloon
 Hong Kong
 Tel: (852) 2737-1600
 Fax: (852) 2736-9960

National Semiconductor Japan Ltd.
 Tel: 81-043-299-2309
 Fax: 81-043-299-2408

National does not assume any responsibility for use of any circuitry described, no circuit patent licenses are implied and National reserves the right at any time without notice to change said circuitry and specifications.