

THIS DRAWING IS UNPUBLISHED. RELEASED FOR PUBLICATION 20  
 © COPYRIGHT 20 BY - ALL RIGHTS RESERVED.

REVISIONS					
P	LTR	DESCRIPTION	DATE	DWN	APVD
	D4	REVISED PER ECR-19-017851	28NOV2019	SM	DZ

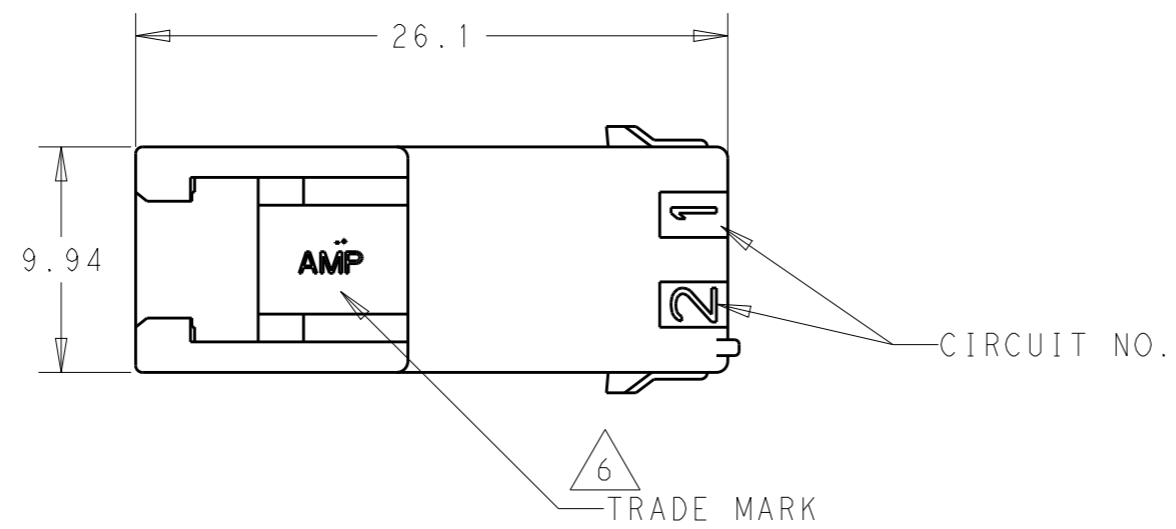

- NOTES:
- 1 APPLICABLE CONTACT P/N  
 TAB CONTACT: 177917-□ (#20-#16AWG)  
 177916-□ (#26-#22AWG)
  - 2 MATING CONN. P/N  
 PLUG HSG: 177898-□  
 REC CONTACT: 177915-□ (#20-#16AWG)  
 177914-□ (#26-#22AWG)
  - 3 APPLICABLE PLATE P/N: 177918-□
  - 4 INSTRUCTION SHEET: 411-5638
  - 5 SEE TABLE 1
  - 6 ALL PARTS MEET RTI ELECTRICAL RATING OF 150C ACCORDING TO UL 1977.
  - 7 PART 5-179463-1 COMPLY WITH GLOW WIRE REQUIREMENT FOR PARTS OF NON-METALLIC MATERIAL SUPPORTING A CURRENT-CARRYING CONNECTION DETAILED IN IEC 60335-1, SECTION 30(GWT)

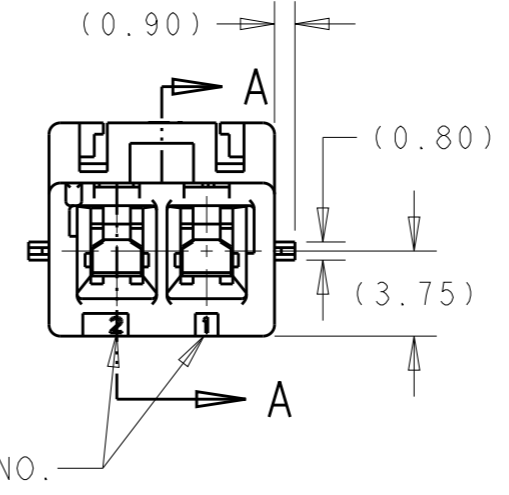
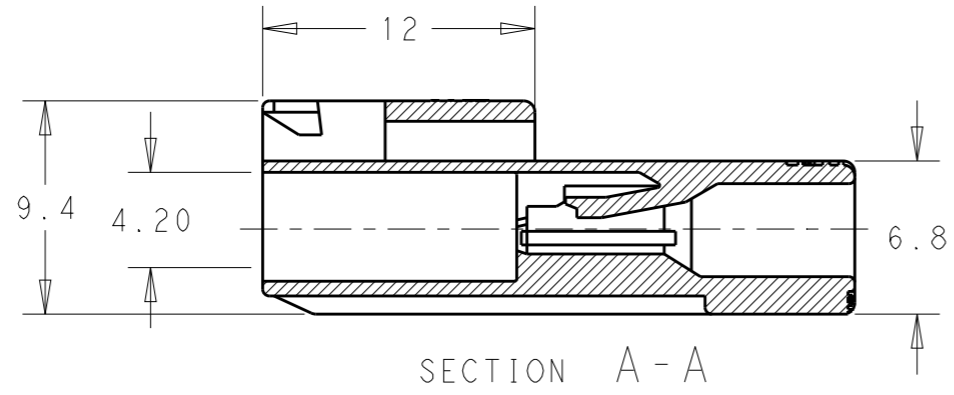
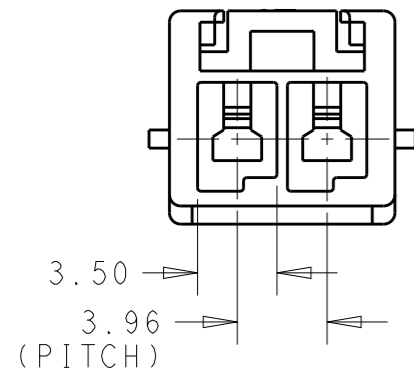

2	NATURAL	5-179463-1
2	BLACK	179463-9
2	BLUE	179463-6
2	GREEN	179463-5
2	YELLOW	179463-4
2	RED	179463-2
2	NATURAL	179463-1
POS	COLOR	PART NUMBER

5 TABLE 1

TRADE MARK	MANUFACTURING PLACE
- AMP OR AMP	JAPAN
-+AMP OR AMP	CHINA (PRC)
+ AMP OR AMP	KOREA

THIS DRAWING IS A CONTROLLED DOCUMENT.

DWN M. SUZUKI 23MAR1994	 TE Connectivity						
CHK M. SHINDO 25MAR1994							
APVD Y. KASHIWA 25MAR1994							
PRODUCT SPEC 108-5410							
MATERIAL 6/6 NYLON (UL 94V-0)	FINISH -	APPLICATION SPEC 114-5175	WEIGHT -	NAME AMP POWER DBL LOCK CONN 3.96mm PITCH (SGL ROW) 2 Pos CAP HOUSING(F/H)			
CUSTOMER DRAWING				SIZE A3	CAGE CODE 00779	DRAWING NO C-179463	RESTRICTED TO
				SCALE 3:1	SHEET 1 OF 1	REV D4	