

PRODUCT SUMMARY

SKY82896/97: Three-Channel/Two-Channel Boost LED Driver with I²C Interface

Applications

- Smartphones
- Tablets
- Portable media players

Features

- Input voltage range: 2.5 V to 5.5 V
- Three channels with up to 9 LEDs in series (up to 27 LEDs)
 - 30 mA max LED current
 - $\pm 2\%$ current accuracy and $\pm 2\%$ matching
- Backlight power reduction:
 - Output efficiency up to 90%
 - Shutdown current: $< 1 \mu\text{A}$
- Ultra-high resolution dimming:
 - 10-bit dimming I²C /analog-PWM/direct-PWM
 - 100 Hz to 25 KHz APWM capability
 - 100 Hz to 50 kHz DPWM capability
- Comprehensive system protection:
 - Integrated and programmable over-voltage protection
 - Open/short LED protection, over-temperature and boost over-current protection
- Display system optimization:
 - Programmable fade-in/fade-out
 - Adjustable compensation to optimize image quality
 - PWM options do not require I²C control
 - Separate inputs for APWM and DPWM dimming mixing for up to 20-bit dimming resolution
- Adjustable current limit for smallest inductor
- Ultra-small, low-profile WLCSP (16-bump, 1.956 mm \times 1.906 mm) package (MSL1, 260 °C per JEDEC J-STD-020)



Skyworks Green™ products are compliant with all applicable legislation and are halogen-free. For additional information, refer to *Skyworks Definition of Green™*, document number SQ04-0074.

Description

The SKY82896 is a step-up, three-channel LED driver with an input voltage range of 2.5 V to 5.5 V. The SKY82897 is a two-channel version of the SKY82896. The wide input voltage and high-boost switching frequency allow for a small solution size. Advanced dimming features and minimal external components make this device suitable for LED backlight solutions in single-cell, Li-Ion battery-based applications.

An integrated boost converter provides a high-voltage output for driving up to 30 V. Three precision current sinks are programmable up to 30 mA per string. The 900 kHz switching frequency supports ultra-small, low-profile external components.

The SKY82896/97 supports three different types of dimming:

- Direct Pulse Width Modulation (DPWM) dimming receives the input PWM control signal from the PWM pin and generates the PWM output. Frequency and the ON duty are controlled by the input control signal.
- Analog Pulse Width Modulation (APWM) dimming receives the input PWM control signal from the PWM pin and converts the ON duty of the input signal to an LED current control signal.
- I²C dimming adjusts the LED current through the I²C interface.

The APWM dimming input frequency ranges from 100 Hz to 25 kHz, and the DPMW dimming input frequency ranges from 100 Hz to 50 kHz. The minimum output ON duty in DPWM dimming is limited by the minimum on-time (39 ns), which allows 10-bit resolution at 25 kHz DPWM frequency.

The device includes over-temperature protection, programmable over-voltage protection, boost over-current protection, and open/short LED protection.

The SKY82896/97 is available in a space-saving 1.956 mm \times 1.906 mm, 16-bump Wafer-Level Chip Scale (WLCSP) package.

A typical application circuit is shown in Figure 1.

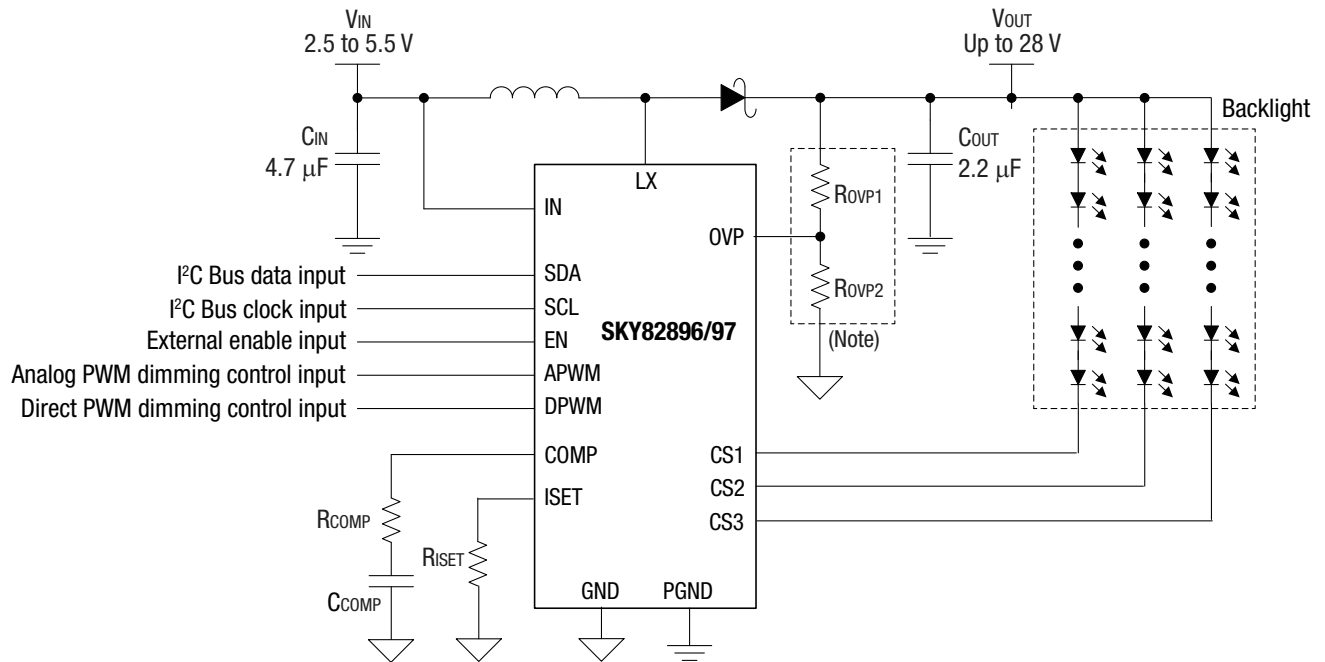

Note: External OVP resistors are optional.
 Connect the OVP pin to Vout when external OVP resistors are not used.

t0588

Figure 1. SKY82896/97 Typical Application Circuit

Ordering Information

Model Name	Manufacturing Part Number	Evaluation Board Part Number
SKY82896-11: Three-Channel Boost LED Driver with I ² C Interface	SKY82896-11-001	SKY82896-11-EVB
SKY82896-12: Three-Channel Boost LED Driver for PWM Only Control	SKY82896-12-001	SKY82896-12-EVB
SKY82897-11: Two-Channel Boost LED Driver with I ² C Interface	SKY82897-11-001	SKY82897-11-EVB
SKY82897-12: Two-Channel Boost LED Driver for PWM Only Control	SKY82897-12-001	SKY82897-12-EVB

Copyright © 2015 Skyworks Solutions, Inc. All Rights Reserved.

Information in this document is provided in connection with Skyworks Solutions, Inc. ("Skyworks") products or services. These materials, including the information contained herein, are provided by Skyworks as a service to its customers and may be used for informational purposes only by the customer. Skyworks assumes no responsibility for errors or omissions in these materials or the information contained herein. Skyworks may change its documentation, products, services, specifications or product descriptions at any time, without notice. Skyworks makes no commitment to update the materials or information and shall have no responsibility whatsoever for conflicts, incompatibilities, or other difficulties arising from any future changes.

No license, whether express, implied, by estoppel or otherwise, is granted to any intellectual property rights by this document. Skyworks assumes no liability for any materials, products or information provided hereunder, including the sale, distribution, reproduction or use of Skyworks products, information or materials, except as may be provided in Skyworks Terms and Conditions of Sale.

THE MATERIALS, PRODUCTS AND INFORMATION ARE PROVIDED "AS IS" WITHOUT WARRANTY OF ANY KIND, WHETHER EXPRESS, IMPLIED, STATUTORY, OR OTHERWISE, INCLUDING FITNESS FOR A PARTICULAR PURPOSE OR USE, MERCHANTABILITY, PERFORMANCE, QUALITY OR NON-INFRINGEMENT OF ANY INTELLECTUAL PROPERTY RIGHT; ALL SUCH WARRANTIES ARE HEREBY EXPRESSLY DISCLAIMED. SKYWORKS DOES NOT WARRANT THE ACCURACY OR COMPLETENESS OF THE INFORMATION, TEXT, GRAPHICS OR OTHER ITEMS CONTAINED WITHIN THESE MATERIALS. SKYWORKS SHALL NOT BE LIABLE FOR ANY DAMAGES, INCLUDING BUT NOT LIMITED TO ANY SPECIAL, INDIRECT, INCIDENTAL, STATUTORY, OR CONSEQUENTIAL DAMAGES, INCLUDING WITHOUT LIMITATION, LOST REVENUES OR LOST PROFITS THAT MAY RESULT FROM THE USE OF THE MATERIALS OR INFORMATION, WHETHER OR NOT THE RECIPIENT OF MATERIALS HAS BEEN ADVISED OF THE POSSIBILITY OF SUCH DAMAGE.

Skyworks products are not intended for use in medical, lifesaving or life-sustaining applications, or other equipment in which the failure of the Skyworks products could lead to personal injury, death, physical or environmental damage. Skyworks customers using or selling Skyworks products for use in such applications do so at their own risk and agree to fully indemnify Skyworks for any damages resulting from such improper use or sale.

Customers are responsible for their products and applications using Skyworks products, which may deviate from published specifications as a result of design defects, errors, or operation of products outside of published parameters or design specifications. Customers should include design and operating safeguards to minimize these and other risks. Skyworks assumes no liability for applications assistance, customer product design, or damage to any equipment resulting from the use of Skyworks products outside of stated published specifications or parameters.

Skyworks and the Skyworks symbol are trademarks or registered trademarks of Skyworks Solutions, Inc., in the United States and other countries. Third-party brands and names are for identification purposes only, and are the property of their respective owners. Additional information, including relevant terms and conditions, posted at www.skyworksinc.com, are incorporated by reference.