

4-24 X .5 CROSS OVAL HEAD FORMING SCREW X 4

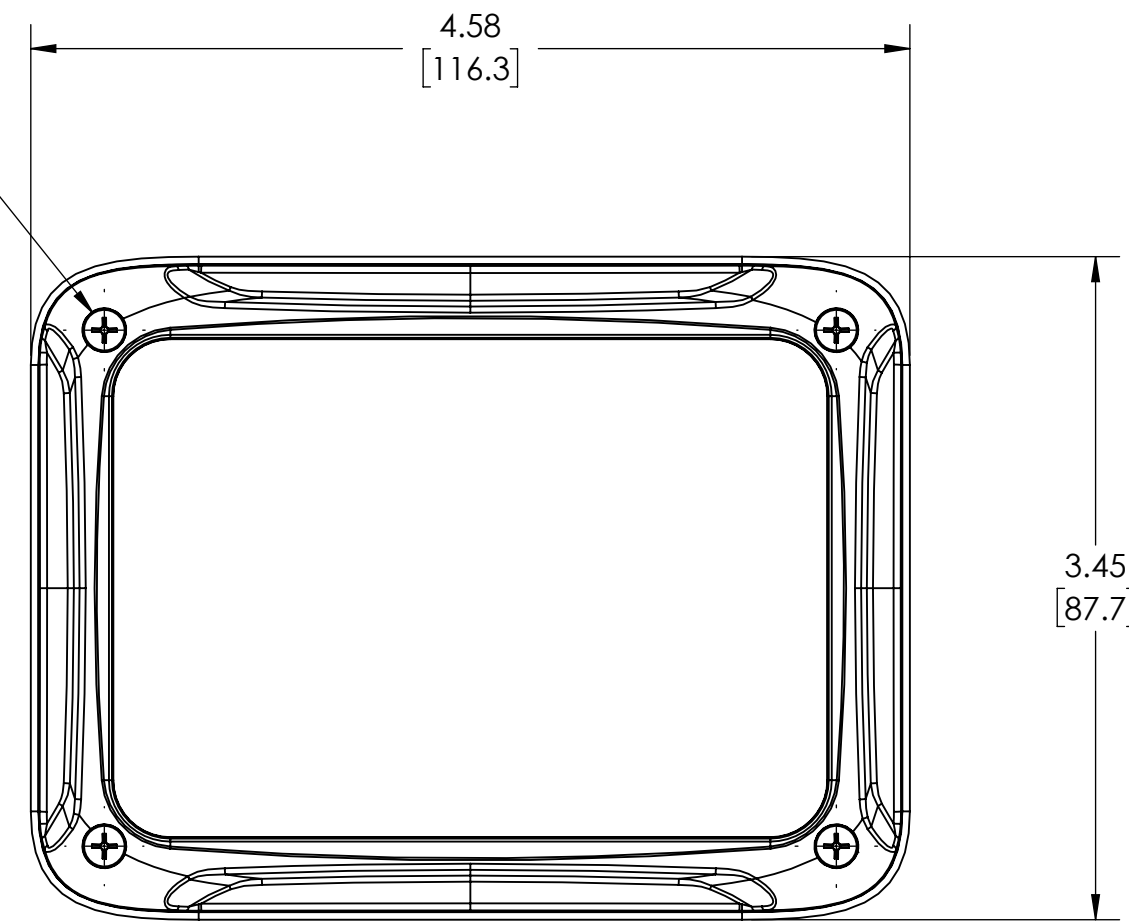

INSIDE VIEW OF BODY
COVER NOT SHOWN

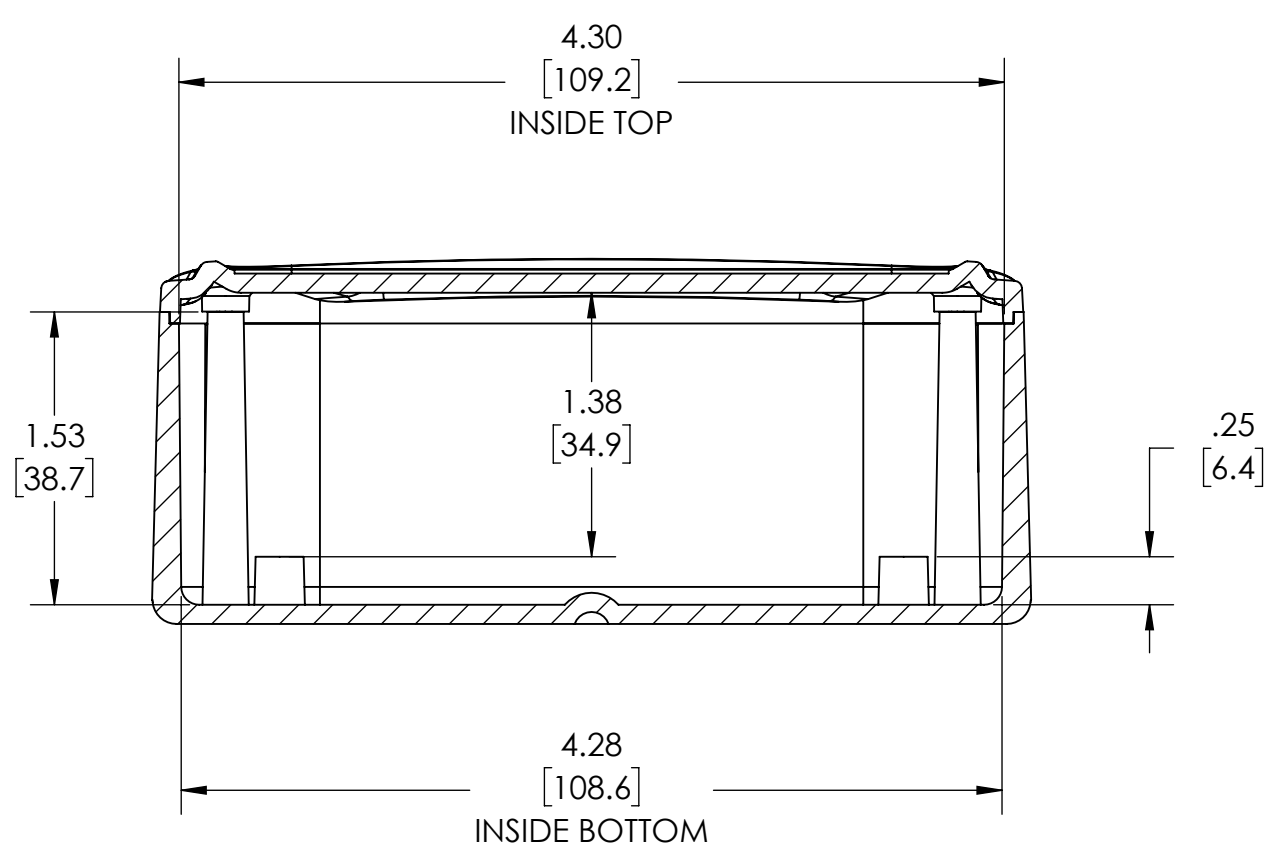
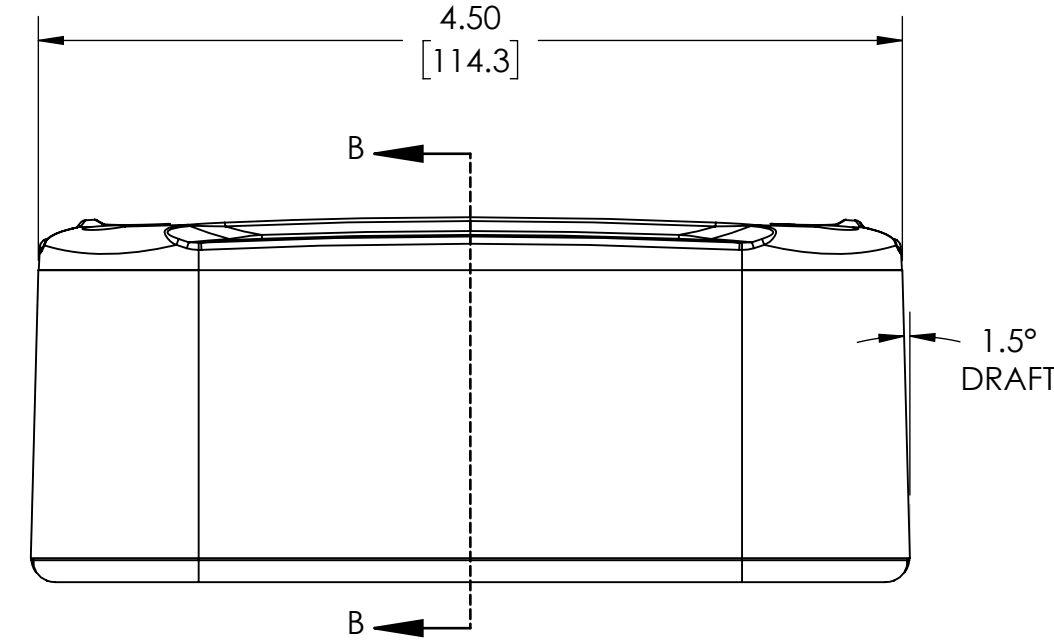
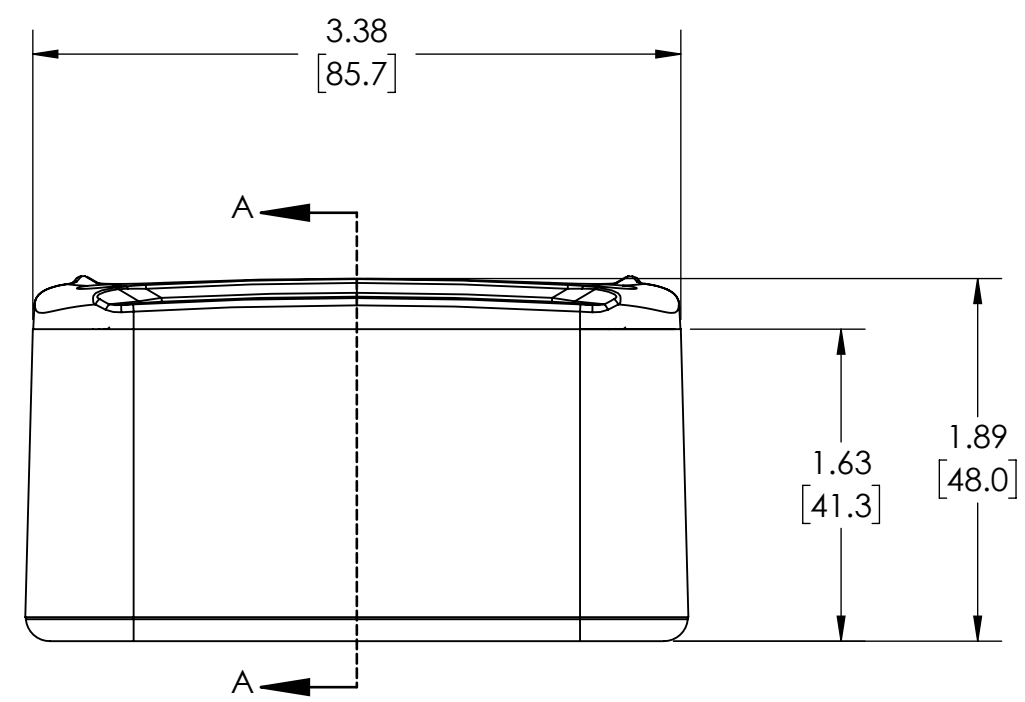

SECTION A-A

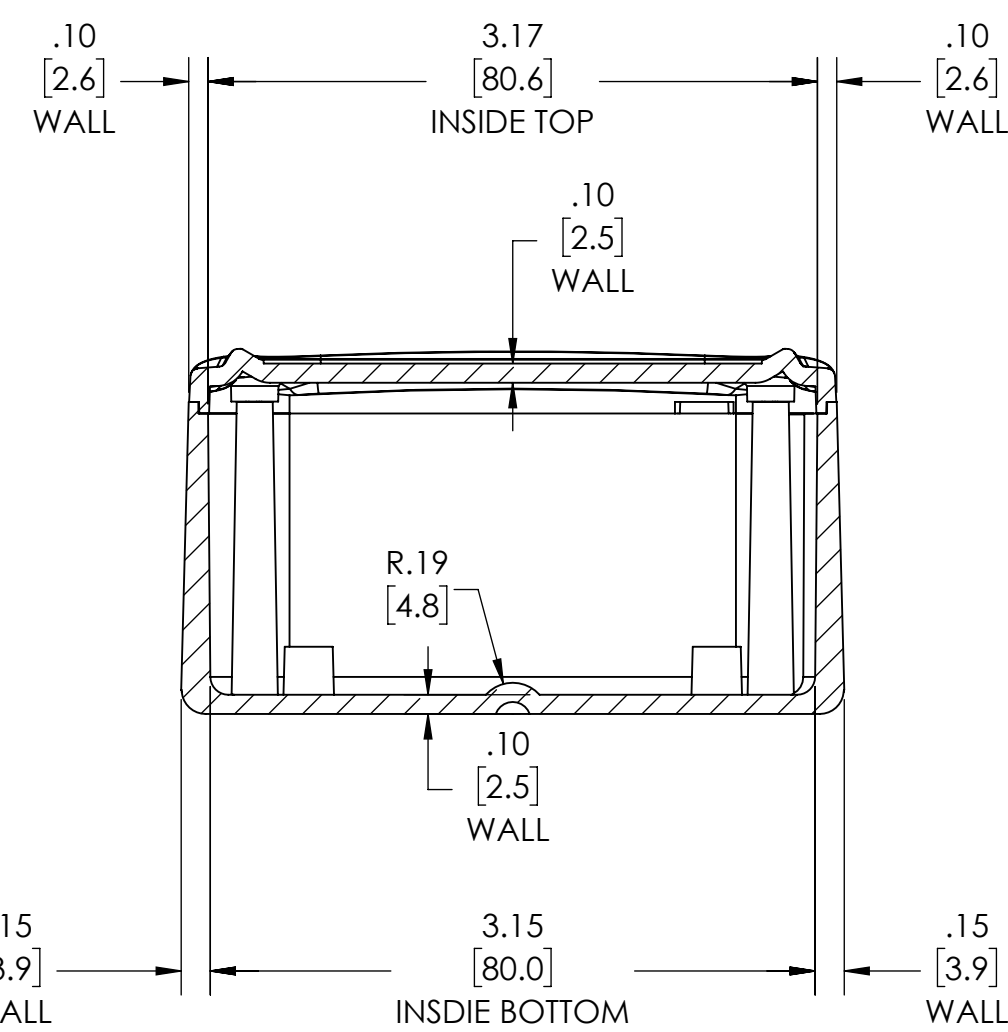

SECTION B-B

NOTES:

1. MATERIAL:
BODY- BLACK ABS POLYAC PA-765
COVER- BLACK ABS POLYAC PA-765
TEXTURED/FLUSH OR RECESSED SMOOTH
2. UL94 VO(1.5mm) AND 5VA (3mm) FLAMMABILITY RATING.
3. COVER IS REMOVABLE
4. DIMENSIONS ARE INCH [MM]

DRAWING FOR REFERENCE

WE RESERVE THE RIGHT TO MAKE CHANGES TO OUR STANDARD PRODUCTS. PLEASE CONSULT WITH BUD INDUSTRIES PRIOR TO USING THIS DRAWING FOR DESIGN PURPOSE.

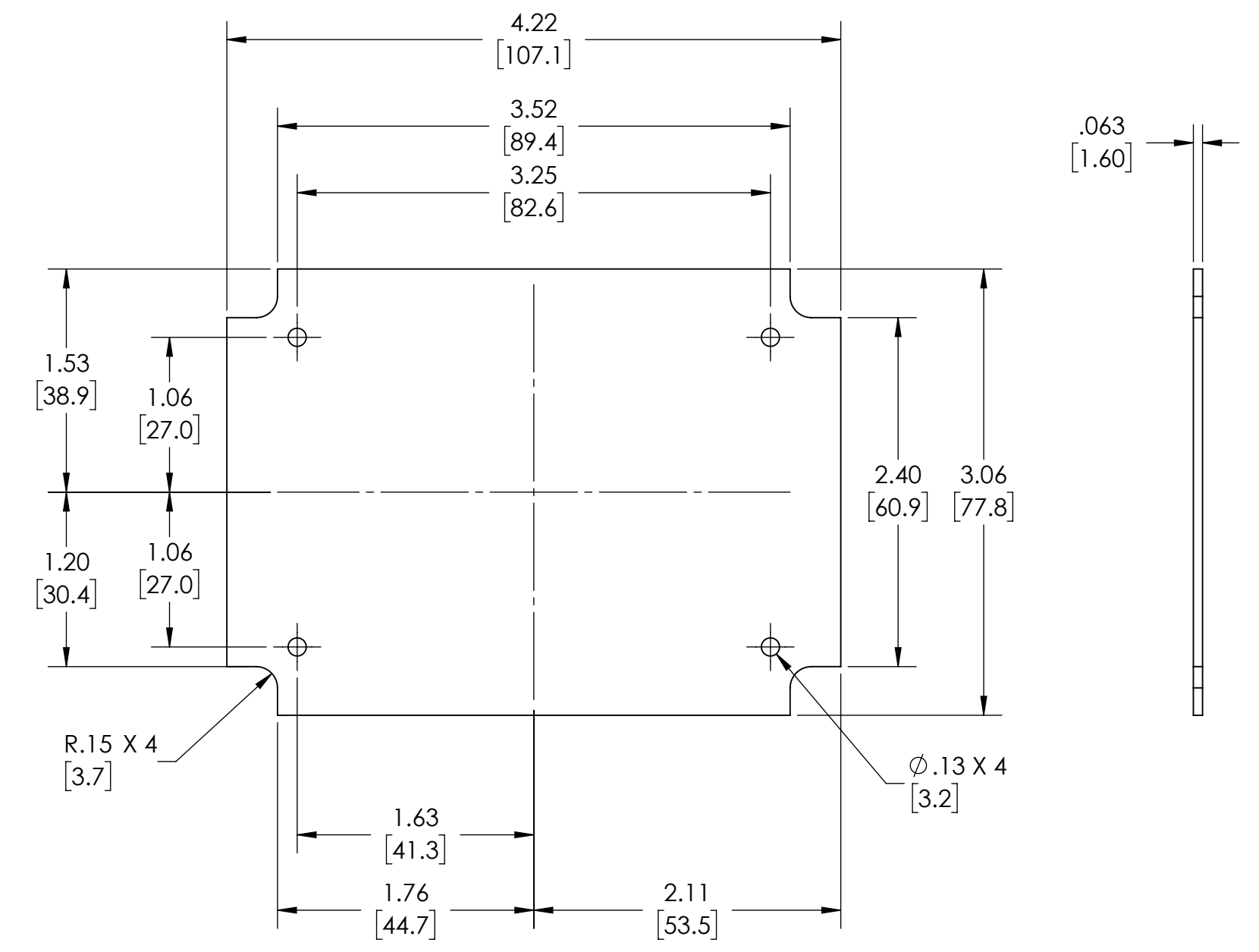

SUGGESTED PCB LAYOUT

