



Numonyx™ StrataFlash® Embedded Memory (J3-65nm)

256-Mbit

Datasheet

Product Features

- Architecture
 - Multi-Level Cell Technology: Highest Density at Lowest Cost
 - 256 symmetrically-sized blocks of 128 Kbytes
- Performance
 - 95 ns initial access time for Easy BGA
 - 105 ns initial access time for TSOP
 - 25 ns 16-word Asynchronous page-mode reads
 - 512-Word Buffer Programming at 1.46MByte/s (Typ)
- Voltage and Power
 - V_{CC} (Core) = 2.7 V to 3.6 V
 - V_{CCQ} (I/O) = 2.7 V to 3.6 V
 - Standby Current: 65 μ A (Typ)
 - Erase & Program Current: 35 mA (Typ)
 - Page Read: 12 mA (Typ)
- Quality and Reliability
 - Operating temperature: -40 °C to +85 °C
 - 100K Minimum erase cycles per block
 - 65 nm Numonyx™ ETOX™ X Process technology
- Security
 - Enhanced security options for code protection
 - Absolute protection with $V_{PEN} = GND$
 - Individual block locking
 - Block erase/program lockout during power transition
 - Password Access feature
 - One-Time Programmable Register: 64 OTP bits, programmed with unique information by Numonyx
 - 64 OTP bits, available for customer programming
- Software
 - 20 μ s (Typ) program suspend
 - 20 μ s (Typ) erase suspend
 - Numonyx™ Flash Data Integrator (FDI)
 - Common Flash Interface (CFI) Compatible
- Packaging
 - 56-Lead TSOP
 - 64-Ball Easy BGA package

INFORMATION IN THIS DOCUMENT IS PROVIDED IN CONNECTION WITH NUMONYX™ PRODUCTS. NO LICENSE, EXPRESS OR IMPLIED, BY ESTOPPEL OR OTHERWISE, TO ANY INTELLECTUAL PROPERTY RIGHTS IS GRANTED BY THIS DOCUMENT. EXCEPT AS PROVIDED IN NUMONYX'S TERMS AND CONDITIONS OF SALE FOR SUCH PRODUCTS, NUMONYX ASSUMES NO LIABILITY WHATSOEVER, AND NUMONYX DISCLAIMS ANY EXPRESS OR IMPLIED WARRANTY, RELATING TO SALE AND/OR USE OF NUMONYX PRODUCTS INCLUDING LIABILITY OR WARRANTIES RELATING TO FITNESS FOR A PARTICULAR PURPOSE, MERCHANTABILITY, OR INFRINGEMENT OF ANY PATENT, COPYRIGHT OR OTHER INTELLECTUAL PROPERTY RIGHT. Numonyx products are not intended for use in medical, life saving, life sustaining, critical control or safety systems, or in nuclear facility applications.

Numonyx B.V. may make changes to specifications and product descriptions at any time, without notice.

Numonyx B.V. may have patents or pending patent applications, trademarks, copyrights, or other intellectual property rights that relate to the presented subject matter. The furnishing of documents and other materials and information does not provide any license, express or implied, by estoppel or otherwise, to any such patents, trademarks, copyrights, or other intellectual property rights.

Designers must not rely on the absence or characteristics of any features or instructions marked "reserved" or "undefined." Numonyx reserves these for future definition and shall have no responsibility whatsoever for conflicts or incompatibilities arising from future changes to them.

Contact your local Numonyx sales office or your distributor to obtain the latest specifications and before placing your product order.

Copies of documents which have an order number and are referenced in this document, or other Numonyx literature may be obtained by visiting the Numonyx website at <http://www.numonyx.com>.

Numonyx, the Numonyx logo, and StrataFlash are trademarks or registered trademarks of Numonyx B.V. or its subsidiaries in other countries.

*Other names and brands may be claimed as the property of others.

Copyright © 2008, Numonyx B.V., All Rights Reserved.

Contents

1.0	Functional Overview	5
1.1	Document purpose	5
1.2	Product overview.....	5
1.3	Configuration & Memory Map	7
1.4	Device ID	8
2.0	Package Information	9
2.1	56-Lead TSOP Package, 256-Mbit	9
2.2	Easy BGA Package, 256-Mbit	11
3.0	Ballout	12
3.1	Easy BGA Ballout, 256-Mbit	12
3.2	56-Lead TSOP Package Pinout, 256-Mbit	13
4.0	Signal Descriptions	14
5.0	Bus Interface	15
5.1	Reads	16
5.2	Writes.....	16
5.3	Output Disable.....	16
5.4	Standby	16
5.5	Reset.....	17
6.0	Command Set	18
6.1	Device Command Codes	18
6.2	Device Command Bus Cycle.....	19
7.0	Read operation	21
7.1	Read Array	21
7.2	Asynchronous Page Mode Read	21
7.3	Read Status Register	22
7.4	Read Device Information	22
7.5	CFI Query	22
8.0	Program operation	24
8.1	Single-Word/Byte Programming	24
8.2	Buffered Programming	24
8.3	Suspend/Resume	25
9.0	Erase Operation	26
9.1	Block Erase	26
9.2	Suspend/Resume	26
10.0	Security	28
10.1	Normal Block Locking.....	28
10.2	Configurable Block Locking	28
10.3	VPEN Protection	29
10.4	Password Access	29
11.0	Registers	30
11.1	Status Register	30
11.2	Status Signal	31
11.3	OTP Protection Register.....	32
12.0	Power and Reset Specifications	35
12.1	Power-Up and Power-Down.....	35

12.2	Reset Specifications	36
12.3	Power Supply Decoupling	37
13.0	Maximum Ratings and Operating Conditions	38
13.1	Absolute Maximum Ratings	38
13.2	Operating Conditions.....	38
14.0	Electrical characteristics	39
14.1	DC Current Specifications	39
14.2	DC Voltage Specifications.....	40
14.3	Capacitance	40
15.0	AC characteristics	41
15.1	AC Test Conditions.....	41
15.2	AC Read Specifications	43
15.3	AC Write Specification	46
16.0	Program and erase characteristics	48
16.1	Program & Erase Specifications.....	48
17.0	Ordering Information	49
A	Reference Information	50
A.1	Common Flash Interface.....	50
A.2	Query Structure Output	50
A.3	Flow Charts.....	57
B	Terms, definitions, and acronyms	62
B.1	Nomenclature.....	62
B.2	Acronyms	62
B.3	Conventions.....	63
C	Revision History.....	64

1.0 Functional Overview

The Numonyx™ StrataFlash® Embedded Memory (J3-65nm) provides improved mainstream performance with enhanced security features, taking advantage of the high quality and reliability of the NOR-based Numonyx 65 nm ETOX™ X process technology. Offered in 32-Mbit up through 256-Mbit densities, the Numonyx™ Embedded Memory (J3-65nm) device brings reliable, low-voltage capability (3 V read, program, and erase) with high speed, low-power operation. The Numonyx™ StrataFlash® Embedded Memory (J3-65nm) device is ideal for code and data applications where high density and low cost are required, such as in networking, telecommunications, digital set top boxes, audio recording, and digital imaging. Numonyx Flash Memory components also deliver a new generation of forward-compatible software support. By using the Common Flash Interface (CFI) and Scalable Command Set (SCS), customers can take advantage of density upgrades and optimized write capabilities of future Numonyx Flash Memory devices.

1.1 Document purpose

This document contains information pertaining to the Numonyx™ StrataFlash® Embedded Memory (J3-65nm) device features, operation, and specifications.

The Numonyx™ Embedded Memory (J3-65nm) device is offered in Single Bit Cell technology for 32-, 64-, 128-Mbit densities. The Numonyx™ StrataFlash® Embedded Memory (J3-65nm) device is offered in Multi-Level Cell technology for 256-Mbit density. This document just covers 256-Mbit die information.

Unless otherwise indicated throughout the rest of this document, Numonyx™ StrataFlash® Embedded Memory (J3-65nm) is referred to as J3-65nm.

1.2 Product overview

The 256-Mbit J3-65nm is organized as 256 individual 128Kbyte symmetrical blocks.

A 128-bit Protection Register has multiple uses, including unique flash device identification.

The J3-65nm device includes new security features that were not available on the (previous) 0.25µm, 0.18µm, and 0.13µm versions of the J3 family. The new security features can be implemented to protect critical code and data from unwanted modification (program or erase). Usage can be defined to fit the specific needs of each customer.

The J3-65nm optimized architecture and interface dramatically increases read performance by supporting page-mode reads. This read mode is ideal for non-clock memory systems.

The J3-65nm Common Flash Interface (CFI) permits software algorithms to be used for entire families of devices. This allows device-independent, JEDEC ID-independent, and forward- and backward-compatible software support for the specified flash device families. Flash vendors can standardize their existing interfaces for long-term compatibility.

The Scalable Command Set (SCS) allows a single, simple software driver in all host systems to work with all SCS-compliant flash memory devices, independent of system-level packaging (e.g., memory card, SIMM, or direct-to-board placement). Additionally, SCS provides the highest system/device data transfer rates and minimizes device and system-level implementation costs.

A Command User Interface (CUI) serves as the interface between the system processor and internal operation of the device. A valid command sequence written to the CUI initiates device automation. An internal Write State Machine (WSM) automatically executes the algorithms and timings necessary for block erase, program, and lock-bit configuration operations.

A block erase operation erases one of the device's 128-Kbyte blocks typically within one second, independent of other blocks. Each block can be independently erased 100,000 times. Block erase suspend mode allows system software to suspend block erase to read or program data from any other block. Similarly, program suspend allows system software to suspend programming (byte/word program and write-to-buffer operations) to read data or execute code from any other block that is not being suspended.

Each device incorporates a Write Buffer of 512 words to allow optimum programming performance. By using the Write Buffer data is programmed more efficiently in buffer increments.

Memory Blocks are selectively and individually lockable in-system. Individual block locking uses block lock-bits to lock and unlock blocks. Block lock-bits gate block erase and program operations. Lock-bit configuration operations set and clear lock-bits (using the Set Block Lock-Bit and Clear Block Lock-Bits commands).

The Status Register indicates when the WSM's block erase, program, or lock-bit configuration operation completes.

The STS (status) output gives an additional indicator of WSM activity by providing both a hardware signal of status (versus software polling) and status masking (interrupt masking for background block erase, for example). Status indication using STS minimizes both CPU overhead and system power consumption. When configured in level mode (default mode), it acts as a RY/BY# signal. When low, STS indicates that the WSM is performing a block erase, program, or lock-bit configuration. STS-high indicates that the WSM is ready for a new command, block erase is suspended (and programming is inactive), program is suspended, or the device is in reset/power-down mode. Additionally, the configuration command allows the STS signal to be configured to pulse on completion of programming and/or block erases.

Three CE signals are used to enable and disable the device. A unique CE logic design (see [Table 6, "Chip Enable Truth Table for 256-Mb" on page 15](#)) reduces decoder logic typically required for multi-chip designs. External logic is not required when designing a single chip, a dual chip, or a 4-chip miniature card or SIMM module.

The BYTE# signal allows either x8 or x16 read/writes to the device:

- BYTE#-low enables 8-bit mode; address A0 selects between the low byte and high byte.
- BYTE#-high enables 16-bit operation; address A1 becomes the lowest order address and address A0 is not used (don't care).

When the device is disabled (see [Table 6, "Chip Enable Truth Table for 256-Mb" on page 15](#)), with CEx at V_{IH} and RP# at V_{IH} , the standby mode is enabled. When RP# is at V_{IL} , a further power-down mode is enabled which minimizes power consumption and provides write protection during reset. A reset time (t_{PHQV}) is required from RP# going high until data outputs are valid. Likewise, the device has a wake time (t_{PHWL}) from RP#-high until writes to the CUI are recognized. With RP# at V_{IL} , the WSM is reset and the Status Register is cleared.

1.3 Configuration & Memory Map

The J3-65nm device features a symmetrically-blocked architecture. The flash device main array is divided as follows:

- 256-Mbit, organized into *two-hundred-fifty-six* 128-Kbyte blocks.

Figure 1: J3-65nm Memory Map

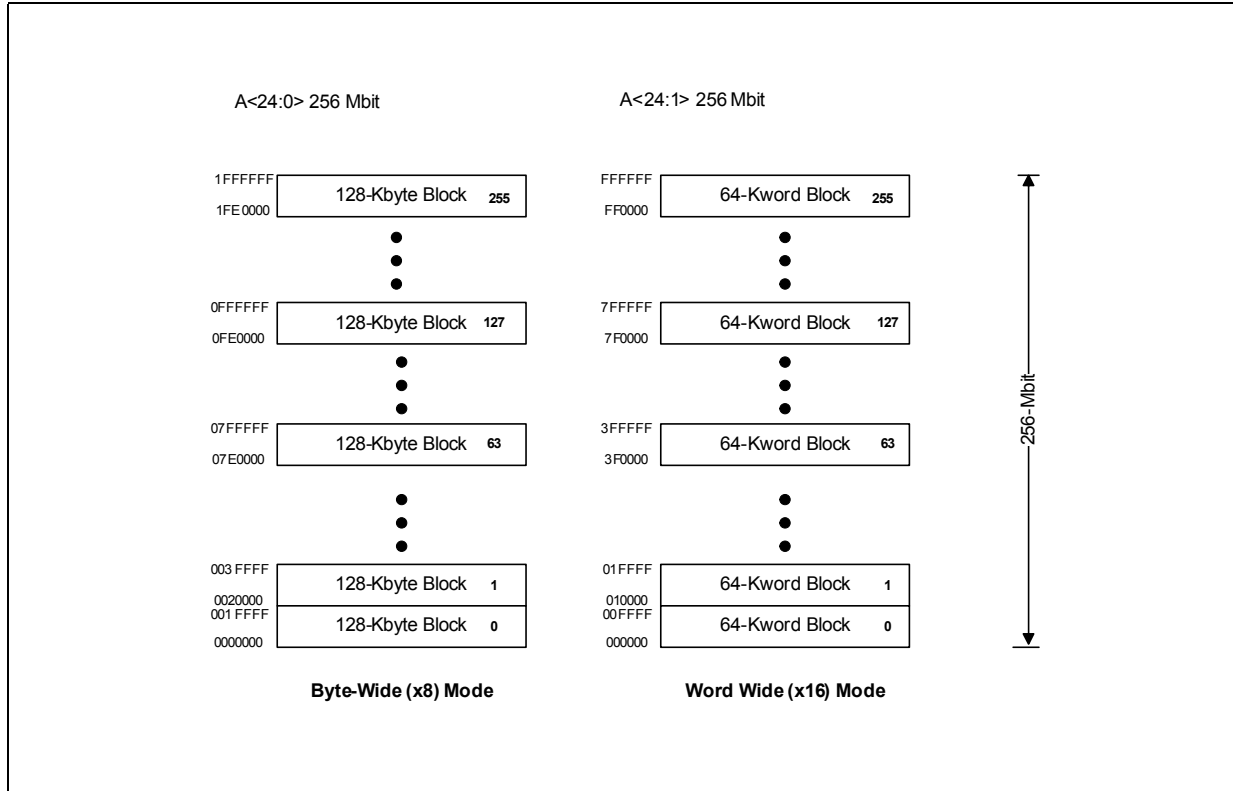

1.4 Device ID

Table 1: Device Identifier Codes

Code		Address	Data
Device Code	256-Mbit	00001h	001Dh

2.0 Package Information

2.1 56-Lead TSOP Package, 256-Mbit

Figure 2: 56-Lead TSOP Package Mechanical

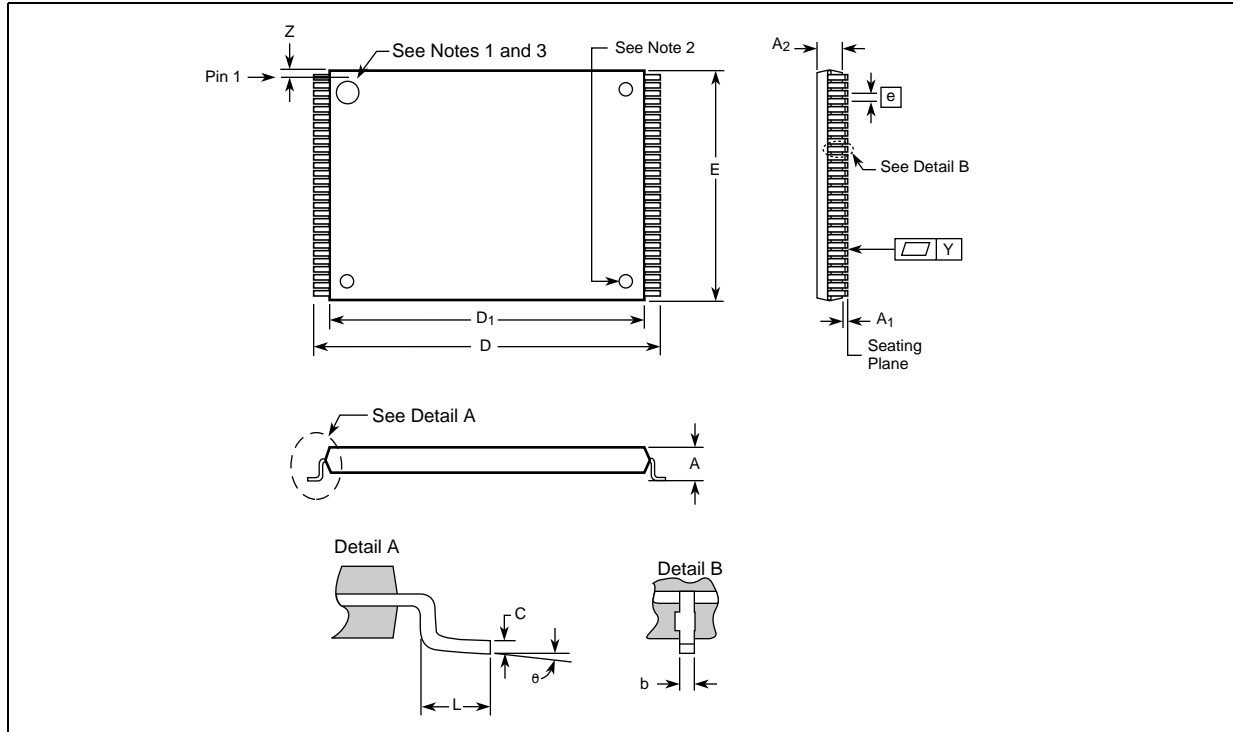

Notes:

1. One dimple on package denotes Pin 1.
2. If two dimples, then the larger dimple denotes Pin 1.
3. Pin 1 will always be in the upper left corner of the package, in reference to the product mark.

Table 2: 56-Lead TSOP Dimension Table

Parameter	Symbol	Millimeters			Inches		
		Min	Nom	Max	Min	Nom	Max
Package Height	A			1.200			0.047
Standoff	A ₁	0.050			0.002		
Package Body Thickness	A ₂	0.965	0.995	1.025	0.038	0.039	0.040
Lead Width	b	0.100	0.150	0.200	0.004	0.006	0.008
Lead Thickness	c	0.100	0.150	0.200	0.004	0.006	0.008
Package Body Length	D ₁	18.200	18.400	18.600	0.717	0.724	0.732
Package Body Width	E	13.800	14.000	14.200	0.543	0.551	0.559
Lead Pitch	e		0.500			0.0197	

Table 2: 56-Lead TSOP Dimension Table

Parameter	Symbol	Millimeters			Inches		
		Min	Nom	Max	Min	Nom	Max
Terminal Dimension	D	19.800	20.00	20.200	0.780	0.787	0.795
Lead Tip Length	L	0.500	0.600	0.700	0.020	0.024	0.028
Lead Count	N		56			56	
Lead Tip Angle	θ	0°	3°	5°	0°	3°	5°
Seating Plane Coplanarity	Y			0.100			0.004
Lead to Package Offset	Z	0.150	0.250	0.350	0.006	0.010	0.014

2.2 Easy BGA Package, 256-Mbit

Figure 3: Easy BGA Mechanical Specifications

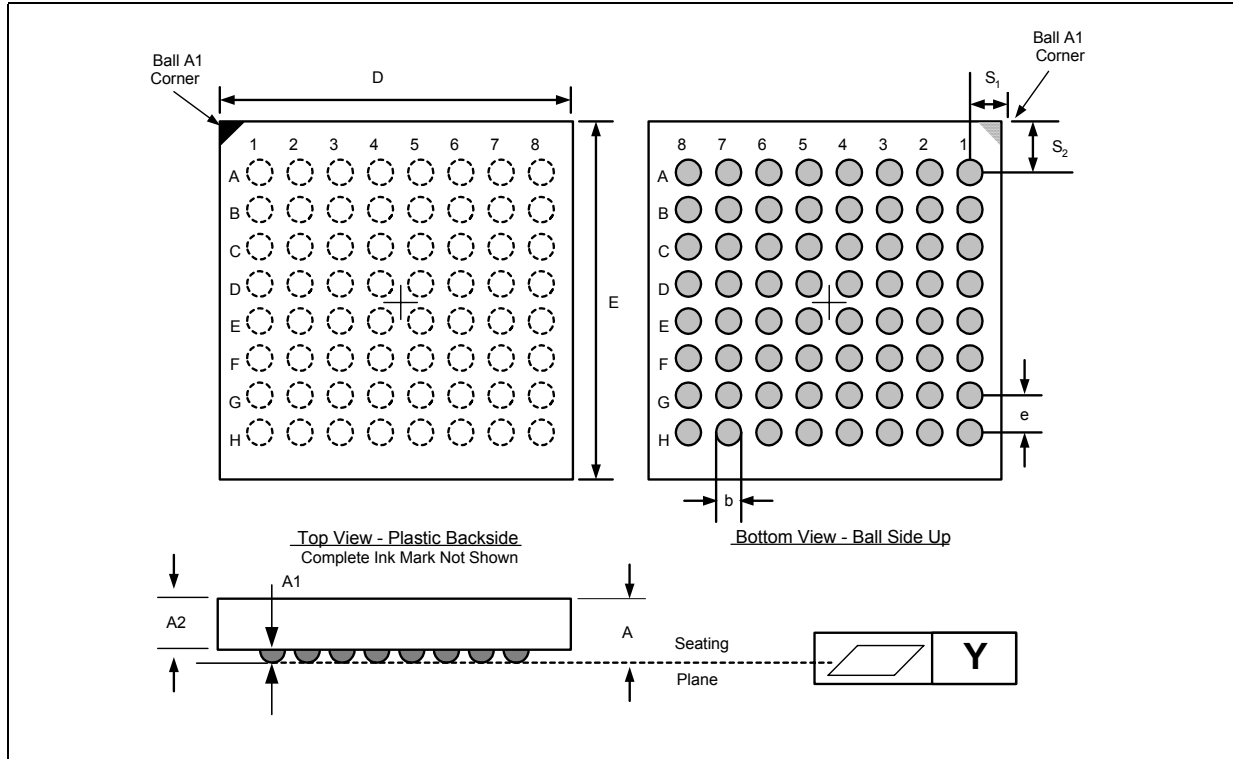

Table 3: Easy BGA Package Dimensions Table

Parameter	Symbol	Millimeters			Inches		
		Min	Nom	Max	Min	Nom	Max
Package Height (256 Mbit)	A			1.200			0.0472
Ball Height	A1	0.250			0.0098		
Package Body Thickness (256 Mbit)	A2		0.780			0.0307	
Ball (Lead) Width	b	0.330	0.430	0.530	0.0130	0.0169	0.0209
Package Body Width	D	9.900	10.000	10.100	0.3898	0.3937	0.3976
Package Body Length	E	12.900	13.000	13.100	0.5079	0.5118	0.5157
Pitch	e		1.000			0.0394	
Ball (Lead) Count	N		64			64	
Seating Plane Coplanarity	Y			0.100			0.0039
Corner to Ball A1 Distance Along D (256 Mb)	S1	1.400	1.500	1.600	0.0551	0.0591	0.0630
Corner to Ball A1 Distance Along E (256 Mb)	S2	2.900	3.000	3.100	0.1142	0.1181	0.1220

3.0 Ballout

J3-65nm is available in two package types. All densities of the J3-65nm devices are supported on both 64-ball Easy BGA and 56-lead Thin Small Outline Package (TSOP) packages. The figures below show the ballouts.

3.1 Easy BGA Ballout

Figure 4: Easy BGA Ballout

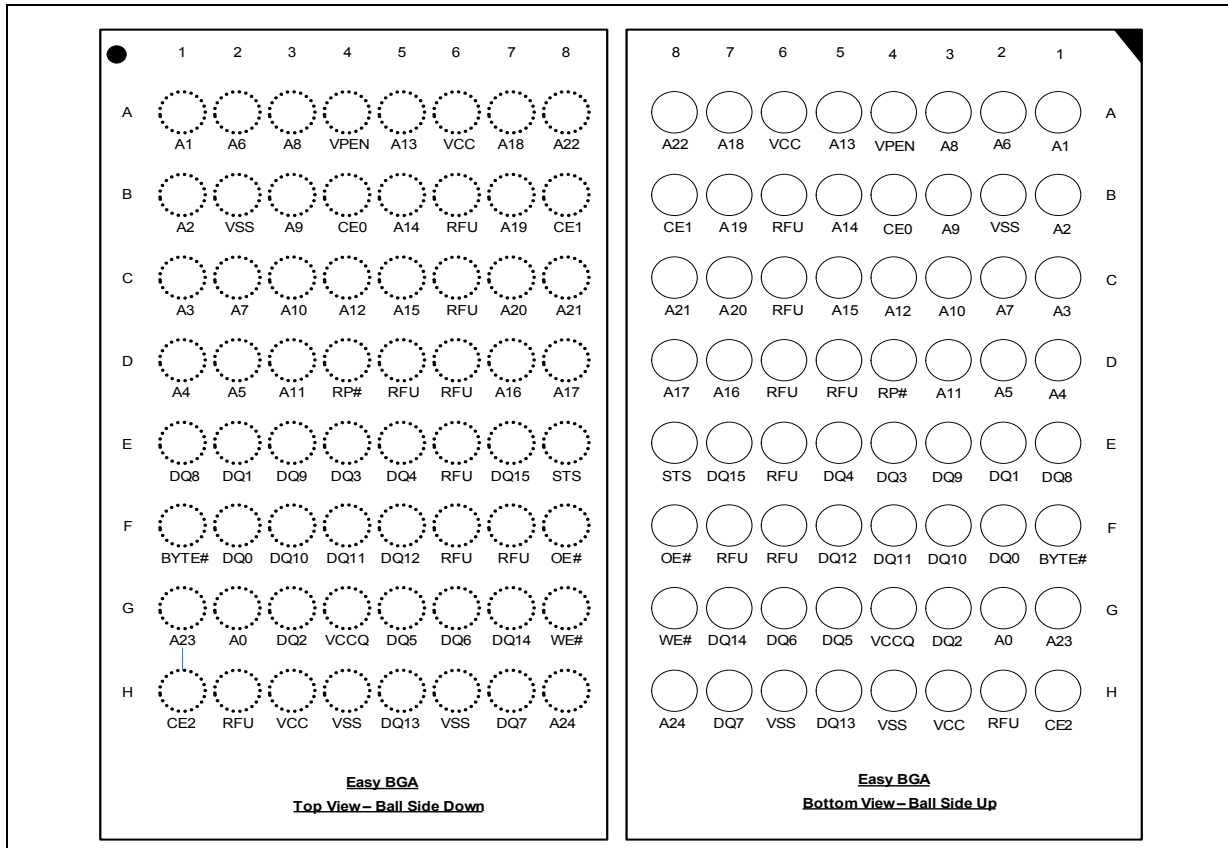

3.2 56-Lead TSOP Package Pinout, 256-Mbit

Figure 5: 56-Lead TSOP Package Pinout (256 Mbit)

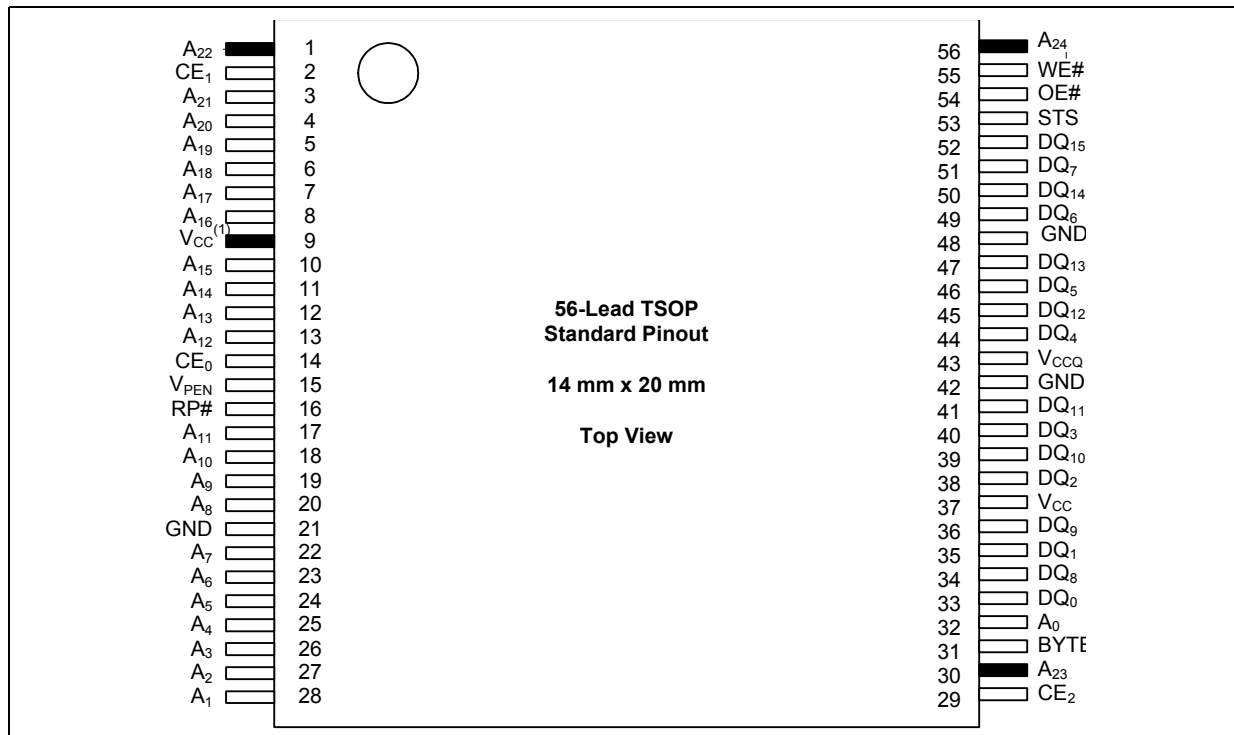

Notes:

1. No internal connection on Pin 9; it may be driven or floated. For legacy designs, pin can be tied to Vcc.

4.0 Signal Descriptions

Table 4 lists the active signals used on J3-65nm and provides a description of each.

Table 4: TSOP & Easy BGA Signal Descriptions

Symbol	Type	Name and Function
A0	Input	BYTE-SELECT ADDRESS: Selects between high and low byte when the device is in x8 mode. This address is latched during a x8 program cycle. Not used in x16 mode (i.e., the A0 input buffer is turned off when BYTE# is high).
A[MAX:1]	Input	ADDRESS INPUTS: Inputs for addresses during read and program operations. Addresses are internally latched during a program cycle: 256-Mbit — A[24:1]
DQ[7:0]	Input/ Output	LOW-BYTE DATA BUS: Inputs data during buffer writes and programming, and inputs commands during CUI writes. Outputs array, CFI, identifier, or status data in the appropriate read mode. Data is internally latched during write operations.
DQ[15:8]	Input/ Output	HIGH-BYTE DATA BUS: Inputs data during x16 buffer writes and programming operations. Outputs array, CFI, or identifier data in the appropriate read mode; not used for Status Register reads. Data is internally latched during write operations in x16 mode. DQ[15:8] float in x8 mode
CE[2:0]	Input	CHIP ENABLE: Activate the 256-Mbit devices' control logic, input buffers, decoders, and sense amplifiers. When the device is de-selected (see Table 6, "Chip Enable Truth Table for 256-Mb" on page 15), power reduces to standby levels. All timing specifications are the same for these three signals. Device selection occurs with the falling edge of CE0, CE1, or CE2 that enables the device. Device deselection occurs with the rising edge of CE0, CE1, or CE2 that disables the device (see Table 6, "Chip Enable Truth Table for 256-Mb" on page 15).
RP#	Input	RESET: RP#-low resets internal automation and puts the device in power-down mode. RP#-high enables normal operation. Exit from reset sets the device to read array mode. When driven low, RP# inhibits write operations which provides data protection during power transitions.
OE#	Input	OUTPUT ENABLE: Activates the device's outputs through the data buffers during a read cycle. OE# is active low.
WE#	Input	WRITE ENABLE: Controls writes to the CUI, the Write Buffer, and array blocks. WE# is active low. Addresses and data are latched on the rising edge of WE#.
STS	Open Drain Output	STATUS: Indicates the status of the internal state machine. When configured in level mode (default), it acts as a RY/BY# signal. When configured in one of its pulse modes, it can pulse to indicate program and/or erase completion. For alternate configurations of the Status signal, see the Configurations command and Section 11.2, "Status Signal" on page 31. STS is to be tied to VCCQ with a pull-up resistor.
BYTE#	Input	BYTE ENABLE: BYTE#-low places the device in x8 mode; data is input or output on DQ[7:0], while DQ[15:8] is placed in High-Z. Address A0 selects between the high and low byte. BYTE#-high places the device in x16 mode, and turns off the A0 input buffer. Address A1 becomes the lowest-order address bit.
VPEN	Input	ERASE / PROGRAM / BLOCK LOCK ENABLE: For erasing array blocks, programming data, or configuring lock-bits. With $V_{PEN} \leq V_{PENLK}$, memory contents cannot be altered.
VCC	Power	CORE Power Supply: Core (logic) source voltage. Writes to the flash array are inhibited when $V_{CC} \leq V_{LKO}$. Caution: Device operation at invalid Vcc voltages should not be attempted.
VCCQ	Power	I/O Power Supply: Power supply for Input/Output buffers. This ball can be tied directly to VCC.
GND/VSS	Supply	GROUND: Ground reference for device logic voltages. Connect to system ground.
NC	—	No Connect: Lead is not internally connected; it may be driven or floated.
RFU	—	Reserved for Future Use: Balls designated as RFU are reserved by Numonyx for future device functionality and enhancement.

5.0 Bus Interface

This section provides an overview of Bus operations. There are three operations flash memory: Read, Program (Write), and Erase.

CE[2:0]-enable, OE#-low, WE#-high and RP#-high enable device read operations. Addresses are always assumed to be valid. OE#-low activates the outputs and gates selected data onto the I/O bus. WE#-low enables device write operations. [Table 5](#) summarizes the necessary states of each control signal for different modes of operations.

Table 5: Bus Operations

Mode	RP#	CE _x ⁽¹⁾	OE# ⁽²⁾	WE# ⁽²⁾	DQ _{15:0} ⁽³⁾	STS (Default Mode)	V _{PEN}	Notes
Reads: Async., Status, Query and Identifier	V _{IH}	Enabled	V _{IL}	V _{IH}	D _{OUT}	High-Z	X	4,6
Output Disable	V _{IH}	V _{IH}	Enabled	V _{IH}	High-Z	High-Z	X	
Command Writes	V _{IH}	Enabled	V _{IH}	V _{IL}	D _{IN}	High Z	X	6,7
Array Writes ⁽⁸⁾	V _{IH}	Enabled	V _{IH}	V _{IL}	D _{IN}	V _{IL}	V _{PENH}	8,5
Standby	V _{IH}	Disabled	X	X	High Z	High Z	X	
Reset/Power-down	V _{IL}	X	X	X	High Z	High Z	X	

Notes:

- See [Table 6](#) for valid CE_x Configurations.
- OE# and WE# should never be asserted simultaneously. If done so, OE# overrides WE#.
- DQ refers to DQ[7:0] when BYTE# is low and DQ[15:0] if BYTE# is high.
- Refer to DC characteristics. When V_{PEN} ≤ V_{PENLK}, memory contents can be read but not altered.
- X should be V_{IL} or V_{IH} for the control pins and V_{PENLK} or V_{PENH} for V_{PEN}. For outputs, X should be V_{OL} or V_{OH}.
- In default mode, STS is V_{OL} when the WSM is executing internal block erase, program, or a lock-bit configuration algorithm. It is V_{OH} (pulled up by an external pull up resistance ≈10k) when the WSM is not busy, in block erase suspend mode (with programming inactive), program suspend mode, or reset power-down mode.
- See [Table 7](#) for valid D_{IN} (user commands) during a Write operation
- Array writes are either program or erase operations.

CE0, CE1 and CE2 control device activation. With the proper input (see [Figure 6, "Chip Enable Truth Table for 256-Mb"](#)) the device gets selected, which in turn activates its internal circuits. WE# and OE# determine the direction of the data buffers (input or output).

Table 6: Chip Enable Truth Table for 256-Mb

CE2	CE1	CE0	DEVICE
V _{IL}	V _{IL}	V _{IL}	Enabled
V _{IL}	V _{IL}	V _{IH}	Disabled
V _{IL}	V _{IH}	V _{IL}	Disabled
V _{IL}	V _{IH}	V _{IH}	Disabled
V _{IH}	V _{IL}	V _{IL}	Enabled
V _{IH}	V _{IL}	V _{IH}	Enabled
V _{IH}	V _{IH}	V _{IL}	Enabled
V _{IH}	V _{IH}	V _{IH}	Disabled

Note: For single-chip applications, CE2 and CE1 can be connected to GND.

5.1 Reads

Reading from flash memory outputs stored information to the processor or chipset, and does not change any contents. Reading can be performed an unlimited number of times. Besides array data, other types of data such as device information or device status are available from the flash.

To perform a bus read operation, CEx (refer to [Table 6 on page 15](#)) and OE# must be asserted. CEx is the device-select control; when active, it enables the flash memory device. OE# is the data-output control; when active, the addressed flash memory data is driven onto the I/O bus. For all read states, WE# and RP# must be de-asserted. See [Section 7.0, "Read operation" on page 21](#).

5.2 Writes

Writing or Programming to the device is where the host writes information or data into the flash device for non-volatile storage. When the flash device is programmed, 'ones' are changed to 'zeros'. 'Zeros' cannot be programmed back to 'ones'. To do so, an erase operation must be performed. Writing commands to the Command User Interface (CUI) enables various modes of operation, including the following:

- Reading of array data
- Common Flash Interface (CFI) data
- Identifier codes, inspection, and clearing of the Status Register
- Block Erasure, Program, and Lock-bit Configuration (when $V_{PEN} = V_{PENH}$)

Erasing is performed on a block basis – all flash cells within a block are erased together. Any information or data previously stored in the block will be lost. Erasing is typically done prior to programming. The Block Erase command requires appropriate command data and an address within the block to be erased. The Byte/Word Program command requires the command and address of the location to be written. Set Block Lock-Bit commands require the command and block within the device to be locked. The Clear Block Lock-Bits command requires the command and address within the device to be cleared.

The CUI does not occupy an addressable memory location. It is written when the device is enabled and WE# is active. The address and data needed to execute a command are latched on the rising edge of WE# or the first edge of CE0, CE1, or CE2 that disables the device (see [Table 6 on page 15](#)). Standard microprocessor write timings are used.

5.3 Output Disable

With CEx asserted, and OE# at a logic-high level (V_{IH}), the device outputs are disabled. Output signals D[15:0] are placed in a high-impedance state.

5.4 Standby

CE0, CE1, and CE2 can disable the device (see [Table 6 on page 15](#)) and place it in standby mode. This manipulation of CEx substantially reduces device power consumption. D[15:0] outputs are placed in a high-impedance state independent of OE#. If deselected during block erase, program, or lock-bit configuration, the WSM continues functioning, and consuming active power until the operation completes.

5.5 Reset

RP# at V_{IL} initiates the reset/power-down mode.

In read modes, RP#-low deselects the memory, places output drivers in a high-impedance state, and turns off numerous internal circuits. RP# must be held low for a minimum of t_{PLPH} . Time t_{PHQV} is required after return from reset mode until initial memory access outputs are valid. After this wake-up interval, normal operation is restored. The CUI is reset to read array mode and Status Register is set to 0080h.

During Block Erase, Program, or Lock-Bit Configuration modes, RP#-low will abort the operation. In default mode, STS transitions low and remains low for a maximum time of $t_{PLPH} + t_{PHRH}$ until the reset operation is complete. Memory contents being altered are no longer valid; the data may be partially corrupted after a program or partially altered after an erase or lock-bit configuration. Time t_{PHWL} is required after RP# goes to logic-high (V_{IH}) before another command can be written.

As with any automated device, it is important to assert RP# during system reset. When the system comes out of reset, it expects to read from the flash memory. Automated flash memories provide status information when accessed during Block Erase, Program, or Lock-Bit Configuration modes. If a CPU reset occurs with no flash memory reset, proper initialization may not occur because the flash memory may be providing status information instead of array data. Numonyx Flash memories allow proper initialization following a system reset through the use of the RP# input. In this application, RP# is controlled by the same RESET# signal that resets the system CPU.

6.0 Command Set

6.1 Device Command Codes

The system Central Processing Unit provides control of all in-system read, write, and erase operations of the device via the system bus. The on-chip WSM manages all block-erase and program algorithms.

Device commands are written to the CUI to control all flash memory device operations. The CUI does not occupy an addressable memory location; it is the mechanism through which the flash device is controlled. [Table 7](#) shows valid device command codes and descriptions.

Table 7: Command Codes and Definitions (Sheet 1 of 2)

Mode	Code	Device Mode	Description
Read	0xFF	Read Array	Places the device in Read Array mode. Array data is output on DQ[15:0].
	0x70	Read Status Register	Places the device in Read Status Register mode. The device enters this mode after a program or erase command is issued. SR data is output on DQ[7:0].
	0x90	Read Device ID or Configuration Register	Places device in Read Device Identifier mode. Subsequent reads output manufacturer/device codes, Configuration Register data, Block Lock status, or OTP register data on DQ[15:0].
	0x98	Read Query	Places the device in Read Query mode. Subsequent reads output Common Flash Interface information on DQ[7:0].
	0x50	Clear Status Register	The WSM can only set SR error bits. The Clear Status Register command is used to clear the SR error bits.
Program	0x40	Word/Byte Program Setup	First cycle of a 2-cycle programming command. prepares the CUI for a write operation. On the next write cycle, the address and data are latched and the WSM executes the programming algorithm at the addressed location. During program operations, the device responds only to Read Status Register and Program Suspend commands. CE _x or OE# must be toggled to update the Status Register in asynchronous read. CE _x must be toggled to update the SR Data for synchronous Non-array reads. The Read Array command must be issued to read array data after programming has finished.
	0xE8	Buffered Program	This command loads a variable number of words up to the buffer size of 512 words onto the program buffer in x16 mode. ⁽¹⁾
	0xD0	Program Confirm	The confirm command is Issued after the data streaming for writing into the buffer is done. This instructs the WSM to perform the Buffered Program algorithm, writing the data from the buffer to the flash memory array.
Erase	0x20	Block Erase Setup	First cycle of a 2-cycle command; prepares the CUI for a block-erase operation. The WSM performs the erase algorithm on the block addressed by the Erase Confirm command. If the next command <i>is not</i> the Erase Confirm (0xD0) command, the CUI sets Status Register bits SR [5,4], and places the device in Read Status Register mode.
	0xD0	Block Erase Confirm	If the first command was Block Erase Setup (0x20), the CUI latches the address and data, and the WSM erases the addressed block. During block-erase operations, the device responds only to Read Status Register and Erase Suspend commands. CE _x or OE# must be toggled to update the Status Register in asynchronous read. CE _x must be toggled to update the SR Data for synchronous Non-array reads.
Suspend	0xB0	Program or Erase Suspend	This command issued to any device address initiates a suspend of the currently-executing program or block erase operation. The Status Register indicates successful suspend operation by setting either SR.2 (program suspended) or SR 6 (erase suspended), along with SR.7 (ready). The WSM remains in the suspend mode regardless of control signal states (except for RPRP# asserted).
	0xD0	Suspend Resume	This command issued to any device address resumes the suspended program or block-erase operation.

Table 7: Command Codes and Definitions (Sheet 2 of 2)

Mode	Code	Device Mode	Description
Protection	0x60	Block lock Setup	First cycle of a 2-cycle command; prepares the CUI for block lock configuration changes. If the next command is not Block Lock (0x01), Block Unlock (0xD0), the CUI sets SR.5 and SR.4, indicating a command sequence error.
	0x01	Block lock	If the previous command was Block Lock Setup (0x60), the addressed block is locked.
	0xD0	Unlock Block	If the previous command was Block Lock Setup (0x60), on issuing this command, all of the Block lock bits that are set are cleared in parallel.
	0xC0	Protection program setup	First cycle of a 2-cycle command; prepares the device for a OTP register or Lock Register program operation. The second cycle latches the register address and data, and starts the programming algorithm to program data the OTP array.
	0xEB	Extended Function Interface (EFI)	This command is used in security features. first cycle of a multiple-cycle command second cycle is a Sub-Op-Code, the data written on third cycle is one less than the word count; the allowable value on this cycle are 0 through 511. The subsequent cycles load data words into the program buffer at a specified address until word count is achieved. For additional information and collateral request, please contact your filed.
STS Configuration	B8h	Configuration Set-Up	Configures the STS pin to different states. The default operation of the STS pin is the level mode, just like RY/BY# which indicates if the Write State Machine is Busy or Available. Using this command the STS pin can be configured to generate an Erase/Program interrupt pulse once the operation is done.
	00h	Configuration Code	Configures the STS pin in level mode. Makes the STS pin function like a RY/BY# pin.
	01h		Configures the STS pin to generate a pulse once an erase operation is completed.
	02h		The STS pin is configured to generate a pulse once a program operation completes.
	03h		The STS pin is configured to generate a pulse when either a program or erase operation completes.

6.2 Device Command Bus Cycle

Device operations are initiated by writing specific device commands to the CUI. See [Table 8, "Command Bus Cycles" on page 19](#). Several commands are used to modify array data including Word Program and Block Erase commands. Writing either command to the CUI initiates a sequence of internally-timed functions that culminate in the completion of the requested task. However, the operation can be aborted by either asserting RP# or by issuing an appropriate suspend command.

Table 8: Command Bus Cycles (Sheet 1 of 2)

Mode	Command	Bus Cycles	First Bus Cycle		Second Bus Cycle		Last Bus Cycle	
			Addr ⁽¹⁾	Data ⁽²⁾	Addr ⁽¹⁾	Data ⁽²⁾	Addr ⁽¹⁾	Data ⁽²⁾
Read	Read Array	1	DnA	0xFF	---	---	---	---
	Read Status Register	2	DnA	0x70	DnA	SRD	---	---
	Read Device Identifier	≥ 2	DnA	0x90	DBA + IA	ID	---	---
	Read CFI	≥ 2	DnA	0x98	DBA + CFI-A	CFI-D	---	---
	Clear Status Register	1	DnA	0x50	---	---	---	---
Program	Word Program	2	WA	0x40	WA	WD	---	---
	Buffered Program ⁽³⁾	> 2	WA	0xE8	WA	N - 1	WA	0xD0

Table 8: Command Bus Cycles (Sheet 2 of 2)

Mode	Command	Bus Cycles	First Bus Cycle		Second Bus Cycle		Last Bus Cycle	
			Addr(1)	Data(2)	Addr(1)	Data(2)	Addr(1)	Data(2)
Erase	Block Erase	2	BA	0x20	BA	0xD0	---	---
Suspend	Program/Erase Suspend	1	DnA	0xB0	---	---	---	---
	Program/Erase Resume	1	DnA	0xD0	---	---	---	---
Protection	Lock Block	2	BA	0x60	BA	0x01	---	---
	Unlock Block	2	BA	0x60	BA	0xD0	---	---
	Program OTP register	2	OTP-RA	0xC0	OTP-RA	OTP-D	---	---
	Program Lock Register	2	LRA	0xC0	LRA	LRD	---	---
	STS Configuration	2	BA	0xB8	BA	Register Data	---	---
	Extended Flash Interface ⁽⁴⁾	> 2	WA	0xEB	WA	Sub-Op code	WA	0xD0

Notes:

1. First command cycle address should be the same as the operation's target address.
 DBA = Device Base Address
 DnA = Address within the device.
 IA = Identification code address offset.
 CFI-A = Read CFI address offset.
 WA = Word address of memory location to be written.
 BA = Address within the block.
 OTP-RA = OTP register address.
 LRA = Lock Register address.
 RCD = Read Configuration Register data on A[15:0].
2. ID = Identifier data.
 CFI-D = CFI data on DQ[15:0].
 SRD = Status Register data.
 WD = Word data.
 N = Word count of data to be loaded into the write buffer.
 OTP-D = OTP register data.
 LRD = Lock Register data.
3. The second cycle of the Buffered Program Command is the word count of the data to be loaded into the write buffer. This is followed by up to 512 words of data. Then the confirm command (0xD0) is issued, triggering the array programming operation.
4. The second cycle is a Sub-Op-Code, the data written on third cycle is N-1; 1=<N<=512. The subsequent cycles load data words into the program buffer at a specified address until word count is achieved, after the data words are loaded, the final cycle is the confirm cycle 0xD0)

7.0 Read operation

The device can be in any of four read states: Read Array, Read Identifier, Read Status Register or Read Query. Upon power-up, or after a reset, the device defaults to Read Array mode. To change the read state, the appropriate read command must be written to the device (see [Section 6.1, "Device Command Codes" on page 18](#)). The following sections describe read-mode operations in detail.

7.1 Read Array

Upon power-up or return from reset, the device defaults to Read Array mode. Issuing the Read Array command places the device in Read Array mode. Subsequent reads output array data on DQ[15:0]. The device remains in Read Array mode until a different read command is issued, or a program or erase operation is performed, in which case, the read mode is automatically changed to Read Status.

To change the device to Read Array mode while it is programming or erasing, first issue the Suspend command. After the operation has been suspended, issue the Read Array command. When the program or erase operation is subsequently resumed, the device will automatically revert back to Read Status mode.

Note: Issuing the Read Array command to the device while it is actively programming or erasing causes subsequent reads from the device to output invalid data. Valid array data is output only after the program or erase operation has finished.

The Read Array command functions independent of the voltage level on VPEN.

7.2 Asynchronous Page Mode Read

J3-65nm supports asynchronous page mode read access only. J3-65nm also supports Byte or Word accesses depending on the level of BYTE#.

- If BYTE# is at V_{IL} then the data will be outputted on the DQ₇₋₀. This read access is called "x8 mode". The DQ₁₅₋₈ signals will be in high-z.
- If BYTE# is at V_{IH} then the data will be outputted on DQ₁₅₋₀. This read access is called "x16 mode."

The default read mode of the device after power up or hardware reset is read array mode. The Read Array/ Software Reset command returns the device to read array mode. Any following read accesses to devices returns main array data.

The page size is sixteen words (32 bytes). Each read operation internally retrieves sixteen words of data, which are determined by addressed bits A[MAX:5]. In x16 mode, the first word of data, defined by A[4:1], is output to the data bus within t_{AVQV} . After this initial access time, subsequent words can be output to the data bus by changing address bits A[4:1]. In x8 mode, the first byte of data, defined by A[4:0], is output to the data bus within t_{AVQV} . After this initial access time, subsequent bytes can be output to the data bus by changing address bits A[4:0]. Any subsequent data word(s) within the page can be output to the data bus within t_{APA} , which is much shorter than t_{AVQV} . The internal read operation can also be initiated by asserting CE_X while addresses are valid or changing the A[MAX:5] while CE_X is asserted.

7.3 Read Status Register

Issuing the Read Status Register command places the device in Read Status Register mode. Subsequent reads output Status Register information on DQ[7:0], and 00h on DQ[15:8]. The device remains in Read Status Register mode until a different read-mode command is issued. Performing a program, erase, or block-lock operation also changes the device's read mode to Read Status Register mode.

The Status Register is updated on the falling edge of CE, or OE# when CE is active. Status Register contents are valid only when SR.7 = 1. When WSM is busy, SR.7 indicates the WSM's state and SR[6:0] are in high-Z state.

The Read Status Register command functions independent of the voltage level on VPEN.

7.4 Read Device Information

Issuing the Read Device Information command places the device in Read Device Information mode. Subsequent reads output device information on DQ[15:0].

The device remains in Read Device Information mode until a different read command is issued. Also, performing a program, erase, or block-lock operation changes the device to Read Status Register mode.

The Read Device Information command functions independent of the voltage level on VPEN.

Table 9: Device Identifier Information

Item	Address ^(1,2,3)	Data
Manufacturer Code	0x00	0x89h
Device ID Code	0x01	ID (see Table 1)
Block Lock Configuration: • Block Is Unlocked • Block Is Locked	BBA + 0x02	Lock Bit: DQ0 = 0b0 DQ0 = 0b1
J3A Block Lock Compatibility	0x03	0x000 ⁽⁴⁾
General Purpose Register ⁽⁵⁾	DBA + 0x07	general data
Lock Register 0	0x80	PR-LK0
64-bit Factory-Programmed OTP register	0x81–0x84	Factory OTP register data
64-bit User-Programmable OTP Register	0x85–0x88	User OTP register data

Notes:

1. BBA = Block Base Address.
2. DBA = Device base Address, Numonyx reserves other configuration address locations
3. A₀ is not used in either x8 or x16 modes during manufacturer and device ID reads. The lowest order address line is A₁.
4. When reading Block Base Address + 00003h, the user needs to read 0000h to be backward compatibly to J3A.
5. The GPR is used as read out register for Extended Functional Interface (EFI) command.

7.5 CFI Query

The CFI query table contains an assortment of flash product information such as block size, density, allowable command sets, electrical specifications, and other product information. The data contained in this table conforms to the CFI protocol.

Issuing the CFI Query command places the device in CFI Query mode. Subsequent reads output CFI information on DQ[15:0]. The device remains in CFI Query mode until a different read command is issued, or a program or erase operation is performed, which changes the read mode to Read Status Register mode.

The CFI Query command functions independent of the voltage level on VPEN.

8.0 Program operation

All programming operations require the addressed block to be unlocked, and a valid VPEN voltage applied throughout the programming operation. Otherwise, the programming operation will abort, setting the appropriate Status Register error bit(s).

The following sections describe each programming method.

8.1 Single-Word/Byte Programming

Array programming is performed by first issuing the Single-Word/Byte Program command. This is followed by writing the desired data at the desired array address. The read mode of the device is automatically changed to Read Status Register mode, which remains in effect until another read-mode command is issued.

During programming, STS and the Status Register indicate a busy status (SR.7 = 0). Upon completion, STS and the Status Register indicate a ready status (SR.7 = 1). The Status Register should be checked for any errors (SR.4), then cleared.

Note: Issuing the Read Array command to the device while it is actively programming causes subsequent reads from the device to output invalid data. Valid array data is output only after the program operation has finished.

Standby power levels are not realized until the programming operation has finished. Also, asserting RP# aborts the programming operation, and array contents at the addressed location are indeterminate. The addressed block should be erased, and the data re-programmed. If a Single-Word/Byte program is attempted when the corresponding block lock-bit is set, SR.1 and SR.4 will be set.

8.2 Buffered Programming

The device features a 512-word buffer to enable optimum programming performance. For Buffered Programming, data is first written to an on-chip write buffer. Then the buffer data is programmed into the flash memory array in buffer-size increments. This can improve system programming performance significantly over non-buffered programming. (see [Figure 19, "Buffer Program Flowchart" on page 59](#)).

When the Buffered Programming Setup command is issued, Status Register information is updated and reflects the availability of the buffer. SR.7 indicates buffer availability: if set, the buffer is available; if cleared, the buffer is not available. To retry, issue the Buffered Programming Setup command again, and re-check SR.7. When SR.7 is set, the buffer is ready for loading.

On the next write, a word count is written to the device at the buffer address. This tells the device how many data words will be written to the buffer, up to the maximum size of the buffer.

On the next write, a device start address is given along with the first data to be written to the flash memory array. Subsequent writes provide additional device addresses and data. All data addresses must lie within the start address plus the word count.

Optimum programming performance and lower power usage are obtained by aligning the starting address at the beginning of a 512-word boundary (A[9:1] = 0x00). The maximum buffer size would be 256-word if the misaligned address range is crossing a 512-word boundary during programming.

After the last data is written to the buffer, the Buffered Programming Confirm command must be issued to the original block address. The WSM begins to program buffer contents to the flash memory array. If a command other than the Buffered

Programming Confirm command is written to the device, a command sequence error occurs and SR[7,5,4] are set. If an error occurs while writing to the array, the device stops programming, and SR[7,4] are set, indicating a programming failure.

When Buffered Programming has completed, additional buffer writes can be initiated by issuing another Buffered Programming Setup command and repeating the buffered program sequence.

If an attempt is made to program past an erase-block boundary using the Buffered Program command, the device aborts the operation. This generates a command sequence error, and SR[5,4] are set.

If Buffered programming is attempted while VPEN is below V_{PENLK} , SR[4,3] are set. If any errors are detected that have set Status Register bits, the Status Register should be cleared using the Clear Status Register command.

Note: In x8 mode, a maximum of 256 bytes of data can be loaded into the write buffer as N can have a max value of FFh.

8.3 Suspend/Resume

An erase or programming operation can be suspended to perform other operations, and then subsequently resumed. Please refer to [Chapter 9.0, "Suspend/Resume"](#) for details.

9.0 Erase Operation

Flash erasing is performed on a block basis. An entire block is erased each time an erase command sequence is issued, and only one block is erased at a time. When a block is erased, all bits within that block read as logical ones. The following sections describe block erase operations in detail.

9.1 Block Erase

Erasing a block changes 'zeros' to 'ones'. To change ones to zeros, a program operation must be performed (see [Section 8.0, "Program operation"](#)). Erasing is performed on a block basis - an entire block is erased each time an erase command sequence is issued. Once a block is fully erased, all addressable locations within that block read as logical ones (FFFFh). Only one block-erase operation can occur at a time, and *is not* permitted during a program suspend (see [Figure 21, "Block Erase Flowchart" on page 61](#)).

Note: A block-erase operation requires the addressed block to be unlocked, and a valid voltage applied to VPEN throughout the block-erase operation. Otherwise, the operation will abort, setting the appropriate Status Register error bit(s).

The Erase Confirm command latches the address of the block to be erased. The addressed block is preconditioned (programmed to all zeros), erased, and then verified. The read mode of the device is automatically changed to Read Status Register mode, and remains in effect until another read-mode command is issued.

During a block-erase operation, STS and the Status Register indicates a busy status (SR.7 = 0). Upon completion, STS and the Status Register indicates a ready status (SR.7 = 1). The Status Register should be checked for any errors, then cleared. If any errors did occur, subsequent erase commands to the device are ignored unless the Status Register is cleared.

The only valid commands during a block erase operation are Read Status and Erase Suspend. After the block-erase operation has completed, any valid command can be issued.

Note: Issuing the Read Array command to the device while it is actively erasing causes subsequent reads from the device to output invalid data. Valid array data is output only after the block-erase operation has finished.

Standby power levels are not realized until the block-erase operation has finished. Also, asserting RP# aborts the block-erase operation, and array contents at the addressed location are indeterminate. The addressed block should be erased before programming within the block is attempted.

9.2 Suspend/Resume

An erase or programming operation can be suspended to perform other operations, and then subsequently resumed. [Table 8](#) shows the Suspend and Resume command bus-cycles (see [Figure 18, "Program/Erase Suspend/Resume Flowchart" on page 57](#)).

Note: All erase and programming operations require the addressed block to remain unlocked with a valid voltage applied to VPEN throughout the suspend operation. Otherwise, the block-erase or programming operation will abort, setting the appropriate Status Register error bit(s). Also, asserting RP# aborts suspended block-erase and programming operations, rendering array contents at the addressed location(s) indeterminate.

To suspend an on-going erase or program operation, issue the Suspend command to any device address. The program or erase operation suspends at pre-determined points during the operation after a delay of t_{SUSP} . Suspend is achieved when STS (in RY/BY# mode) goes high, $\text{SR}[7,6] = 1$ (erase-suspend) or $\text{SR}[7,2] = 1$ (program-suspend).

Note: Issuing the Suspend command does not change the read mode of the device. The device will be in Read Status Register mode from when the erase or program command was first issued, unless the read mode was changed prior to issuing the Suspend command.

Not all commands are allowed when the device is suspended. Table 10 shows which device commands are allowed during Program Suspend or Erase Suspend.

Table 10: Valid Commands During Suspend

Device Command	Program Suspend	Erase Suspend
STS Configuration	Allowed	Allowed
Read Array	Allowed	Allowed
Read Status Register	Allowed	Allowed
Clear Status Register	Allowed	Allowed
Read Device Information	Allowed	Allowed
CFI Query	Allowed	Allowed
Word/Byte Program	Not Allowed	Allowed
Buffered Program	Not Allowed	Allowed
Block Erase	Not Allowed	Not Allowed
Program Suspend	Not Allowed	Allowed
Erase Suspend	Not Allowed	Not Allowed
Program/Erase Resume	Allowed	Allowed
Lock Block	Not Allowed	Not Allowed
Unlock Block	Not Allowed	Not Allowed
Program OTP Register	Not Allowed	Not Allowed

During Suspend, array-read operations are not allowed in blocks being erased or programmed.

A block-erase under program-suspend is not allowed. However, word-program under erase-suspend is allowed, and can be suspended. This results in a simultaneous erase-suspend/ program-suspend condition, indicated by $\text{SR}[7,6,2] = 1$.

To resume a suspended program or erase operation, issue the Resume command to any device address. The read mode of the device is automatically changed to Read Status Register. The operation continues where it left off, STS (in RY/BY# mode) goes low, and the respective Status Register bits are cleared.

When the Resume command is issued during a simultaneous erase-suspend/ program-suspend condition, the programming operation is resumed first. Upon completion of the programming operation, the Status Register should be checked for any errors, and cleared. The resume command must be issued again to complete the erase operation. Upon completion of the erase operation, the Status Register should be checked for any errors, and cleared.

10.0 Security

J3-65nm device offer both hardware and software security features. Block lock operations, PRs and VPEN allow users to implement various levels of data protection.

10.1 Normal Block Locking

J3-65nm has the unique capability of Flexible Block Locking (locked blocks remain locked upon reset or power cycle): All blocks are unlocked at Numonyx factory. Blocks can be locked individually by issuing the Set Block Lock Bit command sequence to any address within a block. Once locked, blocks remain locked when power is removed, or when the device is reset (see [Figure 20, "Block Lock Operations Flowchart" on page 60](#)).

All locked blocks are unlocked simultaneously by issuing the Clear Block Lock Bits command sequence to any device address. Locked blocks cannot be erased or programmed. [Table 8](#) summarizes the command bus-cycles.

After issuing the Set Block Lock Bit setup command or Clear Block Lock Bits setup command, the device's read mode is automatically changed to Read Status Register mode. After issuing the confirm command, completion of the operation is indicated by STS (in RY/BY# mode) going high and SR.7 = 1.

Blocks cannot be locked or unlocked while programming or erasing, or while the device is suspended. Reliable block lock and unlock operations occur only when V_{CC} and V_{PEN} are valid. When $V_{PEN} \leq V_{PENLK}$, block lock-bits cannot be changed.

When the set lock-bit operation is complete, SR.4 should be checked for any error. When the clear lock-bit operation is complete, SR.5 should be checked for any error. Errors bits must be cleared using the Clear Status Register command.

Block lock-bit status can be determined by first issuing the Read Device Information command, and then reading from <block base address> + 02h. DQ0 indicates the lock status of the addressed block (0 = unlocked, 1 = locked).

10.2 Configurable Block Locking

One of the unique new features on the J3-65nm, which did not exist on the previous generations of this product family, is the ability to protect and/or secure the user's system by offering multiple level of securities: Non-Volatile Temporary; Non-Volatile Semi-Permanent or Non-Volatile Permanent. For additional information and collateral request, please contact your field representative .

10.3 VPEN Protection

When it's necessary to protect the entire array, global protection can be achieved using a hardware mechanism using VPEN. Whenever a valid voltage is present on VPEN, blocks within the main flash array can be erased or programmed. By grounding VPEN, blocks within the main array cannot be altered – attempts to program or erase blocks will fail resulting in the setting of the appropriate error bit in the Status Register. By holding VPEN low, absolute write protection of all blocks in the array can be achieved.

10.4 Password Access

Password Access is a security enhancement offered on the J3-65nm device. This feature protects information stored in main-array memory blocks by preventing content alteration or reads, until a valid 64-bit password is received. Password Access may be combined with Non-Volatile Protection and/or Volatile Protection to create a multi-tiered solution.

Please contact your Numonyx Sales for further details concerning Password Access.

11.0 Registers

11.1 Status Register

The Status Register (SR) is an 8-bit, read-only register that indicates device status and operation errors. To read the Status Register, issue the Read Status Register command. Subsequent reads output Status Register information on DQ[7:0], and 00h on DQ[15:8].

SR *status bits* are set and cleared by the device. SR *error bits* are set by the device, but must be cleared using the Clear Status Register command. Upon power-up or exit from reset, the Status Register defaults to 80h. Page-mode reads are not supported in this read mode. Status Register contents are latched on the falling edge of OE# or the first edge of CEx that enables the device. OE# must toggle to V_{IH} or the device must be disabled before further reads to update the Status Register latch. The Read Status Register command functions independently of V_{PEN} voltage.

Table 11 shows Status Register bit definitions.

Table 11: Status Register Description

Status Register (SR)			Default Value = 0x80				
Device Write Status	Erase Suspend Status	Erase Status	Program Status	Prog/Erase Voltage Error	Program Suspend Status	Block-Locked Status	Reserved
DWS	ESS	ES	PS	PEVE	PSS	BLS	
7	6	5	4	3	2	1	0
Bit	Name	Description					
7	Device Write Status (DWS)	0 = Device is busy; program or erase cycle in progress. 1 = Device is ready; SR[6:1] are valid.					
6	Erase Suspend Status (ESS)	0 = Erase suspend not in effect. 1 = Erase suspend in effect.					
5	Erase Status (ES)	0 = Erase successful. 1 = Erase fail or program sequence error when set with SR.4,SR.7.					
4	Program Status (PS)	0 = Program successful. 1 = Program fail or program sequence error when set with SR.5,SR.7					
3	Prog/Erase Voltage Error (PEVE)	0 = VPEN within acceptable limits during program or erase operation. 1 = VPEN ≤ VPENLK during program or erase operation.					
2	Program Suspend Status (PSS)	0 = Program suspend not in effect. 1 = Program suspend in effect.					
1	Block-Locked Status (BLS)	0 = Block not locked during program or erase. 1 = Block locked during program or erase; operation aborted.					
0	Reserved	0 = Default					
<p>Note: Always clear the Status Register prior to resuming erase operations. It avoids Status Register ambiguity when issuing commands during Erase Suspend. If a command sequence error occurs during an erase-suspend state, the Status Register contains the command sequence error status (SR[7,5,4] set). When the erase operation resumes and finishes, possible errors during the erase operation cannot be detected via the Status Register because it contains the previous error status</p>							

11.1.1 Clearing the Status Register

The Clear Status Register command clears the status register. It functions independent of VPEN. The WSM sets and clears SR[7,6,2], but it sets bits SR[5:3,1] without clearing them. The Status Register should be cleared before starting a command sequence to avoid any ambiguity. A device reset also clears the Status Register.

11.2 Status Signal

The STATUS (STS) signal can be configured to different states using the STS Configuration command (Table 12). Once the STS signal has been configured, it remains in that configuration until another Configuration command is issued or RP# is asserted low. Initially, the STS signal defaults to RY/BY# operation where RY/BY# low indicates that the WSM is busy. RY/BY# high indicates that the state machine is ready for a new operation or suspended. Table 12 displays possible STS configurations.

To reconfigure the STATUS (STS) signal to other modes, the Configuration command is given followed by the desired configuration code. The three alternate configurations are all pulse mode for use as a system interrupt as described in the following paragraphs. For these configurations, bit 0 controls Erase Complete interrupt pulse, and bit 1 controls Program Complete interrupt pulse. Supplying the 00h configuration code with the Configuration command resets the STS signal to the default RY/BY# level mode. The Configuration command may only be given when the device is not busy or suspended. Check SR.7 for device status. An invalid configuration code will result in SR.4 and SR.5 being set.

Note: STS Pulse mode is not supported in the Clear Lock Bits and Set Lock Bit commands.

Table 12: STS Configuration Coding Definitions

D7	D6	D5	D4	D3	D2	D1	D0
Reserved ³						Pulse on Program Complete (1)	Pulse on Erase Complete (1)
D[1:0] = STS Configuration Codes				Notes			
00 = default, level mode; device ready indication				Controls HOLD to a memory controller to prevent accessing a flash memory subsystem while any flash device's WSM is busy.			
01 = pulse on Erase Complete				Generates a system interrupt pulse when any flash device in an array has completed a block erase. Helpful for reformatting blocks after file system free space reclamation or "cleanup."			
10 = pulse on Program Complete				Generate a system interrupt pulse when any flash device in an array has complete a Program operation. Provides highest performance for servicing continuous buffer write operations.			
11 = pulse on Erase or Program Complete				Generates system interrupts to trigger servicing of flash arrays when either erase or program operations are completed, when a common interrupt service routine is desired.			

Notes:

1. When configured in one of the pulse modes, STS pulses low with a typical pulse width of 500 ns.
2. An invalid configuration code will result in both SR.4 and SR.5 being set.
3. Reserved bits are invalid should be ignored.

11.3 OTP Protection Register

J3-65nm includes a 128-bit Protection Register (PR) that can be used to increase the security of a system design. For example, the number contained in the PR can be used to "match" the flash component with other system components such as the CPU or ASIC, hence preventing device substitution.

The 128-bits of the PR are divided into two 64-bit segments:

- One segment is programmed at the Numonyx factory with a unique unalterable 64-bit number.
- The other segment is left blank for customer designers to program as desired. Once the customer segment is programmed, it can be locked to prevent further programming.

11.3.1 Reading the OTP Protection Register

The Protection Register is read in Identification Read mode. The device is switched to this mode by issuing the Read Identifier command (0090h). Once in this mode, read cycles from addresses shown in [Table 13, "Word-Wide Protection Register Addressing"](#) or [Table 14, "Byte-Wide Protection Register Addressing"](#) retrieve the specified information. To return to Read Array mode, write the Read Array command (00FFh).

11.3.2 Programming the OTP Protection Register

PR bits are programmed using the two-cycle Protection Program command. The 64-bit number is programmed 16 bits at a time for word-wide configuration and eight bits at a time for byte-wide configuration. First write the Protection Program Setup command, 00C0h. The next write to the device will latch in address and data and program the specified location. The allowable addresses are shown in [Table 13, "Word-Wide](#)

Protection Register Addressing” on page 33 or Table 14, “Byte-Wide Protection Register Addressing” on page 34. See Figure 22, “OTP Register Programming Flowchart” on page 62. Any attempt to address Protection Program commands outside the defined PR address space will result in a Status Register error (SR.4 will be set). Attempting to program a locked PR segment will result in a Status Register error (SR.4 and SR.1 will be set).

11.3.3 Locking the OTP Protection Register

The user-programmable segment of the PR is lockable by programming Bit 1 of the Protection Lock Register (PLR) to 0. Bit 0 of this location is programmed to 0 at the Numonyx factory to protect the unique device number. Bit 1 is set using the Protection Program command to program “0xFFFD” to the PLR. After these bits have been programmed, no further changes can be made to the values stored in the Protection Register. Protection Program commands to a locked section will result in a Status Register error (SR.4 and SR.1 will be set). The PR lockout state is not reversible.

Figure 6: Protection Register Memory Map

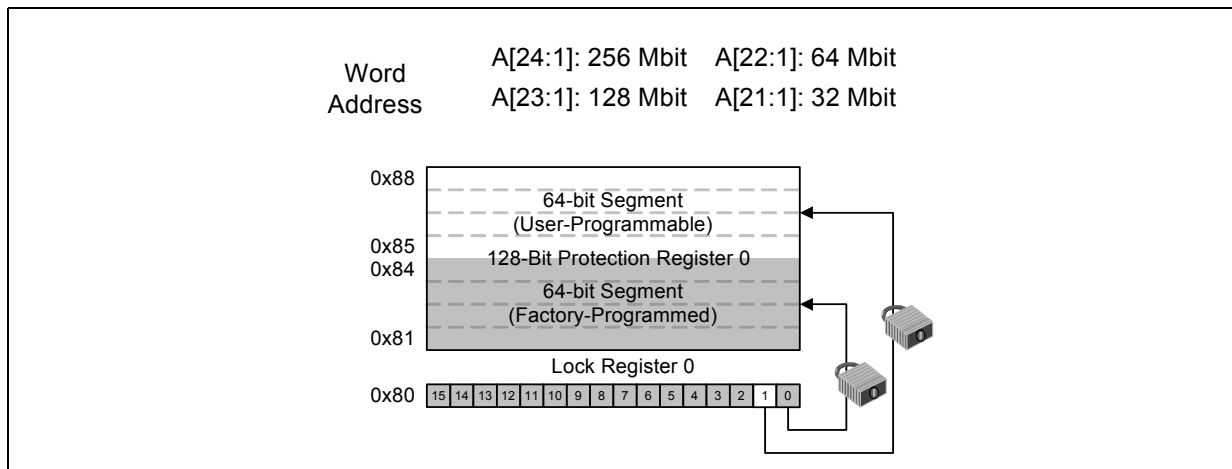

Note: A0 is not used in x16 mode when accessing the protection register map. See Table 13 for x16 addressing. In x8 mode A0 is used, see Table 14 for x8 addressing.

Table 13: Word-Wide Protection Register Addressing

Word	Use	A8	A7	A6	A5	A4	A3	A2	A1
LOCK	Both	1	0	0	0	0	0	0	0
0	Factory	1	0	0	0	0	0	0	1
1	Factory	1	0	0	0	0	0	1	0
2	Factory	1	0	0	0	0	0	1	1
3	Factory	1	0	0	0	0	1	0	0
4	User	1	0	0	0	0	1	0	1
5	User	1	0	0	0	0	1	1	0
6	User	1	0	0	0	0	1	1	1
7	User	1	0	0	0	1	0	0	0

Note: All address lines not specified in the above table must be 0 when accessing the Protection Register (i.e., A[MAX:9] = 0.)

Table 14: Byte-Wide Protection Register Addressing

Byte	Use	A8	A7	A6	A5	A4	A3	A2	A1	A0
LOCK	Both	1	0	0	0	0	0	0	0	0
LOCK	Both	1	0	0	0	0	0	0	0	1
0	Factory	1	0	0	0	0	0	0	1	0
1	Factory	1	0	0	0	0	0	0	1	1
2	Factory	1	0	0	0	0	0	1	0	0
3	Factory	1	0	0	0	0	0	1	0	1
4	Factory	1	0	0	0	0	0	1	1	0
5	Factory	1	0	0	0	0	0	1	1	1
6	Factory	1	0	0	0	0	1	0	0	0
7	Factory	1	0	0	0	0	1	0	0	1
8	User	1	0	0	0	0	1	0	1	0
9	User	1	0	0	0	0	1	0	1	1
A	User	1	0	0	0	0	1	1	0	0
B	User	1	0	0	0	0	1	1	0	1
C	User	1	0	0	0	0	1	1	1	0
D	User	1	0	0	0	0	1	1	1	1
E	User	1	0	0	0	1	0	0	0	0
F	User	1	0	0	0	1	0	0	0	1

Note: All address lines not specified in the above table must be 0 when accessing the Protection Register, i.e., A[MAX:9] = 0.

12.0 Power and Reset Specifications

12.1 Power-Up and Power-Down

Power supply sequencing is not required if VPEN is connected to VCC or VCCQ. Otherwise VCC and VCCQ should attain their minimum operating voltage before applying VPEN.

Power supply transitions should only occur when RP# is low. This protects the device from accidental programming or erasure during power transitions.

12.1.1 Power-Up/Down Characteristics

To prevent conditions that could result in spurious program or erase operations, several valid power-up/power-down sequences shown in Table 15 are recommended. For DC voltage characteristics refer to Table 20. Note that each power supply must reach its minimum voltage range before applying/removing the next supply voltage.

Table 15: Power-Up/Down Sequence

Power Supply Voltage	Power-Up Sequence				Power-Down Sequence			
V _{CC} (min)	1st	1st	1st [†]	Sequencing not required [†]	3rd	2nd	2nd [†]	Sequencing not required [†]
V _{CCQ} (min)	2nd	2nd [†]			2nd	1st [†]		
V _{PEN} (min)	3rd		2nd		1st		1st	

Note: Power supplies connected or sequenced together.

Device inputs must not be driven until all supply voltages reach their minimum range. RP# should be low during power transitions.

12.2 Reset Specifications

Asserting RP# during a system reset is important with automated program/erase devices because systems typically expect to read from flash memory when coming out of reset. If a CPU reset occurs without a flash memory reset, proper CPU initialization may not occur. This is because the flash memory may be providing status information, instead of array data as expected. Connect RP# to the same active low reset signal used for CPU initialization.

Also, because the device is disabled when RP# is asserted, it ignores its control inputs during power-up/down. Invalid bus conditions are masked, providing a level of memory protection.

Table 16: Power and Reset

Num	Symbol	Parameter	Min	Max	Unit	Notes
P1	t _{PLPH}	RP# pulse width low	100	-	ns	1,2,3,4
P2	t _{PLRH}	RP# low to device reset during erase	-	25	μs	1,3,4,7
		RP# low to device reset during program	-	25		1,3,4,7
P3	t _{VCCPH}	VCC Power valid to RP# de-assertion (high)	300	-		1,4,5,6

Notes:

1. These specifications are valid for all device versions (packages and speeds).
2. The device may reset if t_{PLPH} is < t_{PLPH} Min, but this is not guaranteed.
3. Not applicable if RP# is tied to VCC.
4. Sampled, but not 100% tested.
5. When RP# is tied to the VCC supply, device will not be ready until t_{VCCPH} after VCC ≥ V_{CCMIN}.
6. When RP# is tied to the VCCQ supply, device will not be ready until t_{VCCPH} after VCC ≥ V_{CCMIN}.
7. Reset completes within t_{PLPH} if RP# is asserted while no erase or program operation is executing.

Figure 7: Reset Operation Waveforms

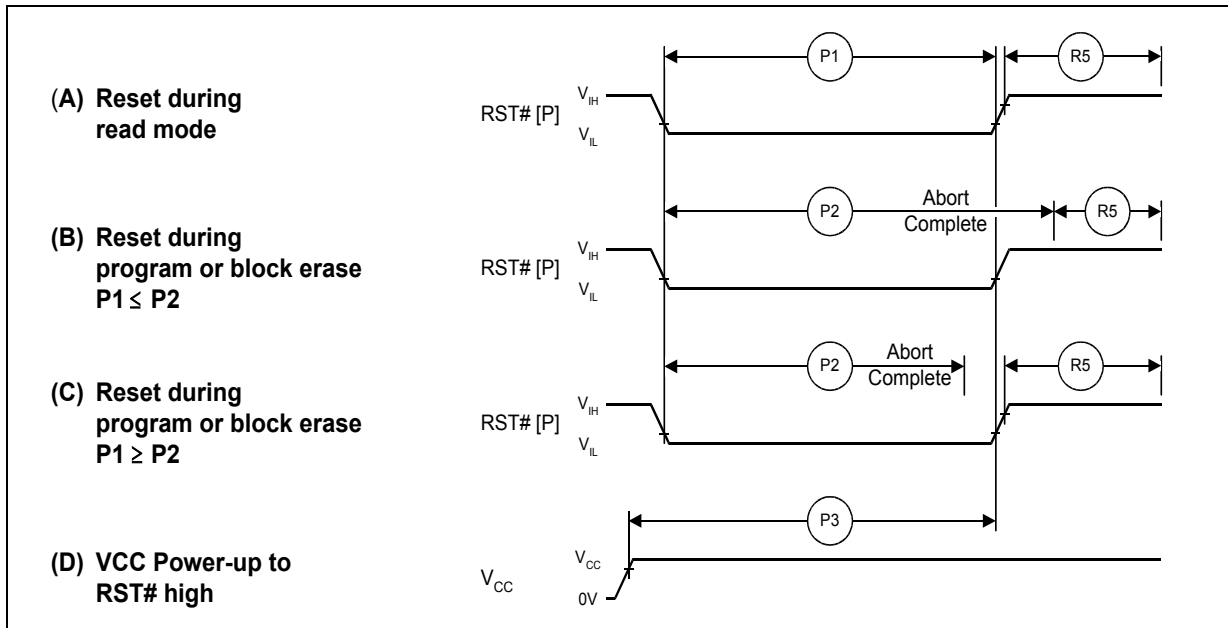

12.3 Power Supply Decoupling

Flash memory devices require careful power supply de-coupling. Three basic power supply current considerations are: 1) standby current levels; 2) active current levels; and 3) transient peaks produced when CE_x and OE# are asserted and deasserted.

When the device is accessed, many internal conditions change. Circuits within the device enable charge-pumps, and internal logic states change at high speed. All of these internal activities produce transient signals. Transient current magnitudes depend on the device outputs' capacitive and inductive loading. Two-line control and correct de-coupling capacitor selection suppress transient voltage peaks.

Because Numonyx MLC flash memory devices draw their power from VCC, VSS, and VCCQ, each power connection should have a 0.1 μF ceramic capacitor to ground. High-frequency, inherently low-inductance capacitors should be placed as close as possible to package leads.

Additionally, for every eight devices used in the system, a 4.7 μF electrolytic capacitor should be placed between power and ground close to the devices. The bulk capacitor is meant to overcome voltage droop caused by PCB trace inductance.

13.0 Maximum Ratings and Operating Conditions

13.1 Absolute Maximum Ratings

Warning: Stressing the device beyond the “Absolute Maximum Ratings” may cause permanent damage. These are stress ratings only.

NOTICE: This document contains information available at the time of its release. The specifications are subject to change without notice. Verify with your local Numonyx sales office that you have the latest datasheet before finalizing a design.

Table 17: Absolute Maximum Ratings

Parameter	Min	Max	Unit	Notes
Temperature under Bias Expanded (T_A , Ambient)	-40	+85	°C	—
Storage Temperature	-65	+125	°C	—
V_{CC} & V_{CCQ} Voltage	-2.0	+5.6	V	2
Voltage on any input/output signal (except V_{CC} , V_{CCQ})	-2.0	$V_{CCQ}(\text{max}) + 2.0$	V	1
I_{SH} Output Short Circuit Current	—	100	mA	3

Notes:

1. Voltage is referenced to V_{SS} . During infrequent non-periodic transitions, the voltage potential between V_{SS} and input/output pins may undershoot to -2.0 V for periods < 20 ns or overshoot to $V_{CCQ}(\text{max}) + 2.0$ V for periods < 20 ns.
2. During infrequent non-periodic transitions, the voltage potential between V_{CC} and the supplies may undershoot to -2.0 V for periods < 20 ns or $V_{SUPPLY}(\text{max}) + 2.0$ V for periods < 20 ns.
3. Output shorted must be no more than one second. No more than one output can be shorted at a time.

13.2 Operating Conditions

Warning: Operation beyond the “Operating Conditions” is not recommended and extended exposure beyond the “Operating Conditions” may affect device reliability

Table 18: Temperature and V_{CC} Operating Condition

Symbol	Parameter	Min	Max	Unit	Test Condition
T_A	Operating Temperature (Ambient)	-40	+85	°C	Ambient Temperature
V_{CC}	V_{CC} Supply Voltage	2.7	3.6	V	—
V_{CCQ}	I/O Supply Voltage	2.7	3.6	V	—
Block Erase Cycles	Main Blocks	100k	—	Cycles	—

14.0 Electrical characteristics

14.1 DC Current Specifications

Please refer to [Figure 6, "Chip Enable Truth Table for 256-Mb"](#) on page 15 to understand the device is disable or enabled.

Table 19: DC Current Characteristics

Symbol	Parameter	Density	2.7 - 3.6V			Test Conditions	Notes
			Typ	Max	Unit		
I_{LI}	Input and V_{PEN} Load Current		—	± 1	μA	$V_{CC} = V_{CCMAX}$ $V_{CCQ} = V_{CCQMAX}$ $V_{IN} = V_{CCQ}$ or V_{SS}	1
I_{LO}	Output Leakage Current		—	± 1			
I_{CCS} , I_{CCD}	V_{CC} Standby Current, V_{CC} Power-Down Current	256-Mbit	65	210	μA	$V_{CC} = V_{CCMAX}$ $V_{CCQ} = V_{CCQMAX}$ $CE\# = V_{CCQ}$ $RP\# = V_{CCQ}$ (for I_{CCS}) $RP\# = V_{SS}$ (for I_{CCD})	1,2,3
I_{CCR}	V_{CC} Page Mode Read Current	Single Word	26	31	mA	$V_{CC} = V_{CCMAX}$ $CE\# = V_{IL}$ $OE\# = V_{IH}$ Inputs: V_{IH} or V_{IL} $f = 5MHz$ (1 CLK)	1
		Page	12	16	mA	$V_{CC} = V_{CCMAX}$ $CE\# = V_{IL}$ $OE\# = V_{IH}$ Inputs: V_{IH} or V_{IL} $f = 13MHz$ (17 CLK)	
I_{CCW} , I_{CCE}	V_{CC} Program, V_{CC} Erase		35	50	mA	$V_{PEN} = V_{PENH}$, program/erase in progress	1,3
I_{CCWS} I_{CCES}	V_{CC} Program Suspend V_{CC} Erase Suspend		Refer to I_{CCS}		μA	$CE\# = V_{CCQ}$, suspend in progress	1,4
<p>Notes:</p> <ol style="list-style-type: none"> All currents are in RMS unless otherwise noted. These currents are valid for all product versions (packages and speeds). Includes STS. Sampled, not 100% tested. I_{CCWS} and I_{CCES} are specified with the device selected. If the device is read or written while in erase suspend mode, the device's current draw is I_{CCR} and I_{CCWS}. 							

14.2 DC Voltage Specifications

Table 20: DC Voltage Characteristics

Symbol	Parameter	2.7 - 3.6 V			Test Conditions	Notes
		Min	Max	Unit		
V _{IL}	Input Low Voltage	-0.5	0.6	V		2, 5, 6
V _{IH}	Input High Voltage	2.0	V _{CCQ} + 0.5V	V		2, 5, 6
V _{OL}	Output Low Voltage	—	0.4	V	V _{CC} = V _{CCMin} V _{CCQ} = V _{CCQ Min} I _{OL} = 2 mA	1, 2
		—	0.2	V	V _{CC} = V _{CCMin} V _{CCQ} = V _{CCQ Min} I _{OL} = 100 μA	
V _{OH}	Output High Voltage	0.85 × V _{CCQ}	—	V	V _{CC} = V _{CCMin} V _{CCQ} = V _{CCQ Min} I _{OH} = -2.5 mA	1, 2
		V _{CCQ} - 0.2	—	V	V _{CC} = V _{CCMin} V _{CCQ} = V _{CCQ Min} I _{OH} = -100 μA	
V _{PENLK}	V _{PEN} Lockout during Program, Erase and Lock-Bit Operations	—	2.2	V		2, 3
V _{PENH}	V _{PEN} during Block Erase, Program, or Lock-Bit Operations	2.7	3.6	V		3
V _{LKO}	V _{CC} Lockout Voltage	1.5	—	V		4
V _{LKOQ}	V _{CCQ} Lockout Voltage	0.9	—	V		

Notes:

- Includes STS.
- Sampled, not 100% tested.
- Block erases, programming, and lock-bit configurations are inhibited when V_{PEN} ≤ V_{PENLK}, and not guaranteed in the range between V_{PENLK} (max) and V_{PENH} (min), and above V_{PENH} (max).
- Block erases, programming, and lock-bit configurations are inhibited when V_{CC} < V_{LKO}, and not guaranteed in the range between V_{LKO} (min) and V_{CC} (min), and above V_{CC} (max).
- Includes all operational modes of the device including standby and power-up sequences
- Input/Output signals can undershoot to -1.0V referenced to V_{SS} and can overshoot to V_{CCQ} + 1.0V for duration of 2ns or less, the V_{CCQ} valid range is referenced to V_{SS}.

14.3 Capacitance

Table 21: Capacitance

Symbol	Parameter	Signals	Min	Typ	Max	Unit	Condition	Note
C _{IN}	Input Capacitance	Address, Data, CE#, WE#, OE#, BYTE#, RP#	2	6	7	pF	Typ temp = 25 °C, Max temp = 85 °C, V _{CC} = (0 V - 3.6 V), V _{CCQ} = (0 V - 3.6 V), Discrete silicon die	1,2,3
C _{OUT}	Output Capacitance	Data, STS	2	4	5	pF		

Notes:

- Capacitance values are for a single die.
- Sampled, not 100% tested.
- Silicon die capacitance only, add 1 pF for discrete packages.

15.0 AC characteristics

Timing symbols used in the timing diagrams within this document conform to the following convention

Figure 8: Timing Signal Naming Convention

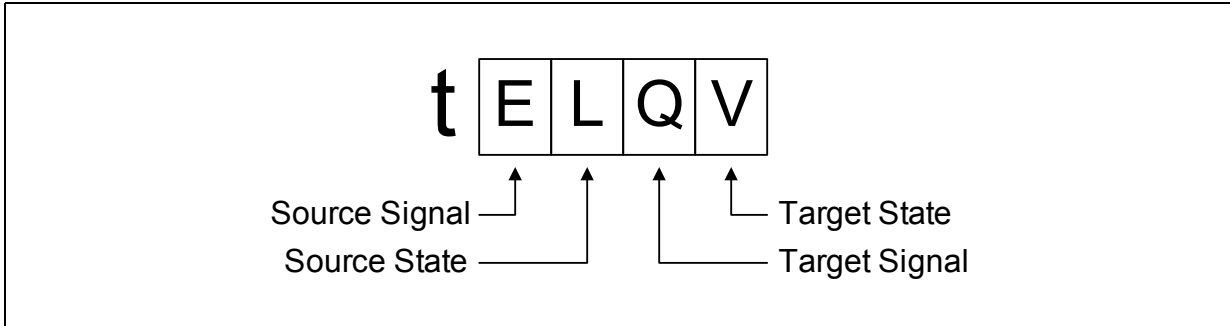

Figure 9: Timing Signal Name Decoder

Signal	Code	State	Code
Address	A	High	H
Data - Read	Q	Low	L
Data - Write	D	High-Z	Z
Chip Enable (CE)	E	Low-Z	X
Output Enable (OE#)	G	Valid	V
Write Enable (WE#)	W	Invalid	I
BYTE#	F		
Reset (RP#)	P		
STS	R		
VPEN	V		

Note: Exceptions to this convention include t_{ACC} and t_{APA} . t_{ACC} is a generic timing symbol that refers to the aggregate initial-access delay as determined by t_{AVQV} , t_{ELOV} , and t_{GLQV} (whichever is satisfied last) of the flash device. t_{APA} is specified in the flash device's data sheet, and is the address-to-data delay for subsequent page-mode reads.

15.1 AC Test Conditions

Figure 10: AC Input/Output Reference Waveform

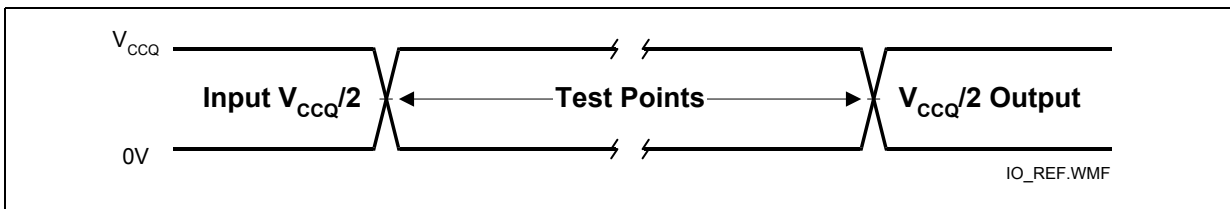

Note: AC test inputs are driven at V_{CCQ} for Logic "1" and $0V$ for Logic "0." Input/output timing begins/ends at $V_{CCQ}/2$. Input rise and fall times (10% to 90%) < 5 ns. Worst-case speed occurs at $V_{CC} = V_{CCMin}$.

Figure 11: Transient Equivalent Testing Load Circuit

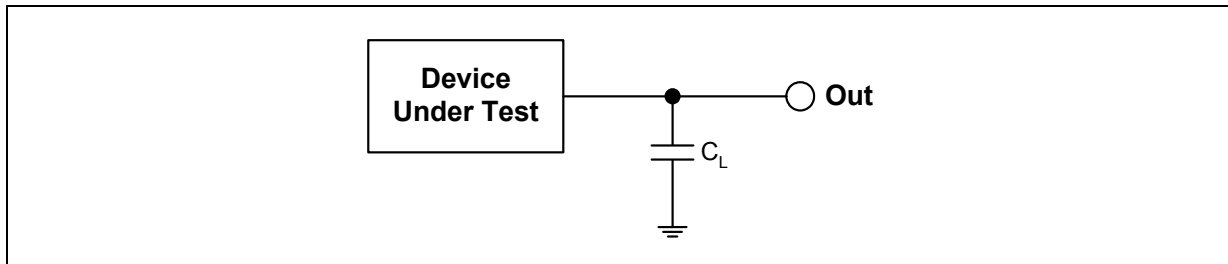

Notes:

1. See the following table for component values.
2. Test configuration component value for worst case speed conditions.
3. C_L includes jig capacitance

Table 22: Test Configuration Component Value for Worst Case Speed Conditions

Test Configuration	C _L (pF)
VCCQ Min Standard Test	30

15.2 AC Read Specifications

Chip enable truth table can be found on [Table 6 on page 15](#)

Test configuration can be found in [Table 22 on page 42](#)

Table 23: AC Read Specification

Nbr.	Symbol	Parameter	Package	Min	Max	Unit	Notes
R1	t _{AVAV}	Read/Write Cycle Time	Easy BGA	95	—	ns	1,2,3
			TSOP	105	—		
R2	t _{AVQV}	Address to Output Delay	Easy BGA	—	95	ns	1,2,3
			TSOP	—	105		
R3	t _{ELQV}	CEX to Output Delay	Easy BGA	—	95	ns	1,2,3
			TSOP	—	105		
R4	t _{GLQV}	OE# to Non-Array Output Delay		—	25	ns	1,2,3
R5	t _{PHQV}	RP# High to Output Delay		—	150	ns	1,2,3
R6	t _{ELQX}	CEX to Output in Low Z		0	—	ns	1,2,3,4
R7	t _{GLQX}	OE# to Output in Low Z		0	—	ns	1,2,3,4
R8	t _{EHQZ}	CEX High to Output in High Z		—	20	ns	1,2,3,4
R9	t _{GHQZ}	OE# High to Output in High Z		—	15	ns	1,2,3,4
R10	t _{OH}	Output Hold from Address, CEX, or OE# Change, Whichever Occurs First		0	—	ns	1,2,3,4
R11	t _{ELFL} /t _{ELFH}	CEX Low to BYTE# High or Low		—	10	ns	1,2,3,4
R12	t _{FLQV} /t _{FHQV}	BYTE# to Output Delay		—	1	µs	1,2,3
R13	t _{FLQZ}	BYTE# to Output in High Z		—	1	µs	1,2,3,4
R14	t _{EHEL}	CEX High to CEX Low		0	—	ns	1,2,3,4
R15	t _{APA}	Page Address Access Time		—	25	ns	4, 5
R16	t _{GLQV}	OE# to Array Output Delay		—	25	ns	1,2,3

Notes:

1. CEX low is defined as the falling edge of CE0, CE1, or CE2 that enables the device. CEX high is defined as the rising edge of CE0, CE1, or CE2 that disables the device
2. See AC Input/Output Reference Waveforms for the maximum allowable input slew rate.
3. OE# may be delayed up to t_{ELQV}-t_{GLQV} after the falling edge of CE0, CE1, or CE2 that enables the device without impact on t_{ELQV}.
4. Sampled, not 100% tested.
5. For devices configured to standard word/byte read mode, R15 (t_{APA}) will equal R2 (t_{AVQV}).

Figure 12: Single Word Asynchronous Read Waveform

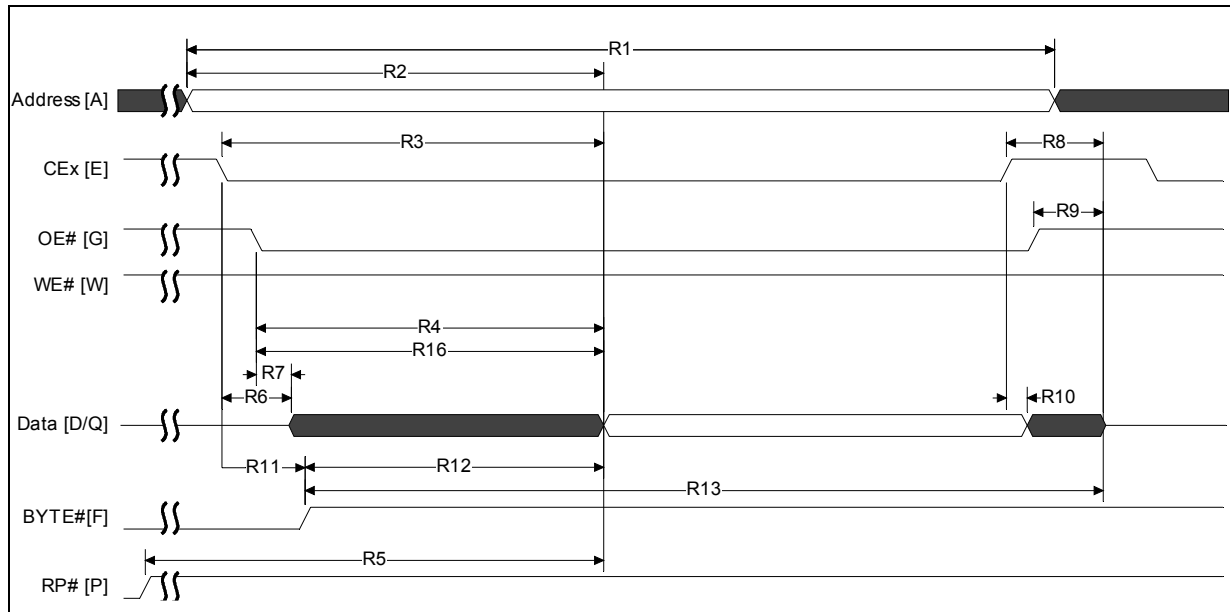

Notes:

1. CE_x low is defined as the falling edge of CE0, CE1, or CE2 that enables the device. CE_x high is defined as the rising edge of CE0, CE1, or CE2 that disables the device.
2. When reading the flash array a faster t_{GLQV} (R16) applies. For non-array reads, R4 applies (i.e., Status Register reads, query reads, or device identifier reads).

Figure 13: 4-Word Asynchronous Page Mode Read Waveform

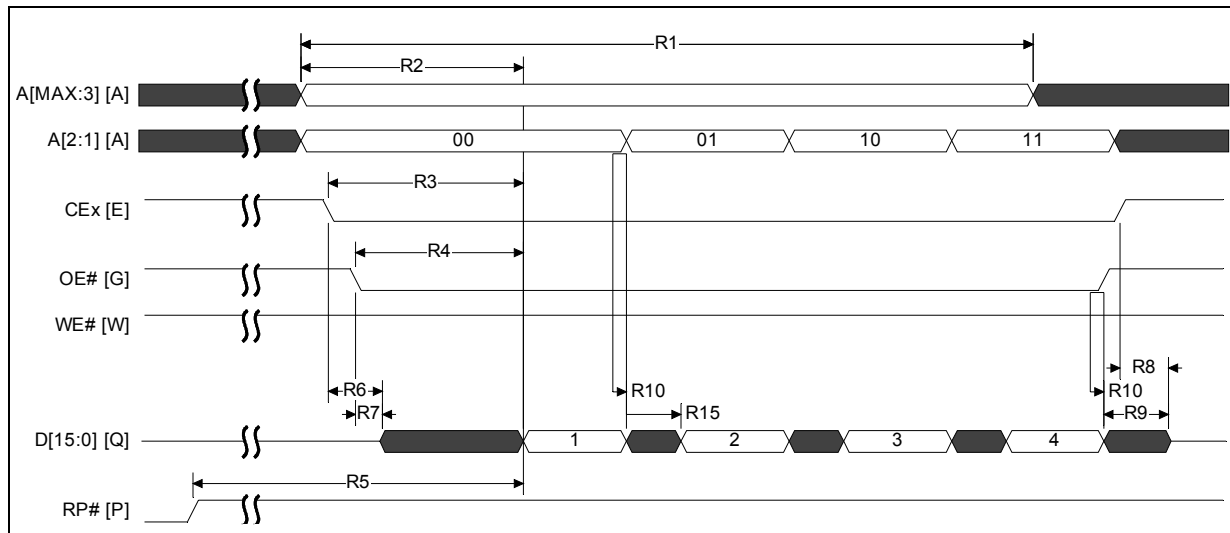

Note:

1. CE_x low is defined as the falling edge of CE0, CE1, or CE2 that enables the device. CE_x high is defined as the rising edge of CE0, CE1, or CE2 that disables the device.
2. In this diagram, BYTE# is asserted high.

Figure 14: 16-Word Asynchronous Page Mode Read

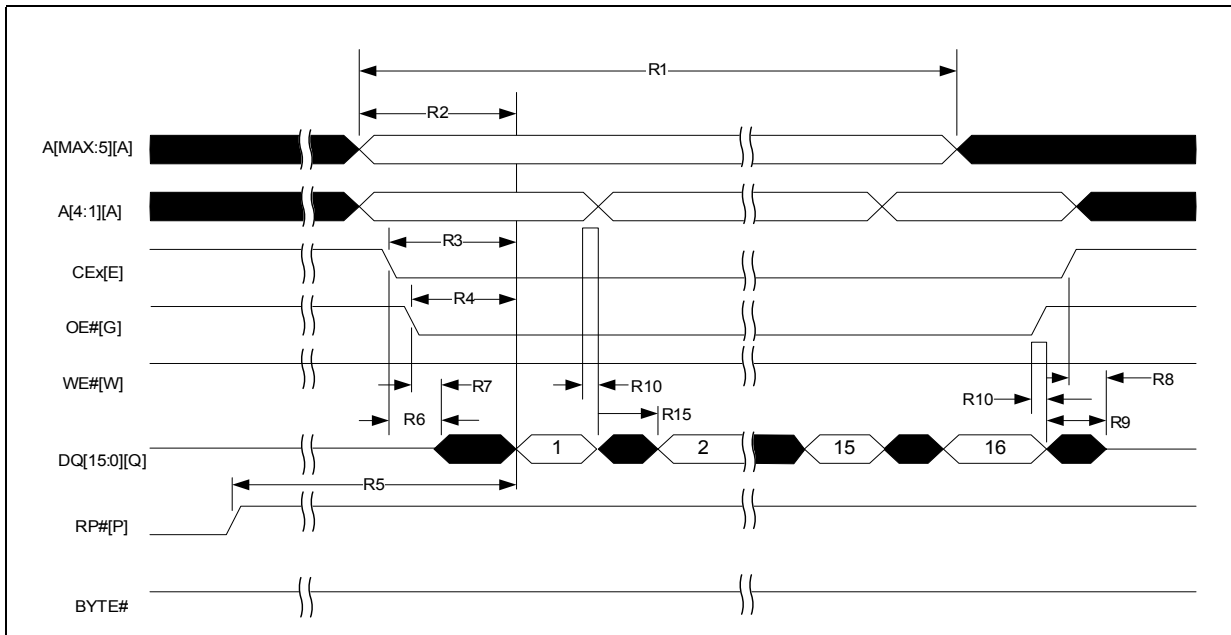

Notes:

1. CE_x low is defined as the falling edge of CE0, CE1, or CE2 that enables the device. CE_x high is defined at the rising edge of CE0, CE1, or CE2 that disables the device.
2. In this diagram, BYTE# is asserted high.

15.3 AC Write Specification

CE_x low is defined as the falling edge of CE0, CE1, or CE2 that enables the device. CE_x high is defined at the rising edge of CE0, CE1, or CE2 that disables the device. Chip enable truth table can be found in [Table 6 on page 15](#)

Table 24: AC Write Specification

Nbr.	Symbol	Parameter	Min	Max	Unit	Notes
W1	t _{PHWL} (t _{PHL})	RP# High Recovery to WE# (CE _x) Going Low	150	—	ns	1,2,3
W2	t _{ELWL} (t _{WLEL})	CE _x (WE#) Low to WE# (CE _x) Going Low	0	—	ns	1,2,4
W3	t _{WP}	Write Pulse Width	50	—	ns	1,2,4
W4	t _{DVWH} (t _{DVEH})	Data Setup to WE# (CE _x) Going High	50	—	ns	1,2
W5	t _{AVWH} (t _{AVEH})	Address Setup to WE# (CE _x) Going High	50	—	ns	1,2
W6	t _{WHEH} (t _{EHWH})	CE _x (WE#) Hold from WE# (CE _x) High	0	—	ns	1,2,
W7	t _{WHDX} (t _{EHDX})	Data Hold from WE# (CE _x) High	0	—	ns	1,2,
W8	t _{WHAX} (t _{EHAX})	Address Hold from WE# (CE _x) High	0	—	ns	1,2,
W9	t _{WPH}	Write Pulse Width High	20	—	ns	1,2,5
W11	t _{VPWH} (t _{VPEH})	V _{PEN} Setup to WE# (CE _x) Going High	0	—	ns	1,2,3
W14	t _{WHGL} (t _{EHGL})	Write Recovery before Read	0	—	ns	1,2,6
W13	t _{WHRL} (t _{EHRL})	WE# (CE _x) High to STS Going Low	—	500	ns	1,2,7
W15	t _{QVVL}	V _{PEN} Hold from Valid SRD, STS Going High	0	—	ns	1,2,3,7,8

Notes:

1. Read timing characteristics during block erase, program, and lock-bit configuration operations are the same as during read-only operations. Refer to *AC Characteristics-Read-Only Operations*.
2. A write operation can be initiated and terminated with either CE_x or WE#.
3. Sampled, not 100% tested.
4. Write pulse width (t_{WP}) is defined from CE_x or WE# going low (whichever goes low last) to CE_x or WE# going high (whichever goes high first). Hence, t_{WP} = t_{WLWH} = t_{ELEH} = t_{WLEH} = t_{ELWH}.
5. Write pulse width high (t_{WPH}) is defined from CE_x or WE# going high (whichever goes high first) to CE_x or WE# going low (whichever goes low first). Hence, t_{WPH} = t_{WHWL} = t_{EHEL} = t_{WHEL} = t_{EHWL}.
6. For array access, t_{AVQV} is required in addition to t_{WHGL} for any accesses after a write.
7. STS timings are based on STS configured in its RY/BY# default mode.
8. V_{PEN} should be held at V_{PENH} until determination of block erase, program, or lock-bit configuration success (SR[5:3,1] = 0).

Figure 15: Asynchronous Write Waveform

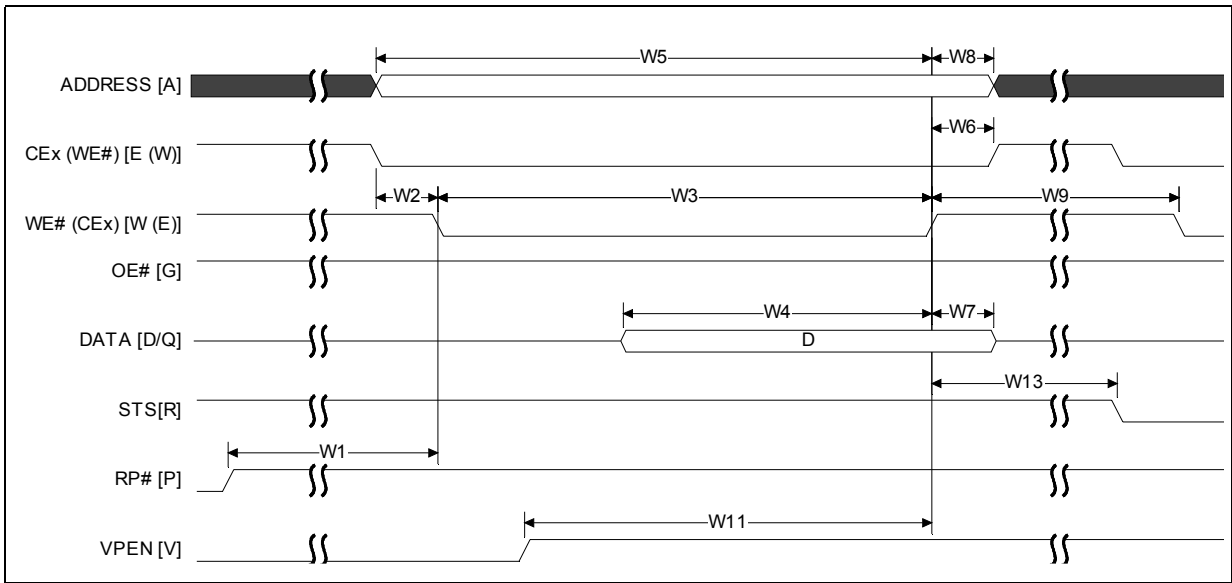
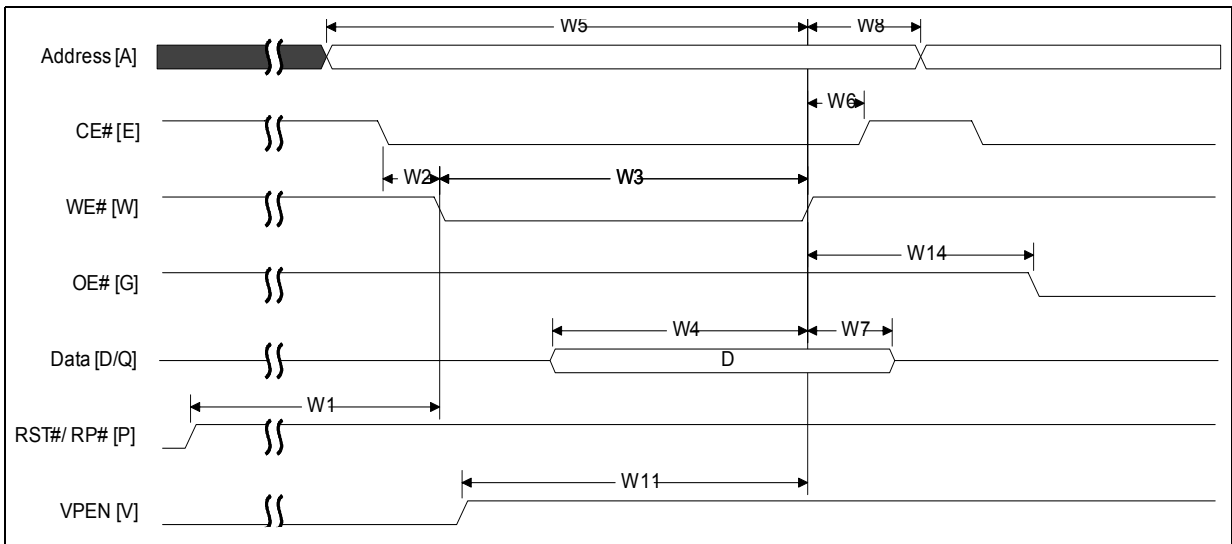

Figure 16: Asynchronous Write to Read Waveform



16.0 Program and erase characteristics

16.1 Program & Erase Specifications

Typical values measured at $T_A = +25\text{ }^\circ\text{C}$ and nominal voltages

Table 25: Program-Erase Characteristics

Nbr.	Symbol	Parameter	Typ	Max ⁽⁸⁾	Unit	Notes
Conventional Word Programming						
W200	$t_{\text{PROG/W}}$	Single word Main Array	150	456	μs	
Buffered Programming						
W250	$t_{\text{PROG/B}}$	Aligned 32-Word BP Time (64 bytes)	176	716	μs	
		Aligned 64-Word BP Time (128 bytes)	216	900		
		Aligned 128-Word BP Time (256 bytes)	272	1140		1
		Aligned 256-Word BP Time	396	1690		1
		One Full Buffer(512-Word)	700	3016		
Erasing and Suspending						
W501	$t_{\text{ERS/MB}}$	Erase time for 64-KW Main Array Block	0.8	4	s	
W602	$t_{\text{ERS/SUSP}}$	Erase or Erase-Resume command to Erase-suspend command	—	500	μs	
W600	$t_{\text{SUSP/P}}$	Program suspend time	20	25	μs	
W601	$t_{\text{SUSP/E}}$	Erase suspend time	20	25		

Notes:

1. Does not apply when in Byte Mode (Byte# at VIL)

17.0 Ordering Information

Figure 17: Part Number Decoder

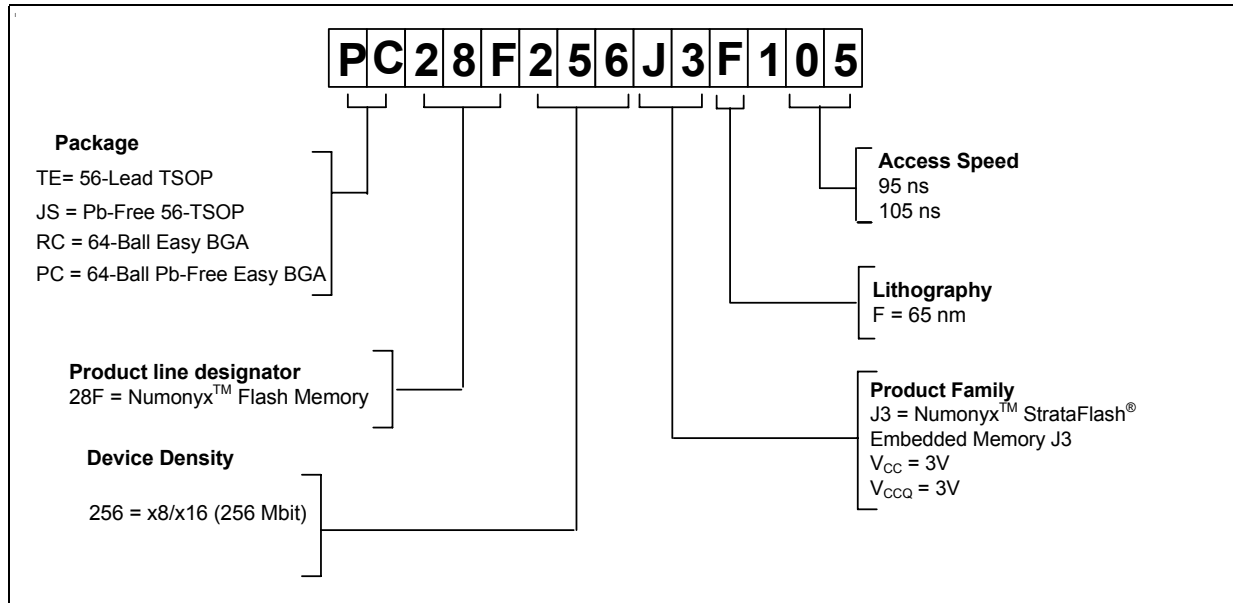

Table 26: Valid Combinations

256-Mbit
TE28F256J3F105
JS28F256J3F105
PC28F256J3F95
RC28F256J3F95

Appendix A Reference Information

A.1 Common Flash Interface

The CFI specification outlines device and host system software interrogation handshake which allows specific vendor-specified software algorithms to be used for entire families of devices. This allows device independent, JEDEC ID-independent, and forward- and backward-compatible software support for the specified flash device families. It allows flash vendors to standardize their existing interfaces for long-term compatibility.

This section defines the data structure or “database” returned by the CFI Query command. System software should parse this structure to gain critical information such as block size, density, x8/x16, and electrical specifications. Once this information has been obtained, the software will know which command sets to use to enable flash writes, block erases, and otherwise control the flash component. The Query is part of an overall specification for multiple command set and control interface descriptions called CFI.

A.2 Query Structure Output

The Query “database” allows system software to gain information for controlling the flash component. This section describes the device’s CFI-compliant interface that allows the host system to access Query data.

Query data are always presented on the lowest-order data outputs (D[7:0]) only. The numerical offset value is the address relative to the maximum bus width supported by the device. On this family of devices, the Query table device starting address is a 10h, which is a word address for x16 devices.

For a word-wide (x16) device, the first two bytes of the Query structure, “Q” and “R” in ASCII, appear on the low byte at word addresses 10h and 11h. This CFI-compliant device outputs 00h data on upper bytes. Thus, the device outputs ASCII “Q” in the low byte (D[7:0]) and 00h in the high byte (D[15:8]).

At Query addresses containing two or more bytes of information, the least significant data byte is presented at the lower address, and the most significant data byte is presented at the higher address.

In all of the following tables, addresses and data are represented in hexadecimal notation, so the “h” suffix has been dropped. In addition, since the upper byte of word-wide devices is always “00h,” the leading “00” has been dropped from the table notation and only the lower byte value is shown. Any x16 device outputs can be assumed to have 00h on the upper byte in this mode.

Table 27: Summary of Query Structure Output as a Function of Device and Mode

Device Type/ Mode	Query start location in maximum device bus width addresses	Query data with maximum device bus width addressing			Query data with byte addressing		
		Hex Offset	Hex Code	ASCII Value	Hex Offset	Hex Code	ASCII Value
x16 device x16 mode	10h	10:	0051	“Q”	20:	51	“Q”
		11:	0052	“R”	21:	00	“Null”
		12:	0059	“Y”	22:	52	“R”
x16 device					20:	51	“Q”

Table 27: Summary of Query Structure Output as a Function of Device and Mode

Device Type/ Mode	Query start location in maximum device bus width addresses	Query data with maximum device bus width addressing			Query data with byte addressing		
		Hex Offset	Hex Code	ASCII Value	Hex Offset	Hex Code	ASCII Value
x8 mode	N/A ⁽¹⁾		N/A ⁽¹⁾		21:	51	"Q"
					22:	52	"R"

Note:

1. The system must drive the lowest order addresses to access all the device's array data when the device is configured in x8 mode. Therefore, word addressing, where these lower addresses are not toggled by the system, is "Not Applicable" for x8-configured devices.

Table 28: Example of Query Structure Output of a x16- and x8-Capable Device

Word Addressing			Byte Addressing		
Offset	Hex Code	Value	Offset	Hex Code	Value
A ₁₅ -A ₀	D ₁₅ -D ₀		A ₇ -A ₀	D ₇ -D ₀	
0010h	0051	"Q"	20h	51	"Q"
0011h	0052	"R"	21h	51	"Q"
0012h	0059	"Y"	22h	52	"R"
0013h	P_ID _{LO}	PrVendor	23h	52	"R"
0014h	P_ID _{HI}	ID #	24h	59	"Y"
0015h	P _{LO}	PrVendor	25h	59	"Y"
0016h	P _{HI}	TblAdr	26h	P_ID _{LO}	PrVendor
0017h	A_ID _{LO}	AltVendor	27h	P_ID _{LO}	PrVendor
0018h	A_ID _{HI}	ID #	28h	P_ID _{HI}	ID #
...

A.2.1 Query Structure Overview

The Query command causes the flash component to display the Common Flash Interface (CFI) Query structure or "database." The structure sub-sections and address locations are summarized below. See *AP-646 Common Flash Interface (CFI) and Command Sets* (order number 292204) for a full description of CFI.

The following sections describe the Query structure sub-sections in detail.

Table 29: Query Structure

Offset	Sub-Section Name	Description	Notes
00h		Manufacturer Code	1
01h		Device Code	1
(BA+2)h ⁽²⁾	Block Status Register	Block-Specific Information	1,2
04-0Fh	Reserved	Reserved for Vendor-Specific Information	1
10h	CFI Query Identification String	Reserved for Vendor-Specific Information	1
1Bh	System Interface Information	Command Set ID and Vendor Data Offset	1

Table 29: Query Structure

Offset	Sub-Section Name	Description	Notes
27h	Device Geometry Definition	Flash Device Layout	1
p ⁽³⁾	Primary Numonyx-Specific Extended Query Table	Vendor-Defined Additional Information Specific to the Primary Vendor Algorithm	1,3

Notes:

1. Refer to the Query Structure Output section and offset 28h for the detailed definition of offset address as a function of device bus width and mode.
2. BA = Block Address beginning location (i.e., 02000h is block 2's beginning location when the block size is 128 Kbyte).
3. Offset 15 defines "P" which points to the *Primary Numonyx-Specific Extended Query Table*.

A.2.2 Block Status Register

The Block Status Register indicates whether an erase operation completed successfully or whether a given block is locked or can be accessed for flash program/erase operations.

Table 30: Block Status Register

Offset	Length	Description	Address	Value
(BA+2)h ⁽¹⁾	1	Block Lock Status Register	BA+2:	--00 or --01
		BSR.0 Block Lock Status 0 = Unlocked 1 = Locked	BA+2:	(bit 0): 0 or 1
		BSR 2-7: <i>Reserved for Future Use</i>	BA+2:	(bit 2-7): 0

Note:

1. BA = The beginning location of a Block Address (i.e., 008000h is block 1's (64-KB block) beginning location in word mode).

A.2.3 CFI Query Identification String

The CFI Query Identification String provides verification that the component supports the Common Flash Interface specification. It also indicates the specification version and supported vendor-specified command set(s).

Table 31: CFI Identification

Offset	Length	Description	Add.	Hex Code	Value
10h	3	Query-unique ASCII string "QRY"	10:	--51	"Q"
			11:	--52	"R"
			12:	--59	"Y"
13h	2	Primary vendor command set and control interface ID code. 16-bit ID code for vendor-specified algorithms	13:	--01	
			14:	--00	
15h	2	Extended Query Table primary algorithm address	15:	--31	
			16:	--00	
17h	2	Alternate vendor command set and control interface ID code. 0000h means no second vendor-specified algorithm exists	17:	--00	
			18:	--00	
19h	2	Secondary algorithm Extended Query Table address. 0000h means none exists	19:	--00	
			1A:	--00	

A.2.4 System Interface Information

The following device information can optimize system interface software.

Table 32: System Interface Information

Offset	Length	Description	Add.	Hex Code	Value
1Bh	1	V _{CC} logic supply minimum program/erase voltage bits 0–3 BCD 100 mV bits 4–7 BCD volts	1B:	--27	2.7 V
1Ch	1	V _{CC} logic supply maximum program/erase voltage bits 0–3 BCD 100 mV bits 4–7 BCD volts	1C:	--36	3.6 V
1Dh	1	V _{PEN} [programming] supply minimum program/erase voltage bits 0–3 BCD 100 mV bits 4–7 HEX volts	1D:	--00	0.0 V
1Eh	1	V _{PEN} [programming] supply maximum program/erase voltage bits 0–3 BCD 100 mV bits 4–7 HEX volts	1E:	--00	0.0 V
1Fh	1	"n" such that typical single word program time-out = 2 ⁿ μs	1F:	--08	256 μs
20h	1	"n" such that typical max. buffer write time-out = 2 ⁿ μs	20:	--0A	1024 μs
21h	1	"n" such that typical block erase time-out = 2 ⁿ ms	21:	--0A	1 s
22h	1	"n" such that typical full chip erase time-out = 2 ⁿ ms	22:	--00	NA
23h	1	"n" such that maximum word program time-out = 2 ⁿ times typical	23:	--01	512 μs
24h	1	"n" such that maximum buffer write time-out = 2 ⁿ times typical	24:	--02	4096 μs
25h	1	"n" such that maximum block erase time-out = 2 ⁿ times typical	25:	--02	4 s
26h	1	"n" such that maximum chip erase time-out = 2 ⁿ times typical	26:	--00	NA

A.2.5 Device Geometry Definition

This field provides critical details of the flash device geometry.

Table 33: Device Geometry Definition

Offset	Length	Description	Code See Table Below		
27h	1	"n" such that device size = 2 ⁿ in number of bytes	27:		
28h	2	Flash device interface: <u>x8 async</u> <u>x16 async</u> <u>x8/x16 async</u> 28:00,29:00 28:01,29:00 28:02,29:00	28:	--02	x8/ x16
			29:	--00	
2Ah	2	"n" such that maximum number of bytes in write buffer = 2 ⁿ	2A:	--0A	1024 bytes
			2B:	--00	
2Ch	1	Number of erase block regions within device: 1. x = 0 means no erase blocking; the device erases in "bulk" 2. x specifies the number of device or partition regions with one or more contiguous same-size erase blocks 3. Symmetrically blocked partitions have one blocking region 4. Partition size = (total blocks) x (individual block size)	2C:	--01	1
2Dh	4	Erase Block Region 1 Information bits 0–15 = y, y+1 = number of identical-size erase blocks bits 16–31 = z, region erase block(s) size are z x 256 bytes	2D:		
			2E:		
			2F:		
			30:		

Table 34: Device Geometry: Address Codes

Address	256 Mbit
27:	--19
28:	--02
29:	--00
2A:	--05
2B:	--00
2C:	--01
2D:	--FF
2E:	--00
2F:	--00
30:	--02

A.2.6 Primary-Vendor Specific Extended Query Table

Certain flash features and commands are optional. The *Primary Vendor-Specific Extended Query* table specifies this and other similar information.

Table 35: Primary Vendor-Specific Extended Query (Sheet 1 of 2)

Offset ⁽¹⁾ P = 31h	Length	Description (Optional Flash Features and Commands)	Add.	Hex Code	Value
(P+0)h	3	Primary extended query table	31:	--50	"P"
(P+1)h		Unique ASCII string "PRI"	32:	--52	"R"
(P+2)h			33:	--49	"I"
(P+3)h	1	Major version number, ASCII	34:	--31	"1"
(P+4)h	1	Minor version number, ASCII	35:	--31	"1"
(P+5)h (P+6)h (P+7)h (P+8)h	4	Optional feature and command support (1=yes, 0=no) Undefined bits are "0." If bit 31 is "1" then another 31 bit field of optional features follows at the end of the bit-30 field.	36:	--CE	
		bit 0 Chip erase supported	37:	--00	
		bit 1 Suspend erase supported	38:	--00	
		bit 2 Suspend program supported	39:	--00	
		bit 3 Legacy lock/unlock supported	bit 0 = 0	No	
		bit 4 Queued erase supported	bit 1 = 1	Yes	
		bit 5 Instant Individual block locking supported	bit 2 = 1	Yes	
		bit 6 Protection bits supported	bit 3 = 1 ⁽¹⁾	Yes ⁽¹⁾	
		bit 7 Page-mode read supported	bit 4 = 0	No	
		bit 8 Synchronous read supported	bit 5 = 0	No	
	bit 6 = 1	Yes			
	bit 7 = 1	Yes			
	bit 8 = 0	No			
	bit 9 = 0	No			
	bit 30 CFI Link(s) to follow (256 Mb)	bit 30 = 0	No		
	bit 31 Another "Optional Feature" field to follow	bit 31 = 0	No		

Table 35: Primary Vendor-Specific Extended Query (Sheet 2 of 2)

Offset ⁽¹⁾ P = 31h	Length	Description (Optional Flash Features and Commands)	Add.	Hex Code	Value
(P+9)h	1	Supported functions after suspend: read Array, Status, Query Other supported operations are: bits 1–7 reserved; undefined bits are "0" bit 0 Program supported after erase suspend	3A:	--01	
			bit 0 = 1		Yes
(P+A)h (P+B)h	2	Block Status Register mask bits 2–15 are Reserved; undefined bits are "0" bit 0 Block Lock-Bit Status register active bit 1 Block Lock-Down Bit Status active	3B: 3C:	--01 --00	
			bit 0 = 1		Yes
			bit 1 = 0		No
(P+C)h	1	V _{CC} logic supply highest performance program/erase voltage bits 0–3 BCD value in 100 mV bits 4–7 BCD value in volts	3D:	--33	3.3 V
(P+D)h	1	V _{PEN} optimum program/erase supply voltage bits 0–3 BCD value in 100 mV bits 4–7 HEX value in volts	3E:	--00	0.0 V

Note:

- Future devices may not support the described "Legacy Lock/Unlock" function. Thus bit 3 would have a value of "0."
- Setting this bit, will lead to the extension of the CFI table.

Table 36: Protection Register Information

Offset ⁽¹⁾ P = 31h	Length	Description (Optional Flash Features and Commands)	Add.	Hex Code	Value
(P+E)h	1	Number of Protection register fields in JEDEC ID space. "00h," indicates that 256 protection bytes are available	3F:	--01	01
(P+F)h (P+10)h (P+11)h (P+12)h	4	Protection Field 1: Protection Description This field describes user-available One Time Programmable (OTP) protection register bytes. Some are pre-programmed with device-unique serial numbers. Others are user-programmable. Bits 0-15 point to the protection register lock byte, the section's first byte. The following bytes are factory pre-programmed and user-programmable. bits 0-7 = Lock/bytes JEDEC-plane physical low address bits 8-15 = Lock/bytes JEDEC-plane physical high address bits 16-23 = "n" such that 2 ⁿ = factory pre-programmed bytes bits 24-31 = "n" such that 2 ⁿ = user-programmable bytes	40: 41: 42: 43:	--80 --00 --03 --03	80h 00h 8bytes 8bytes

Note:

- The variable P is a pointer which is defined at CFI offset 15h.

Table 37: Burst Read Information

Offset ⁽¹⁾ P = 31h	Length	Description (Optional Flash Features and Commands)	Add.	Hex Code	Value
(P+13)h	1	Page Mode Read capability bits 0-7 = "n" such that 2 ⁿ HEX value represents the number of read-page bytes. See offset 28h for device word width to determine page-mode data output width. 00h indicates no read page buffer.	44:	--05	32 bytes
(P+14)h	1	Number of synchronous mode read configuration fields that follow. 00h indicates no burst capability.	45:	--00	0
(P+15)h	1	Synchronous Mode Read Capability Configuration 1 Bits 3-7 = Reserved bits 0-2 = "n" such that 2 ⁿ⁺¹ HEX value represents the maximum number of continuous synchronous burst reads when the device is configured for its maximum word width. A value of 07h indicates that the device is capable of continuous linear bursts until that will output data until the internal burst counter reaches the end of the device's burstable address space. This field's 3-bit value can be written directly to the Read Configuration Register Bits 0-2 if the device is configured for its maximum word width. See offset 1Fh for word width to determine the burst data output width.	46:	--00	n/a
(P+16)h	1	Synchronous Mode Read Capability Configuration 2	47:	--00	n/a
(P+45)h	1	J3C mark for VIL fix for customers	76:	--01	01

Note:

- The variable P is a pointer which is defined at CFI offset 15h.

A.3 Flow Charts

Figure 18: Program/Erase Suspend/Resume Flowchart

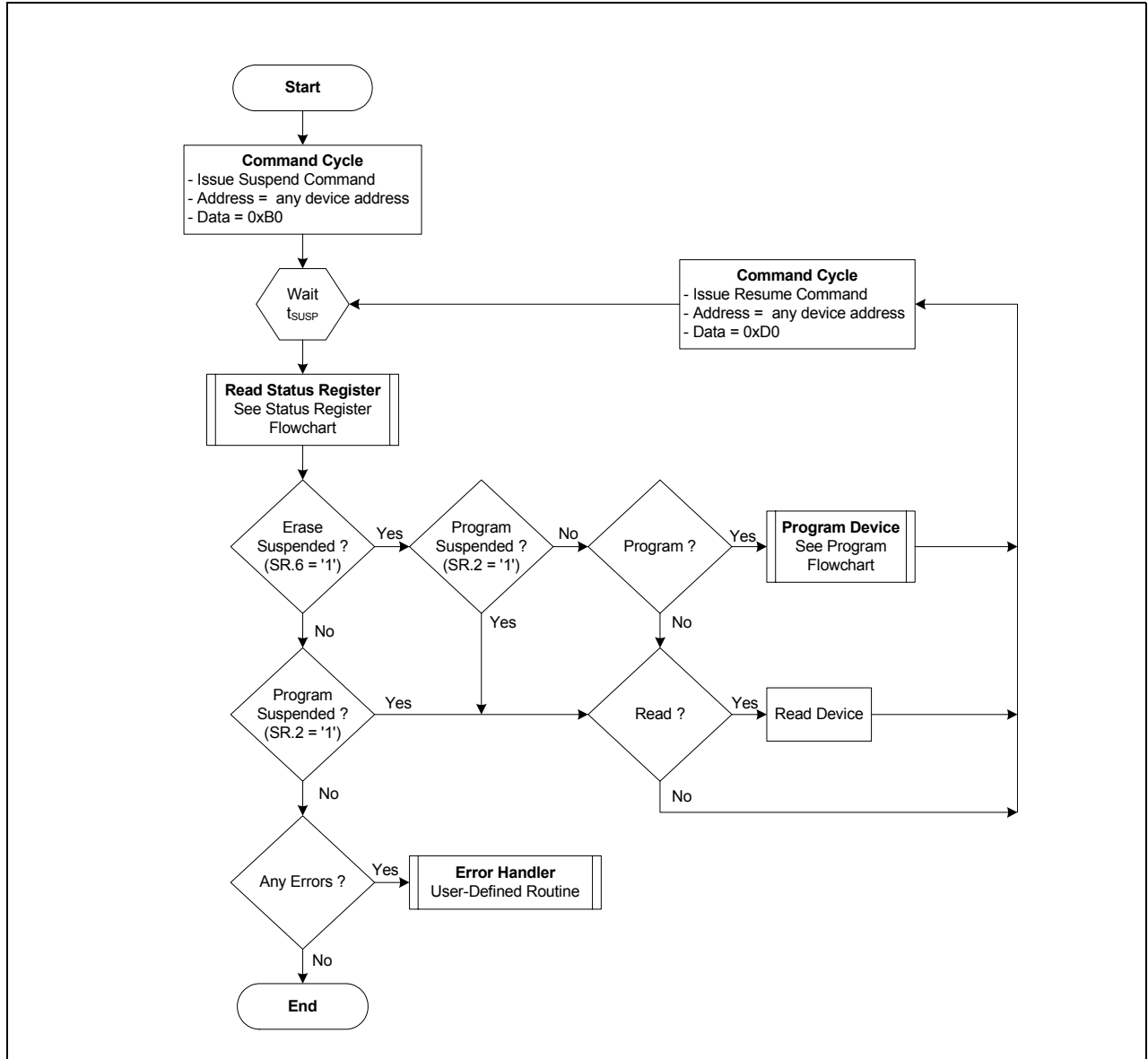
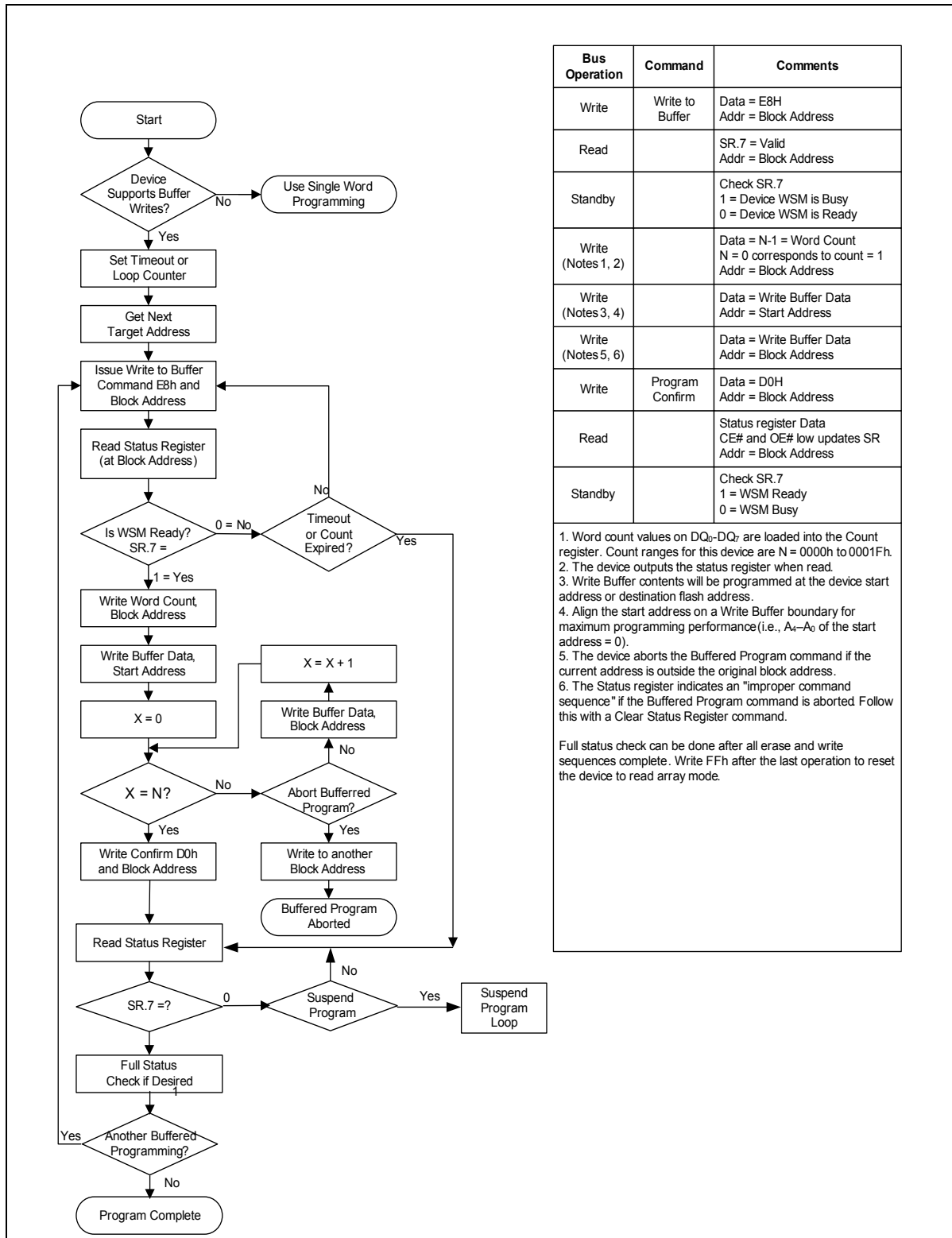

Figure 19: Buffer Program Flowchart



Bus Operation	Command	Comments
Write	Write to Buffer	Data = E8H Addr = Block Address
Read		SR.7 = Valid Addr = Block Address
Standby		Check SR.7 1 = Device WSM is Busy 0 = Device WSM is Ready
Write (Notes 1, 2)		Data = N-1 = Word Count N = 0 corresponds to count = 1 Addr = Block Address
Write (Notes 3, 4)		Data = Write Buffer Data Addr = Start Address
Write (Notes 5, 6)		Data = Write Buffer Data Addr = Block Address
Write	Program Confirm	Data = D0H Addr = Block Address
Read		Status register Data CE# and OE# low updates SR Addr = Block Address
Standby		Check SR.7 1 = WSM Ready 0 = WSM Busy

1. Word count values on DQ₆-DQ₇ are loaded into the Count register. Count ranges for this device are N = 0000h to 0001Fh.
 2. The device outputs the status register when read.
 3. Write Buffer contents will be programmed at the device start address or destination flash address.
 4. Align the start address on a Write Buffer boundary for maximum programming performance (i.e., A₄-A₀ of the start address = 0).
 5. The device aborts the Buffered Program command if the current address is outside the original block address.
 6. The Status register indicates an "improper command sequence" if the Buffered Program command is aborted. Follow this with a Clear Status Register command.

Full status check can be done after all erase and write sequences complete. Write FFh after the last operation to reset the device to read array mode.

Figure 20: Block Lock Operations Flowchart

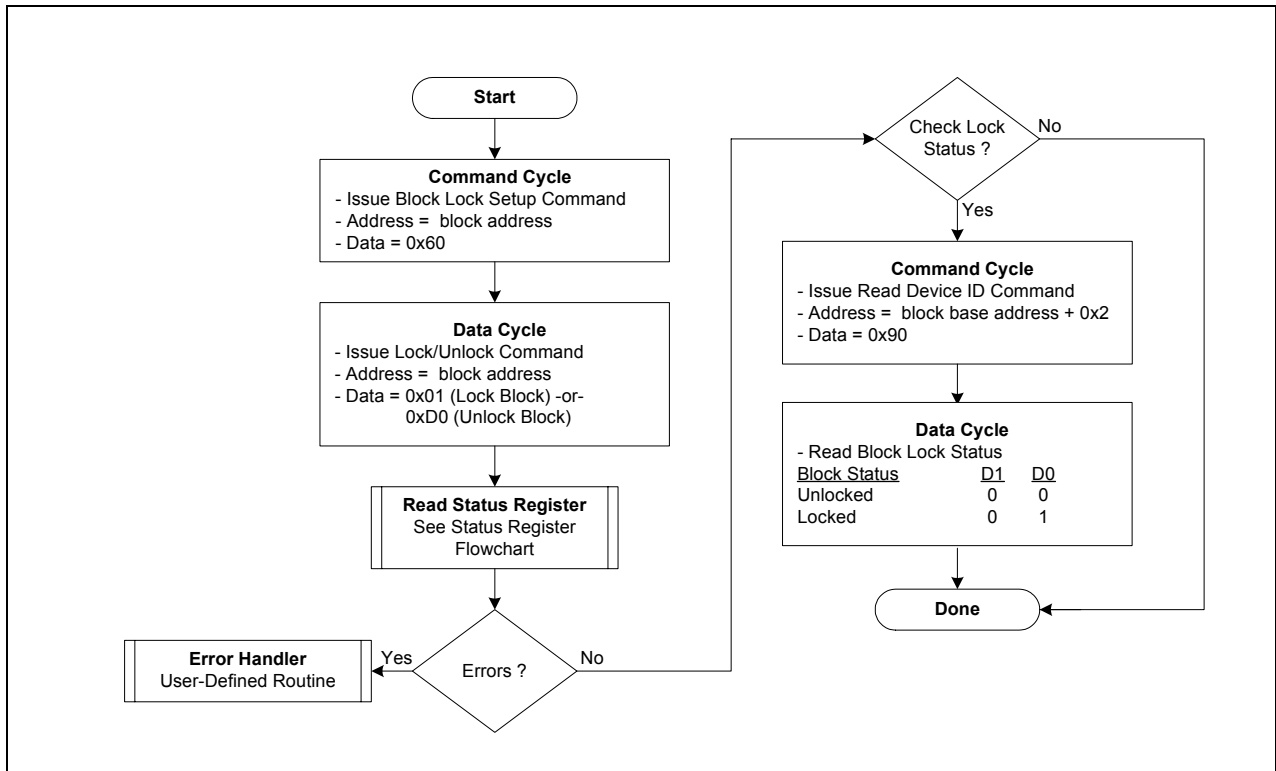

Figure 21: Block Erase Flowchart

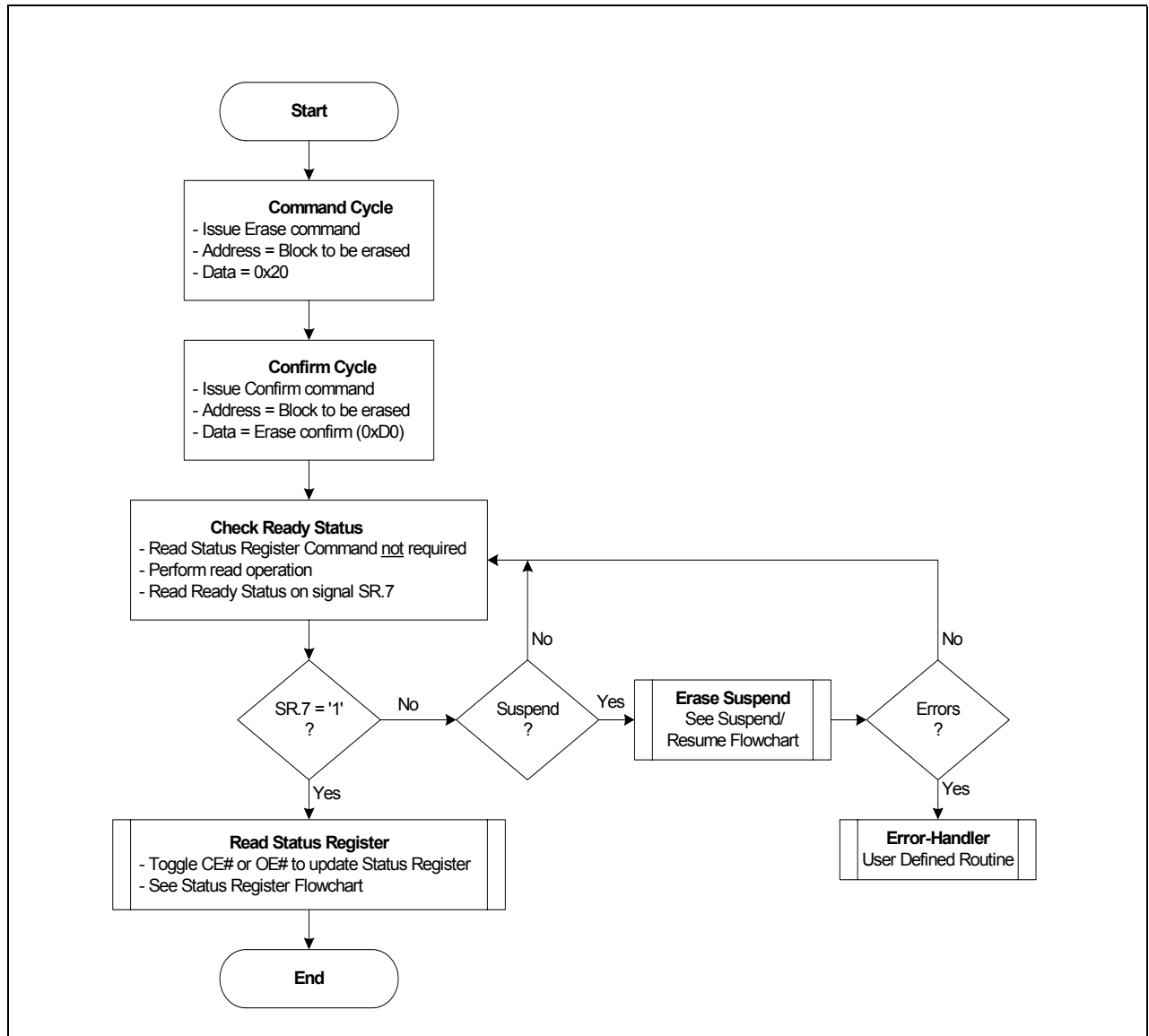

Figure 22: OTP Register Programming Flowchart

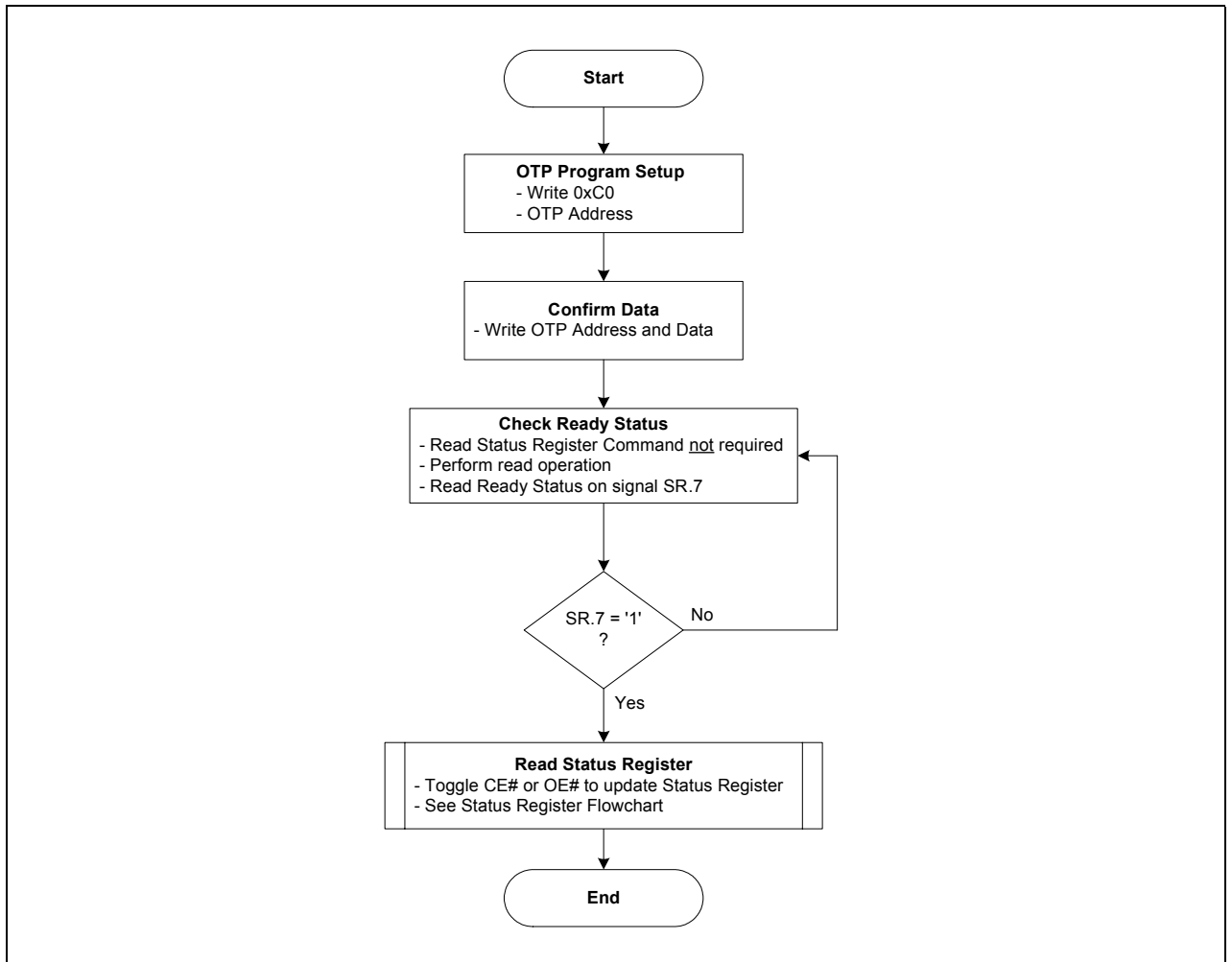
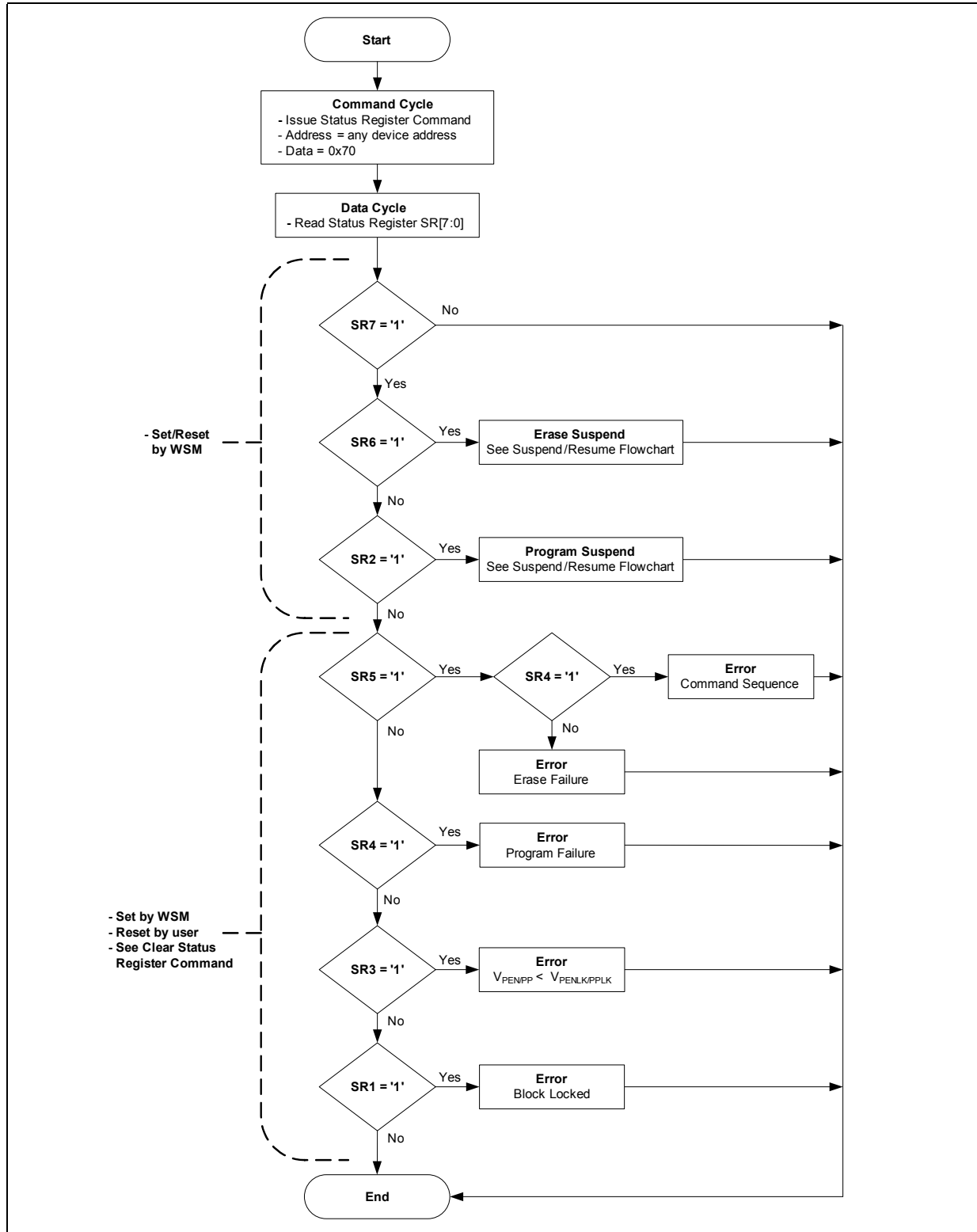

Figure 23: Status Register Flowchart



Appendix B Terms, definitions, and acronyms

B.1 Nomenclature

AMIN	All Densities	AMIN = A0 for x8
	All Densities	AMIN = A1 for x16
AMAX	256 Mbit	AMAX = A24
Block	A group of flash cells that share common erase circuitry and erase simultaneously.	
Clear	Indicates a logic zero (0)	
Program	Writes data to the flash array	
Set	Indicates a logic one (1)	
VPEN	Refers to a signal or package connection name	
V_{PEN}	Refers to timing or voltage levels	

B.2 Acronyms

CUI	Command User Interface
OTP	One Time Programmable
PLR	Protection Lock Register
PR	Protection Register
PRD	Protection Register Data
RFU	Reserved for Future Use
SR	Status Register
SRD	Status Register Data
WSM	Write State Machine
CFI	Common Flash Interface
FDI	Flash Data Integrator
MLC	Multi-Level Cell
SBC	Single Bit Cell
NC	Not Connect
DU	Don't Use

B.3 Conventions

h:	Hexadecimal Suffix
k (noun):	1,000
M (noun):	1,000,000
Bit:	1 bit
Nibble:	4 bits
Byte:	8 bits
Word:	16 bits
KByte:	1,024 bytes
Kword:	1,024 words
Kb:	1,024 bits
KB:	1,024 bytes
Mb:	1,048,576 bits
MB:	1,048,576 bytes
Brackets:	Square brackets ([]) will be used to designate group membership or to define a group of signals with similar function (i.e. A[21:1], SR[4,1] and D[15:0]).
00FFh:	Denotes 16-bit hexadecimal numbers
00FF 00FFh:	Denotes 32-bit hexadecimal numbers
DQ[15:0]:	Data I/O signals

Appendix C Revision History

Date	Revision	Description
May 2008	01	Initial release
December 2008	02	For 256-Mbit J3-65nm release