

THIS DRAWING IS UNPUBLISHED. RELEASED FOR PUBLICATION
 © COPYRIGHT - TE Connectivity ALL RIGHTS RESERVED.

REVISIONS				
P	LTR	DESCRIPTION	DATE	DWN APVD
E		ECO-17-012343	30NOV2017	LL SH

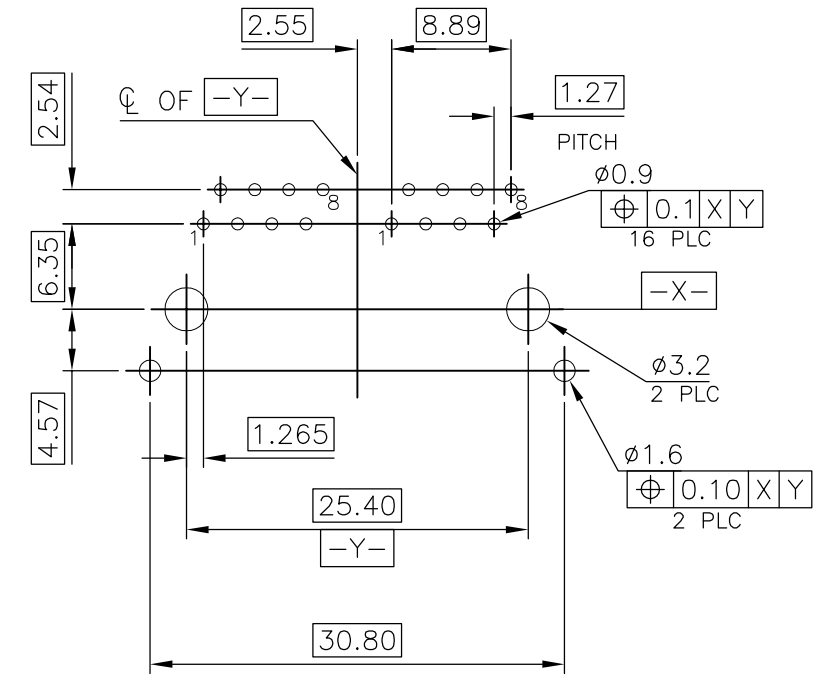

RECOMMENDED PCB LAYOUT (THICKNESS: 1.6mm)
 (DIMENSION TOLERANCE: 1 PLC: ±0.1 2PLC: ±0.05)
 TOP VIEW

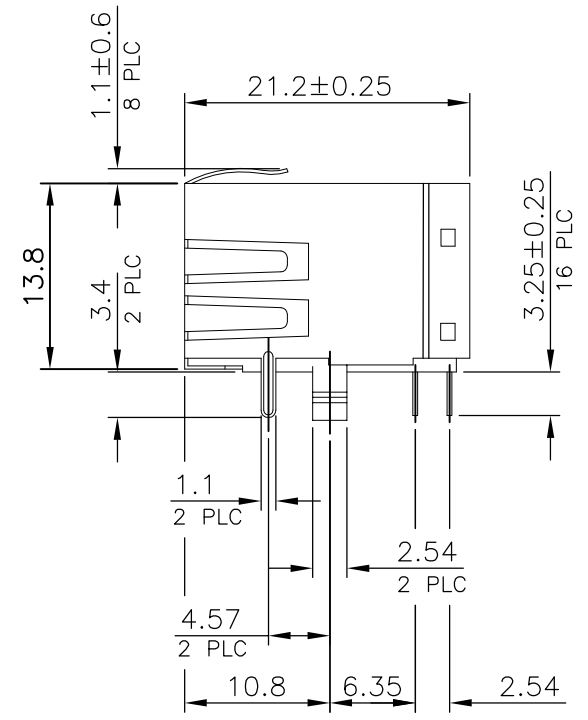
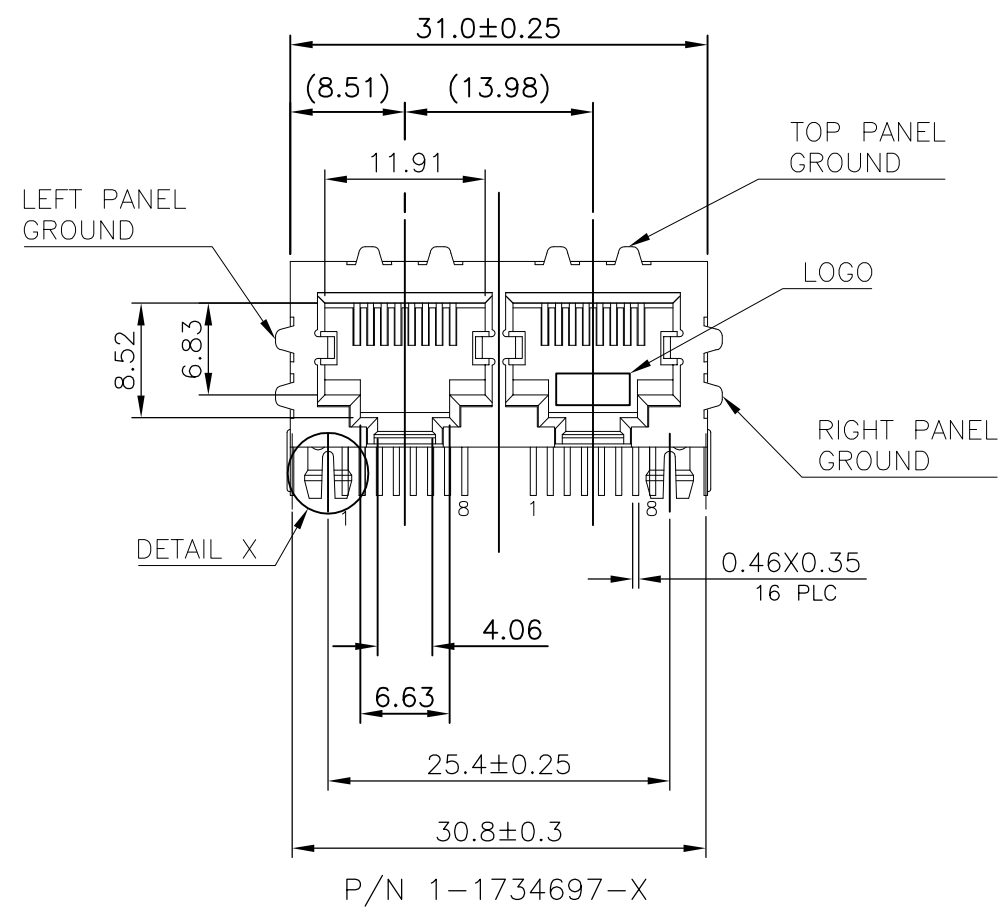
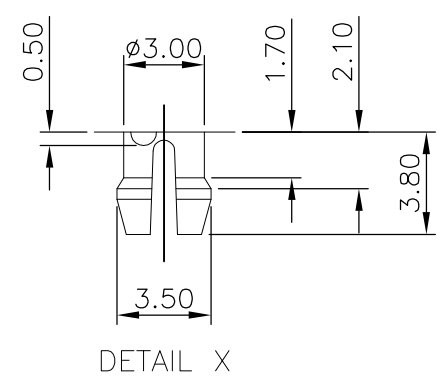
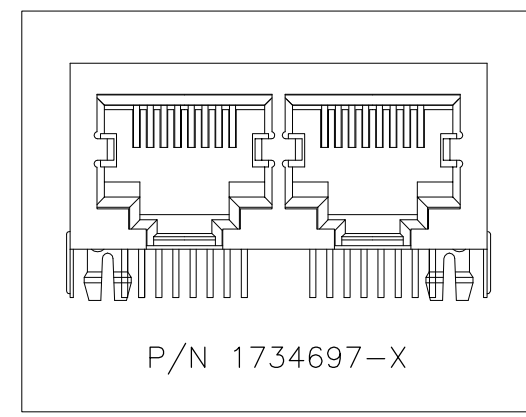
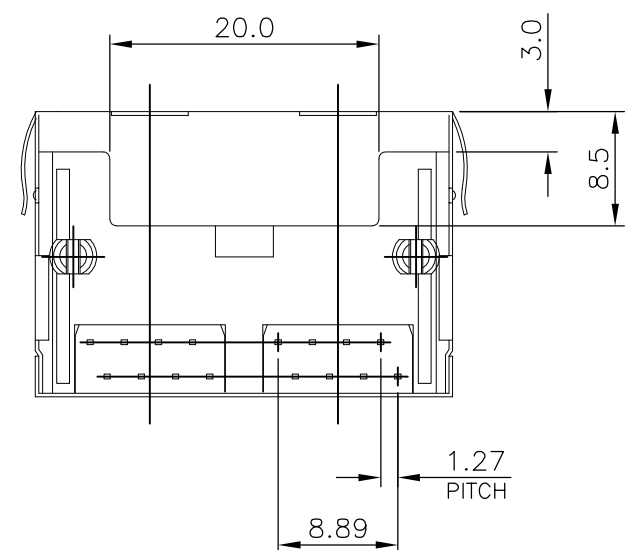

OBSOLETE	W	1.27um [50u"]	1-1734697-4
		0.762um [30u"]	1-1734697-3
		0.381um [15u"]	1-1734697-2
OBSOLETE	W/O	0.152um [6u"]	1-1734697-1
		1.27um [50u"]	1-1734697-4
		0.762um [30u"]	1-1734697-3
		0.381um [15u"]	1-1734697-2
		0.152um [6u"]	1-1734679-1
	PANEL GROUND	MIN. GOLD THICKNESS	PART NUMBER

NOTE:
 1. MATERIAL:
 HOUSING: PBT WITH 30% GF, UL94 V-0, COLOR: BLACK.
 CONTACTS: PHOSPHOR BRONZE.
 SHELL: BRASS.
 2. FINISH:
 CONTACTS: (SEE TABLE) GOLD PLATED ON CONTACT AREA, GOLD FLASH ON SOLDER TAIL, WITH ENTIRE CONTACT UNDERPLATED 1.27um [50u"] MIN. NICKEL.
 SHELL: 0.508um [20u"] MIN. NICKEL PLATED.
 3. WAVE SOLDER CAPABLE TO 240°C PER TE SPEC 109-202, CONDITION B.

THIS DRAWING IS A CONTROLLED DOCUMENT.		DWN T. KUO 09JUL2008		
		CHK A. WU 09JUL2008		
		APVD W. KODAMA 09JUL2008	NAME	
DIMENSIONS: mm		PRODUCT SPEC	MODULAR JACK CONNECTOR	
		APPLICATION SPEC	RJ45, 8P8C, TAB DOWN, 1X2 PORTS	
		108-57535	SHIELDED, DIP TYPE	
MATERIAL SEE NOTE		FINISH SEE NOTE	SIZE A3	CAGE CODE 00779
		WEIGHT 12	DRAWING NO. 1734697	RESTRICTED TO -
		CUSTOMER DRAWING	SCALE 1:1	SHEET 1 OF 2
				REV E

4

3

2

1

THIS DRAWING IS UNPUBLISHED. RELEASED FOR PUBLICATION
 © COPYRIGHT - TE Connectivity ALL RIGHTS RESERVED.

REVISIONS					
P	LTR	DESCRIPTION	DATE	DWN	APVD
-	-	SEE SHEET 1	-	-	-

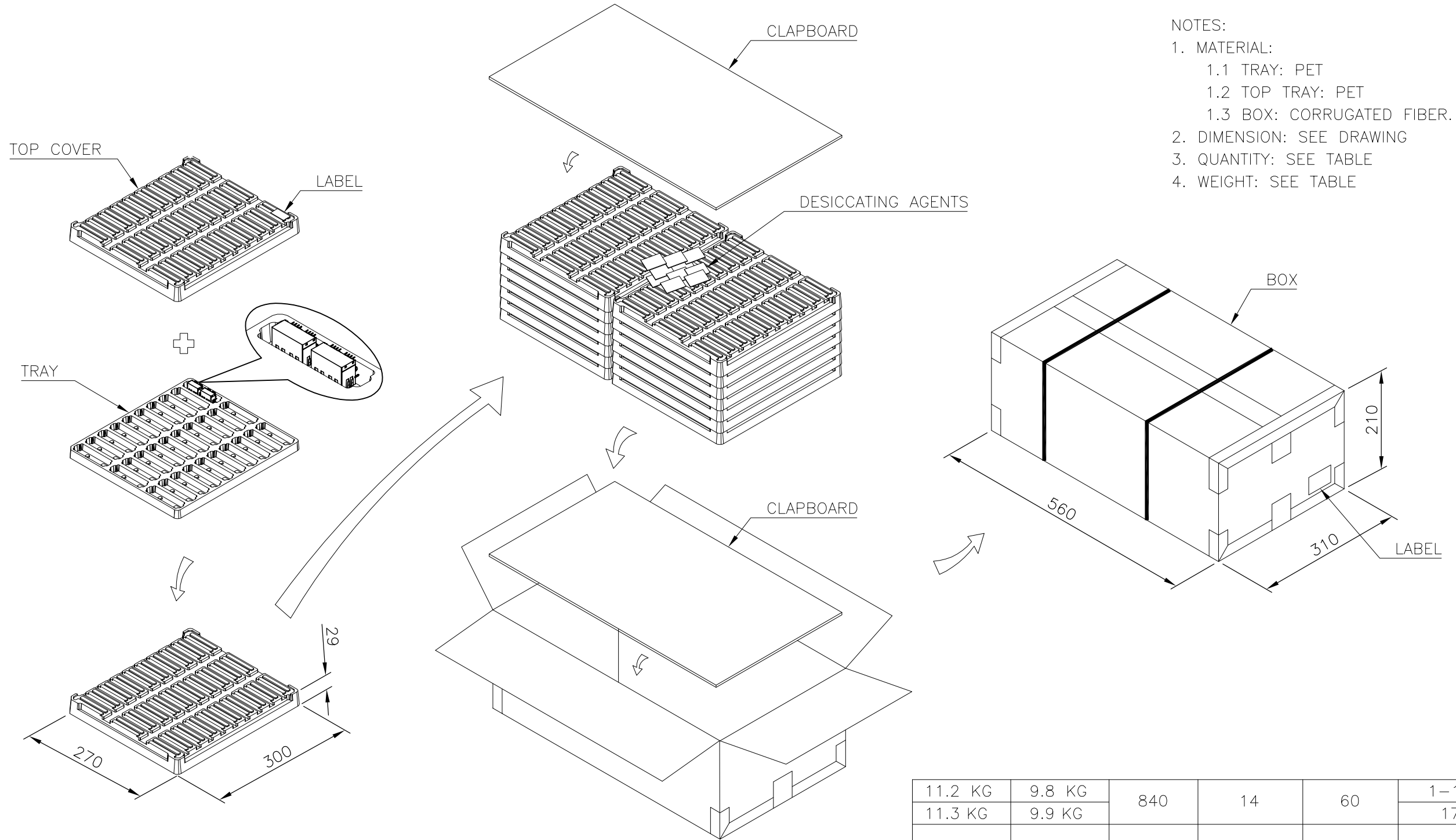

- NOTES:
- MATERIAL:
 - 1.1 TRAY: PET
 - 1.2 TOP TRAY: PET
 - 1.3 BOX: CORRUGATED FIBER.
 - DIMENSION: SEE DRAWING
 - QUANTITY: SEE TABLE
 - WEIGHT: SEE TABLE

11.2 KG	9.8 KG	840	14	60	1-1734697-X
11.3 KG	9.9 KG				1734697-X
WEIGHT (REF.)	WEIGHT (REF.)	PCS/BOX	TRAYS/BOX	PCS/TRAY	PART NUMBER

THIS DRAWING IS A CONTROLLED DOCUMENT.

DIMENSIONS: mm	TOLERANCES UNLESS OTHERWISE SPECIFIED:
	0 PLC ± -
	1 PLC ± 0.3
	2 PLC ± 0.2
	3 PLC ± 0.15
	4 PLC ± -
	ANGLES ± 3'
MATERIAL SEE NOTE	FINISH SEE NOTE

DWN T. KUO 09JUL2008	TE Connectivity NAME MODULAR JACK CONNECTOR RJ45,8P8C,TAB DOWN,1X2 PORTS SHIELDED, DIP TYPE			
CHK A. WU 09JUL2008				
APVD W. KODAMA 09JUL2008				
PRODUCT SPEC 108-57535				
APPLICATION SPEC -	SIZE A3	CAGE CODE 00779	DRAWING NO 1734697	RESTRICTED TO -
WEIGHT 12 GRAMS	SCALE 1:1	SHEET 2 OF 2	REV E	
CUSTOMER DRAWING				