

MATERIAL NUMBER	ENGINEERING NUMBER	STUD SIZE	"S"	PACKAGING
191930191	D-353-14	1/4	.265	(B) LOOSE PIECE
191930194	D-353-56	5/16	.328	
191930193	D-353-38	3/8	.390	
191930196	D-353-76	7/16	.453	
191930190	D-353-12	1/2	.515	
191930195	D-353-58	5/8	.656	
191930192	D-353-34	3/4	.781	

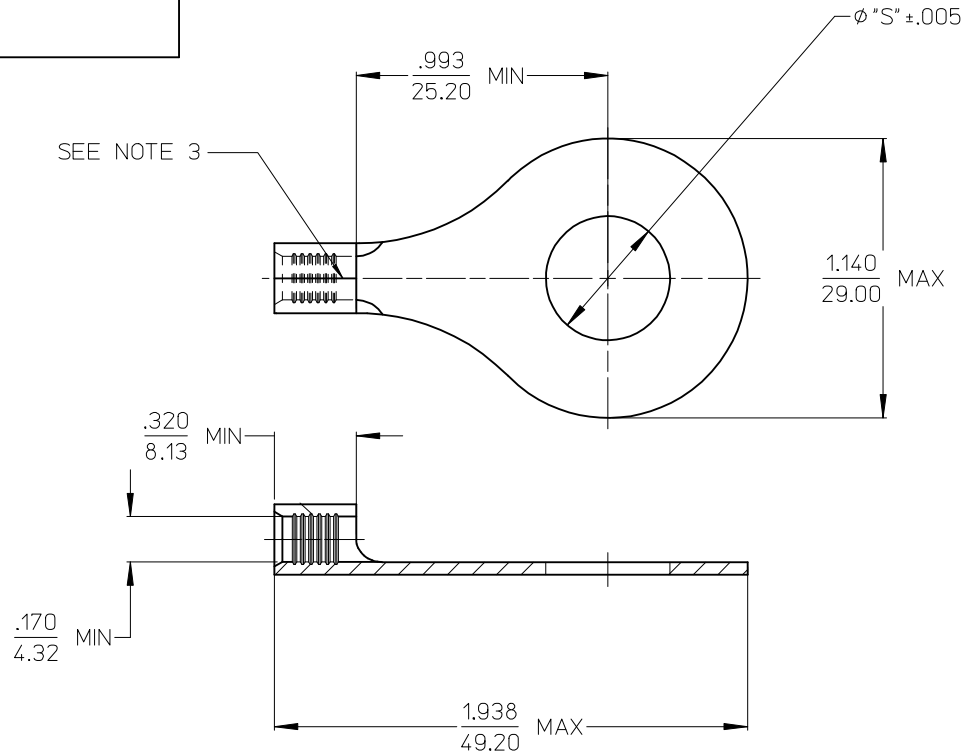

SALES DRAWING

- NOTES:
 1. MATERIAL: COPPER
 PLATING: ELECTROPLATE TIN
 2. ALL DIMENSIONS IN INCHES/(MM).
 3. BRAZED SEAM.
 4. PART IS ROHS COMPLIANT.

CORRECTED 1/4 STUD EC NO: IFC2015-1900 DRAWN: GROSASO1 2015/05/18 CHKD: JMACNEIL 2015/05/18 APPR: JMACNEIL 2015/05/28	QUALITY SYMBOLS ▽=0 ▽=0	GENERAL TOLERANCES (UNLESS SPECIFIED) mm INCH 4 PLACES ± --- ± --- 3 PLACES ± --- ± .005 2 PLACES ± 0.13 ± .01 1 PLACE ± 0.25 ± --- ANGULAR ± ---°	DIMENSION STYLE IN/MM DRAWN BY DATE ETHRODAHL 2008/02/21 CHECKED BY DATE JMACNEIL 2008/02/21 APPROVED BY DATE JMACNEIL 2008/02/21	SCALE 2:1 DESIGN UNITS INCH THIRD ANGLE PROJECTION	TITLE RING TONGUE TERMINAL 8 AWG VERSAKRIMP D-353 TONGUE
	DRAFT WHERE APPLICABLE MUST REMAIN WITHIN DIMENSIONS		MATERIAL NO. SEE CHART	DOCUMENT NO. SD-19193-037	SHEET NO. 1 OF 1
	THIS DRAWING CONTAINS INFORMATION THAT IS PROPRIETARY TO MOLEX INCORPORATED AND SHOULD NOT BE USED WITHOUT WRITTEN PERMISSION				
	MOLEX INCORPORATED				