

DASH NO.	FIG.	A $\begin{matrix} +.000 \\ -.020 \end{matrix}$	B	$\phi D$	
L6995-0	1	.122	.030	.072	
L6995-1		.167	.075		
L6995-2		.240	.148		
L6995-3		.117	.025		
L6995-4		.750	.658		
L6995-5		.340	.248		
L6995-6		.510	.418		
L6995-8		.140	.048		
L6995-9		.200	.108		
L6995-11		.350	.258		
L6995-12		.450	.358		
L6995-13		.310	.218		
L6995-14		.495	.403		
L6995-15		.555	.463		
L6995-16		2	.223		.155
L6995-18	1	.150	.058	.072	
L6995-21		.592	.500		
L6995-22		.217	.125		
L6995-23		.292	.200		
L6995-24		.270	.178		
L6995-25		.400	.308		
L6995-28		.237	.145		.045
L6995-29		.257	.165		
L6995-33		.097	.005	.072	

NOTE:  
1. APPLIES TO STANDARD  
JOHANSON MANUFACTURING  
PROCESSES

MI DRG. NO. L6995-#AA REV. AA  
**L6995 DASH NO.**

**TUNING ROTOR**

SPECIFICATIONS		FILE: AIROUT
THREADS	PRE-TORQUED & LUBRICATED	NOTE 1
FINISH	CHROMATE CONVERSION	
MOUNTING	JMC TAP P/N 7064 TAP DRILL #45 (.082)	
BRASS STRUCTURE		
APPLICATIONS: FOR HIGH Q VARIABLE REACTANCE TUNING OF MICROWAVE CAVITIES, FILTERS, AND OTHER RESONANT STRUCTURES.		

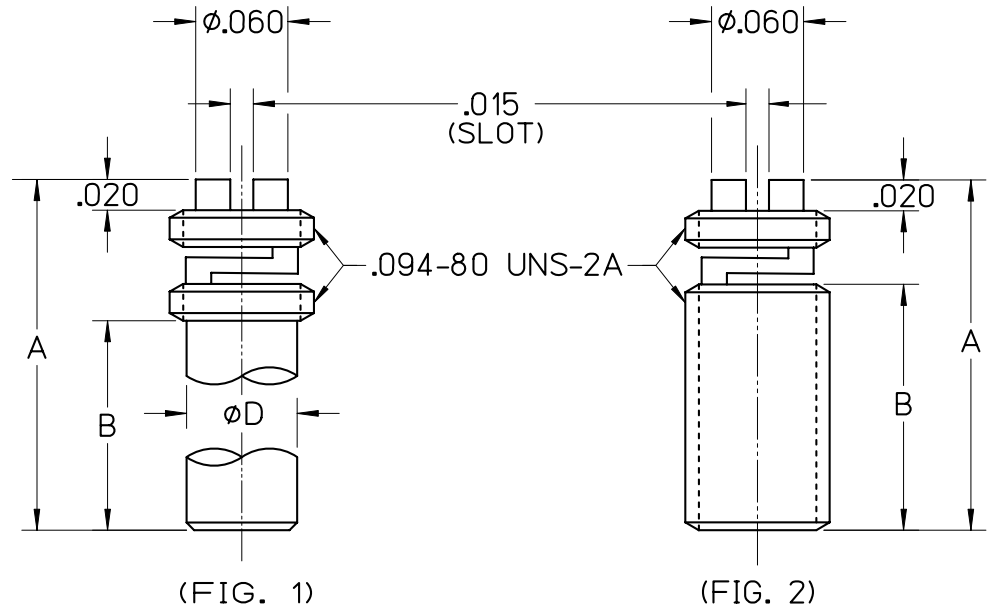

AA	10/24/16	MAI	MAI	MAI	001414
LEVEL	DATE	DRN.	CHK.	APP.	ECN
REVISIONS					
DRN.	MLD	CHK.	RJV	APP.	WEH
DATE	09/10/98	DATE	09/10/98	DATE	09/10/98
					SCALE 8" $\approx$ 1"
					.XX $\pm$ .015 .XXX $\pm$ .005



**JOHANSON MANUFACTURING CORPORATION**  
ROCKAWAY VALLEY ROAD, BOONTON, N.J. 07005 (973)334-2676 FAX (973)334-2954  
ELECTRONIC ACCURACY THROUGH MECHANICAL PRECISION