

DETAIL B

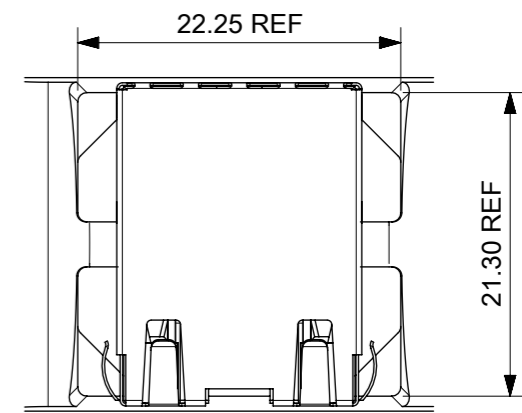

DETAIL C
SCALE 2:1

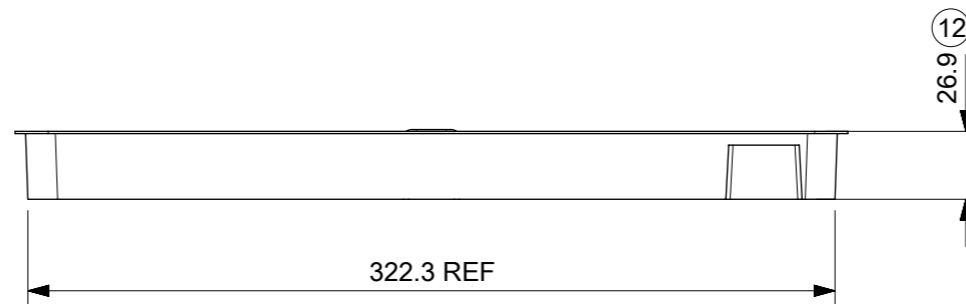
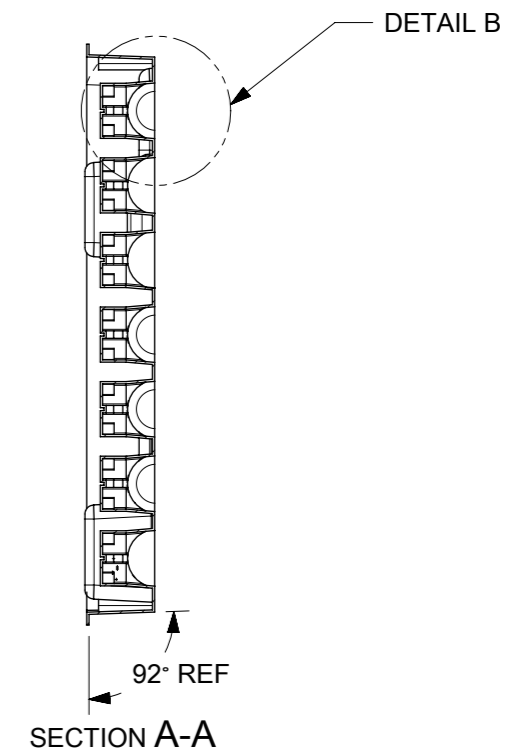
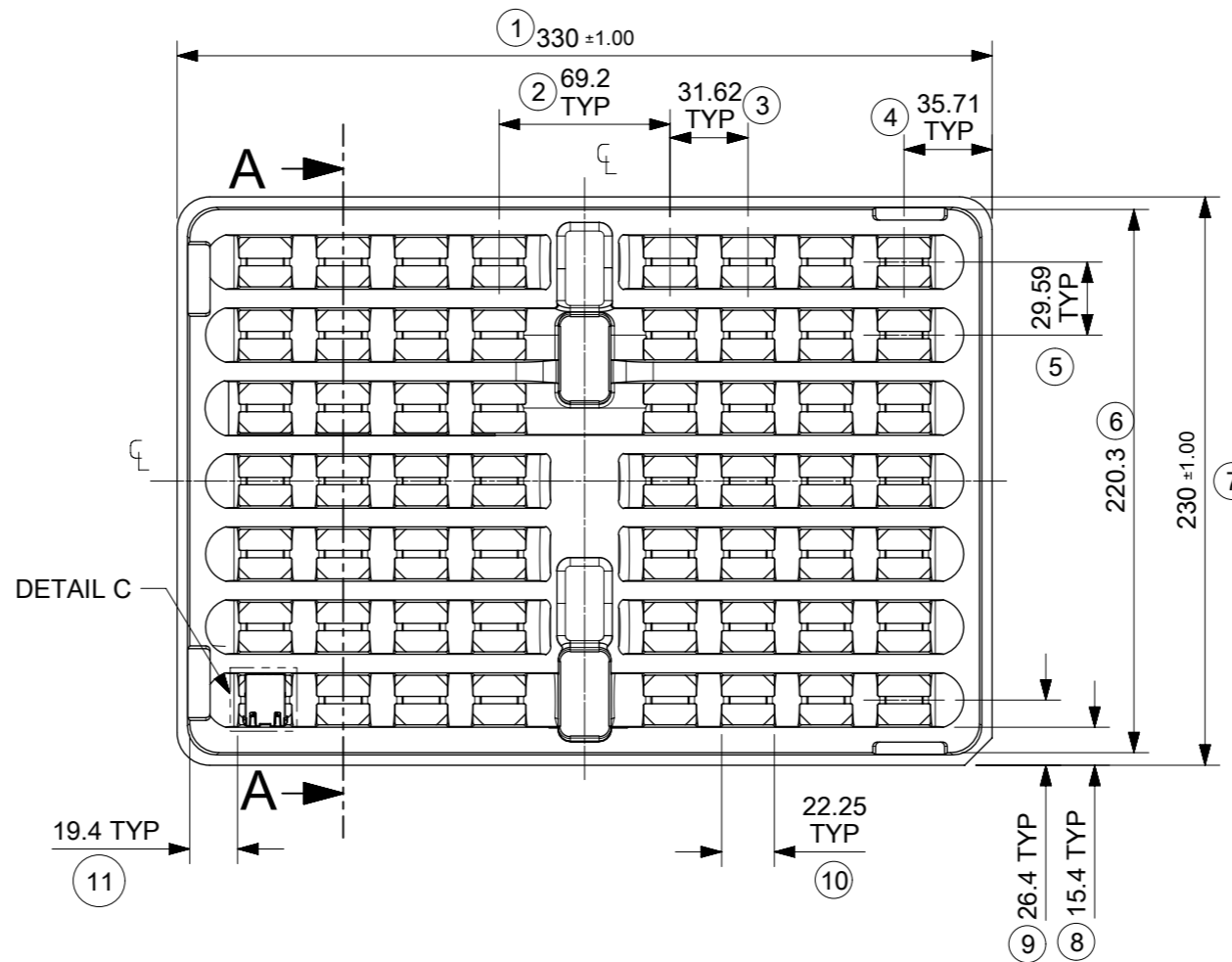

NOTES:

1. MATERIAL: PETA ANTISTATIC
2. THICKNESS: 0.9 mm ± 0.05 mm
3. COLOUR: CLEAR
4. BOW 2 mm MAXIMUM PER 330 mm
5. TWIST 2 mm MAXIMUM PER 330 mm
6. TRAY PART NO. AND RECYCLE LOGO TO BE CLEARLY MARKED ON TRAY
RECYCLE LOGO SHOULD BE APPROPRIATE TO MATERIAL USED
7. WHERE RELEVANT, DIMENSIONS SHOULD BE SYMMETRICAL ABOUT THE CENTRELINE
8. GENERAL PROFILE TOLERANCE $\overline{\cup}$ 0.40 ON NON DIMENSIONED FEATURES

LAST INSPECTION NUMBER USED: 12

THIS DRAWING CONTAINS INFORMATION THAT IS PROPRIETARY TO MOLEX ELECTRONIC TECHNOLOGIES, LLC AND SHOULD NOT BE USED WITHOUT WRITTEN PERMISSION									
DIMENSION UNITS		SCALE		CURRENT REV DESC: REMOVED REFERENCE TO QUANTITY OF TRAYS PER STACK				molex	
mm		1:3							
GENERAL TOLERANCES (UNLESS SPECIFIED)				EC NO: 602124				MXMAG STANDARD AND INVERTED TRAY	
ANGULAR TOL ± 1.0°				DRWN: DSHEA		2018/09/07			
4 PLACES ±				CHK'D: DBYRNES		2019/01/25			
3 PLACES ±				APPR: DBYRNES		2019/01/25			
2 PLACES ± 0.2				INITIAL REVISION:				PRODUCT CUSTOMER DRAWING	
1 PLACE ± 0.5				DRWN: KREILLY		2016/05/06		DOCUMENT NUMBER	
0 PLACES ±				APPR: STGRIFFIN		2016/12/07		934620003	
DRAFT WHERE APPLICABLE MUST REMAIN WITHIN DIMENSIONS		THIRD ANGLE PROJECTION		DRAWING		SERIES		MATERIAL NUMBER	
		A3-SIZE		93462		990250150		CUSTOMER	
						GENERAL MARKET		SHEET NUMBER	
								1 OF 1	

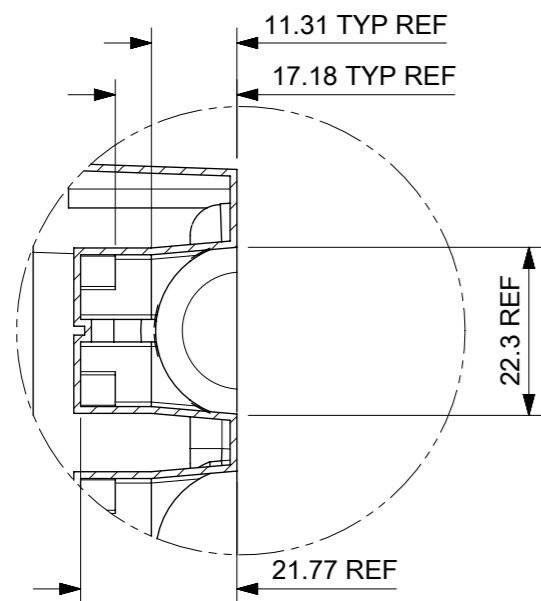

DETAIL B

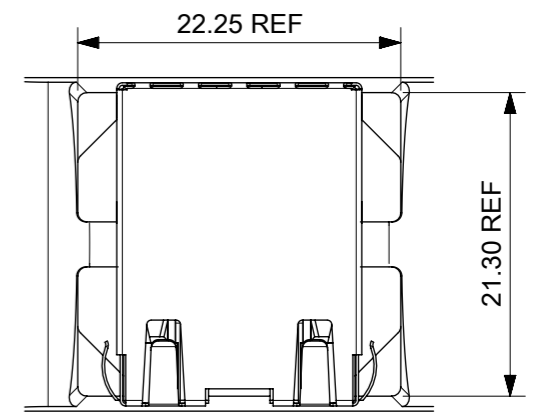
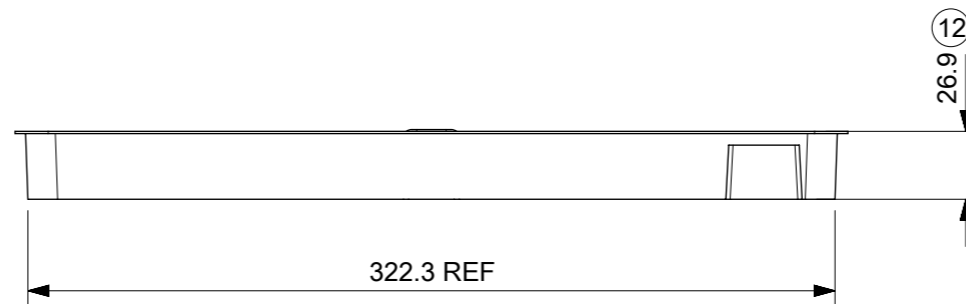

DETAIL C
SCALE 2:1

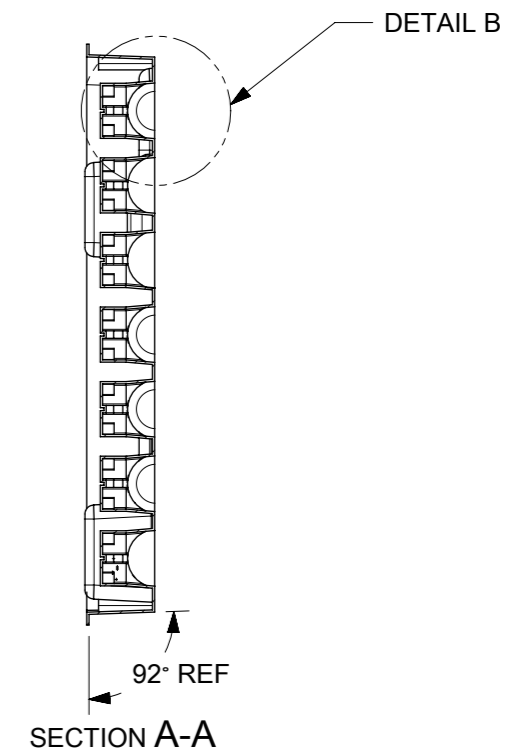
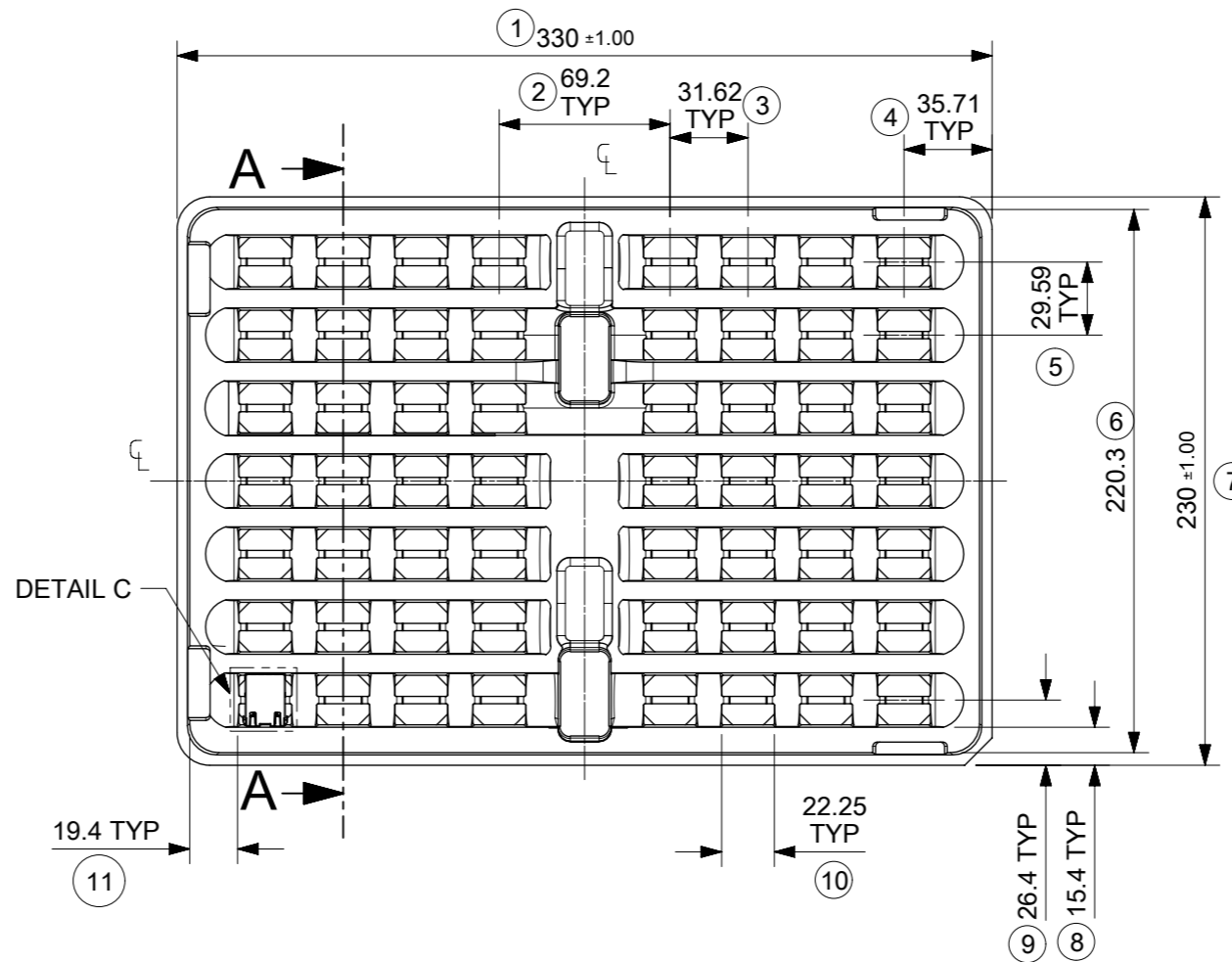

NOTES:

1. MATERIAL: PETA ANTISTATIC
2. THICKNESS: 0.9 mm ± 0.05 mm
3. COLOUR: CLEAR
4. BOW 2 mm MAXIMUM PER 330 mm
5. TWIST 2 mm MAXIMUM PER 330 mm
6. TRAY PART NO. AND RECYCLE LOGO TO BE CLEARLY MARKED ON TRAY
RECYCLE LOGO SHOULD BE APPROPRIATE TO MATERIAL USED
7. WHERE RELEVANT, DIMENSIONS SHOULD BE SYMMETRICAL ABOUT THE CENTRELINE
8. GENERAL PROFILE TOLERANCE $\overline{\cup}$ 0.40 ON NON DIMENSIONED FEATURES

LAST INSPECTION NUMBER USED: 12

THIS DRAWING CONTAINS INFORMATION THAT IS PROPRIETARY TO MOLEX ELECTRONIC TECHNOLOGIES, LLC AND SHOULD NOT BE USED WITHOUT WRITTEN PERMISSION									
DIMENSION UNITS		SCALE		CURRENT REV DESC: REMOVED REFERENCE TO QUANTITY OF TRAYS PER STACK				molex	
mm		1:3							
GENERAL TOLERANCES (UNLESS SPECIFIED)				EC NO: 602124				MXMAG STANDARD AND INVERTED TRAY	
ANGULAR TOL ± 1.0°				DRWN: DSHEA 2018/09/07					
4 PLACES ±				CHK'D: DBYRNES 2019/01/25					
3 PLACES ±				APPR: DBYRNES 2019/01/25					
2 PLACES ± 0.2				INITIAL REVISION:				PRODUCT CUSTOMER DRAWING	
1 PLACE ± 0.5				DRWN: KREILLY 2016/05/06				DOCUMENT NUMBER	
0 PLACES ±				APPR: STGRIFFIN 2016/12/07				934620003	
DRAFT WHERE APPLICABLE MUST REMAIN WITHIN DIMENSIONS		THIRD ANGLE PROJECTION		DRAWING		SERIES		MATERIAL NUMBER	
				A3-SIZE		93462		990250150	
				CUSTOMER		REVISION		SHEET NUMBER	
				GENERAL MARKET		B		1 OF 1	

INVERTED PROFILE MAGNETIC JACK
FAST ETHERNET, W/POE
& W/SHIELD TABS

- NOTES:
- SHIELD MATERIAL: 0.17mm THICK BRASS PRE-PLATED WITH NICKEL
SOLDER TABS POST DIPPED WITH MIN 1.27µm TIN.
 - HOUSING MATERIAL: LCP, BLACK, UL 94V-0
 - TERMINALS MATERIAL: PHOSPHOR BRONZE
RJ45 CONTACTS PLATING: BASE NICKEL PLATED WITH GOLD
FLASH OVER PALLADIUM NICKEL. REFER TO 938090001 PSP
PHY SOLDER TAILS: COPPER ALLOY
 - MATING INTERFACE ACCORDING TO IEC 60603-7 & TIA-1096-A
 - PRODUCT SPECIFICATION: 938090001 PSP
 - PACKAGING SPECIFICATION: 934620001 PSK - TRAY
 - STAND OFF TO SYSTEM BOARD 0.30mm MIN
 - RECOMMENDED PCB THICKNESS: 1.57mm
 - SHIELD: AVOID ROUTING TRACES OR PLACING ANY VIAS BELOW THESE AREAS
 - AREA FOR PICK AND PLACE: 5.0mmX 8.0mm
 - INSCRIPTION MARKED BY LASER:
1st : MOLEX
2nd : P/N (SEE BOM)
 - INSCRIPTION MARKED BY LASER:
DATE CODE (DAY/WEEK/YEAR)
 - MATERIAL COMPLIANT TO RoHS DIRECTIVE 2002/95/EC
 - PIN7 & PIN8 NOT ASSEMBLED

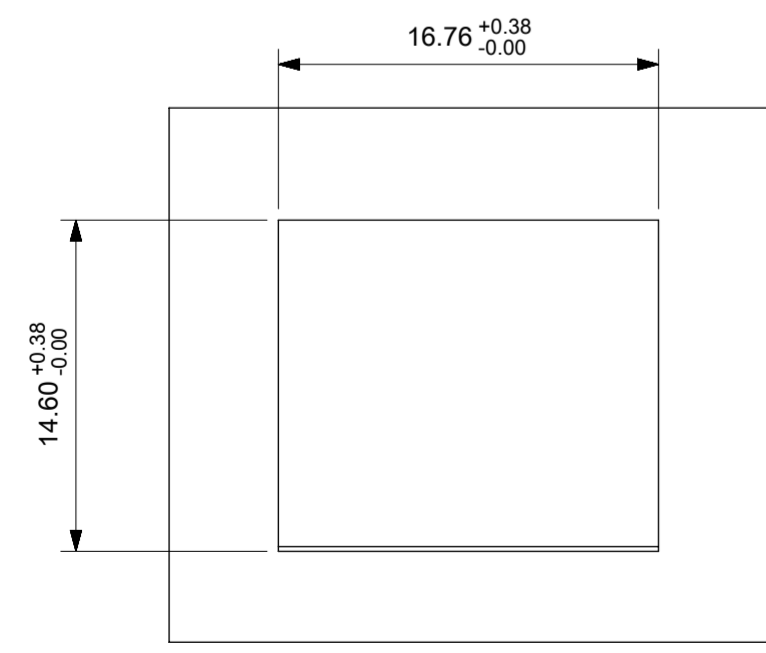
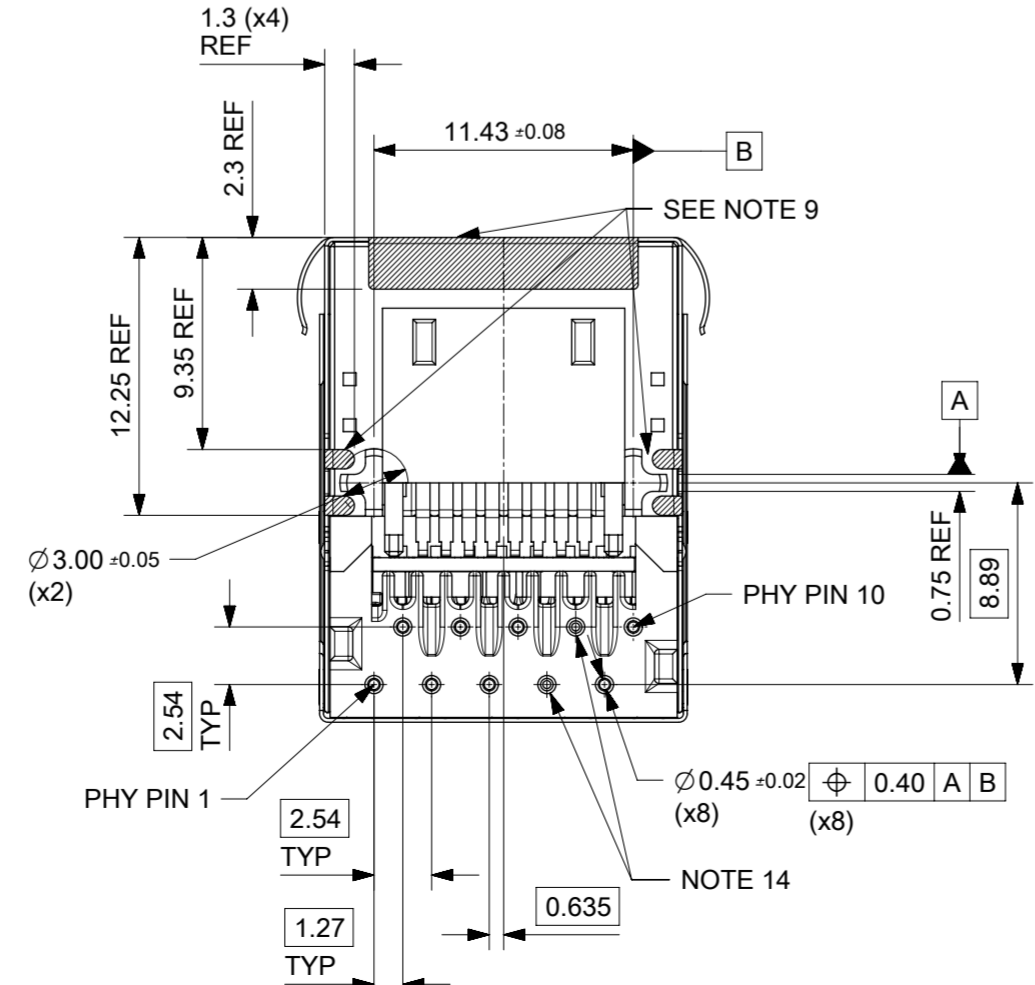
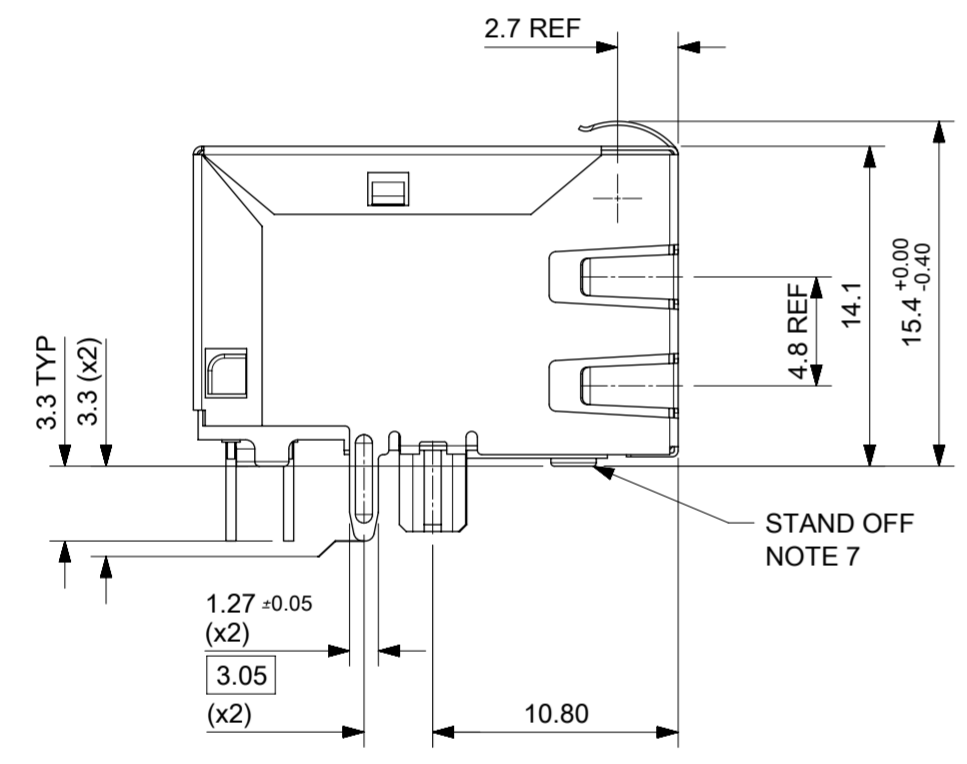
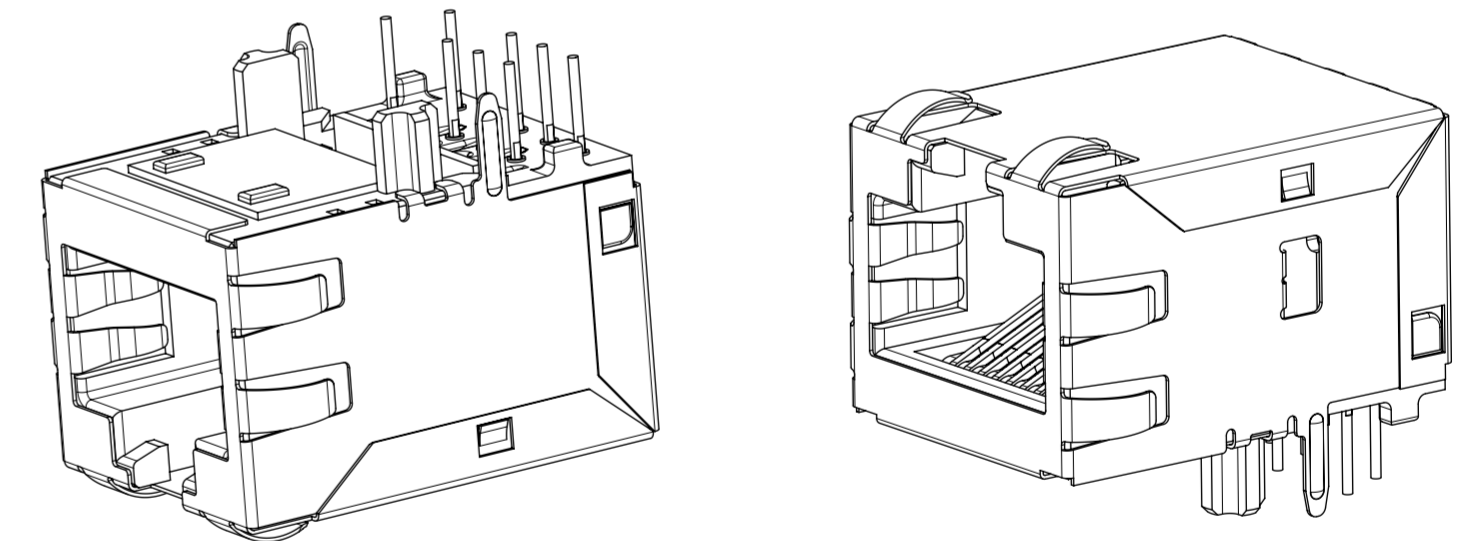
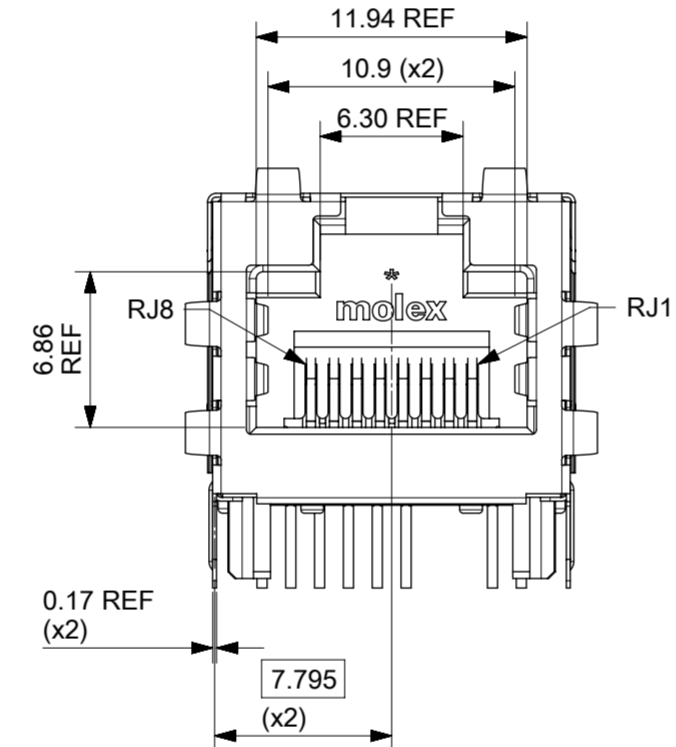
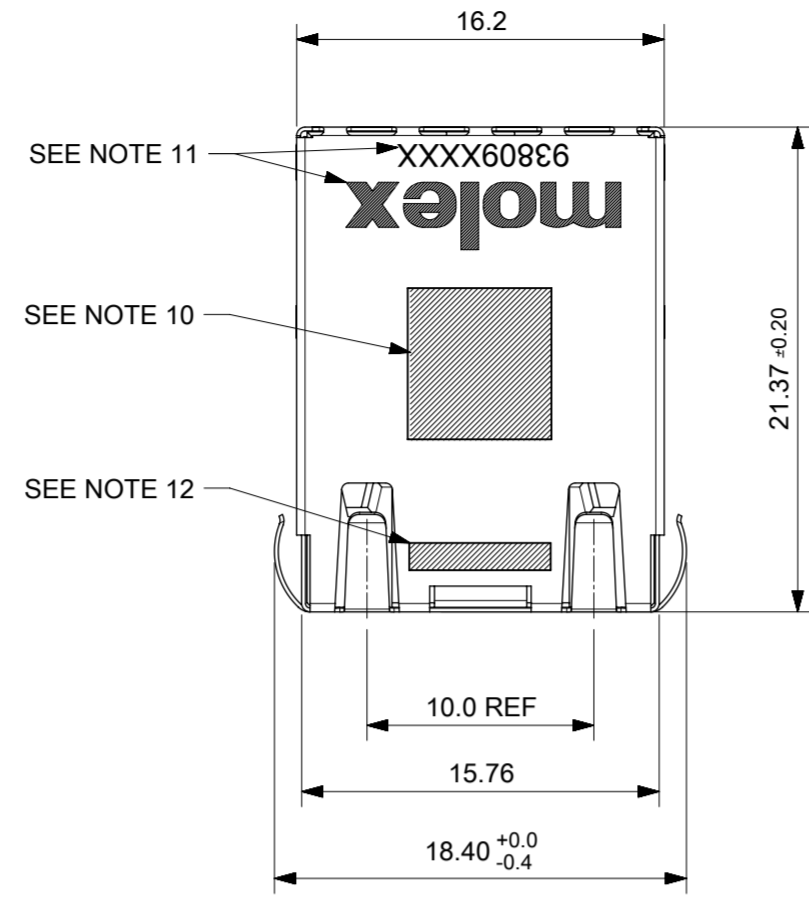

THIS DRAWING CONTAINS INFORMATION THAT IS PROPRIETARY TO MOLEX ELECTRONIC TECHNOLOGIES, LLC AND SHOULD NOT BE USED WITHOUT WRITTEN PERMISSION			
ORIGINAL RELEASE EC NO: 116204 DRWN: DBYRNES CHKD: DBYRNES APPR: STGRIFFIN	2017/03/14	GENERAL TOLERANCES (UNLESS SPECIFIED)	DIMENSION UNITS
	2017/05/05	ANGULAR TOL ± 2.0 °	MM
	2017/05/15	4 PLACES ±	SCALE
		3 PLACES ±	3:1
		2 PLACES ± 0.1	DRWN BY
		1 PLACE ± 0.2	DATE
		0 PLACES ±	DBYRNES
			2017/03/14
			CHK'D BY
			DATE
			DBYRNES
			2017/05/05
			APPR BY
			DATE
			STGRIFFIN
			2017/05/15
			SERIES
			MATERIAL NUMBER
			CUSTOMER
			93809
			SEE SHEET 2
			GENERAL MARKET
			DOCUMENT NUMBER
			938093020
			DOC TYPE
			PSD
			DOC PART
			001
			SHEET NUMBER
			1 OF 3

PART NUMBER	LEFT LED	RIGHT LED
93809-3020	N/A	N/A

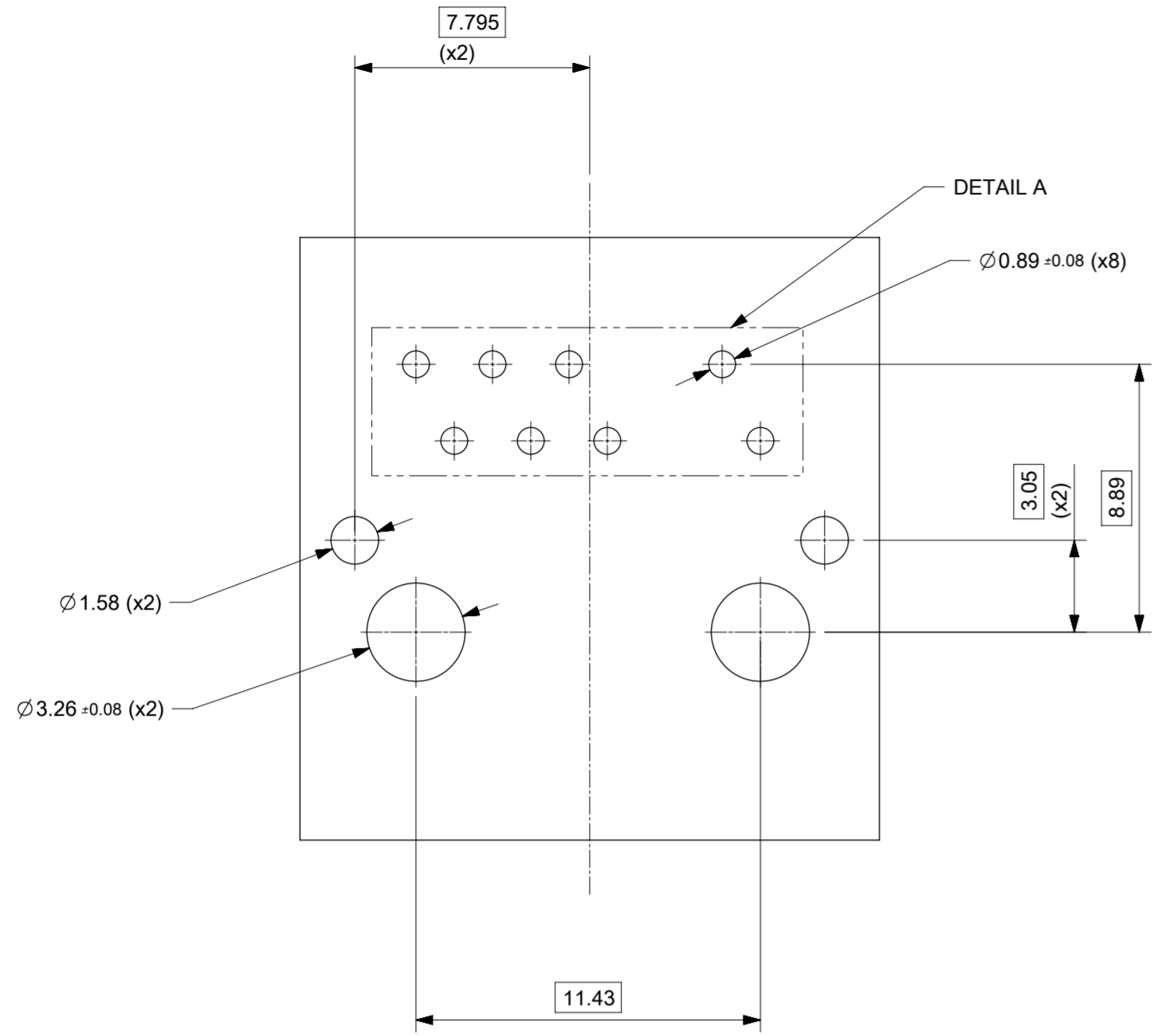

SUGGESTED BOARD LAYOUT
FAST ETHERNET VERSION
COMPONENT SIDE
ALL DIMS REFERENCE DIMS

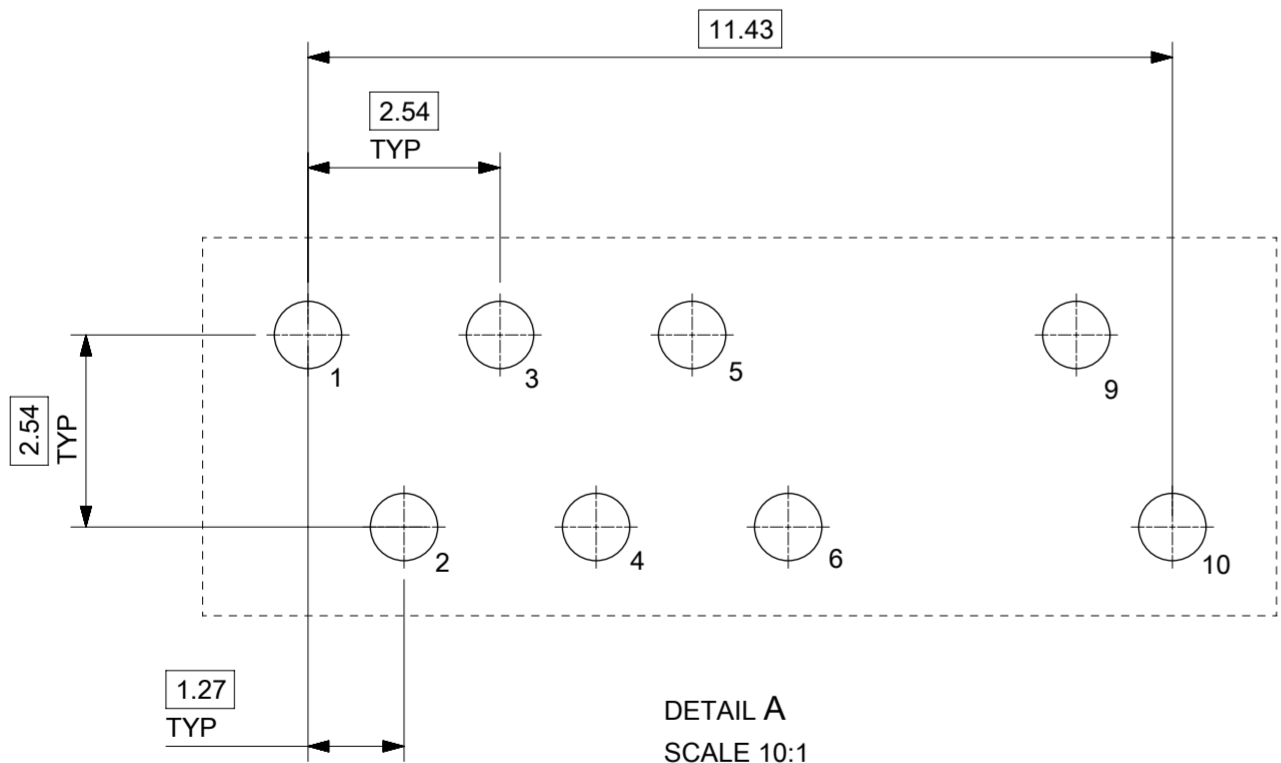

DETAIL A
SCALE 10:1
PIN CONFIGURATION FOR
FAST ETHERNET VERSION

THIS DRAWING CONTAINS INFORMATION THAT IS PROPRIETARY TO MOLEX ELECTRONIC TECHNOLOGIES, LLC AND SHOULD NOT BE USED WITHOUT WRITTEN PERMISSION

ORIGINAL RELEASE EC NO: 116204 DRWN: DBYRNES CHKD: DBYRNES APPR: STGRIFFIN	2017/03/14	2017/05/05	2017/05/15	GENERAL TOLERANCES (UNLESS SPECIFIED)	DIMENSION UNITS	SCALE	
				ANGULAR TOL ± 2.0 °	MM	3:1	
	4 PLACES	±		DRWN BY	DATE		
	3 PLACES	±		DBYRNES	2017/03/14		
			3 PLACES	±			MXMAG POE 10/100 INV PRO COMM TEMP
			2 PLACES	± 0.1			
			1 PLACE	± 0.2			
			0 PLACES	±			
				DRAFT WHERE APPLICABLE MUST REMAIN WITHIN DIMENSIONS	DRAWING SIZE	THIRD ANGLE PROJECTION	PRODUCT CUSTOMER DRAWING
A					A2		SERIES
							MATERIAL NUMBER
							CUSTOMER
							93809
							SEE TABLE
							GENERAL MARKET
							DOCUMENT NUMBER
							938093020
							DOC TYPE
							PSD
							DOC PART
							001
							SHEET NUMBER
							2 OF 3

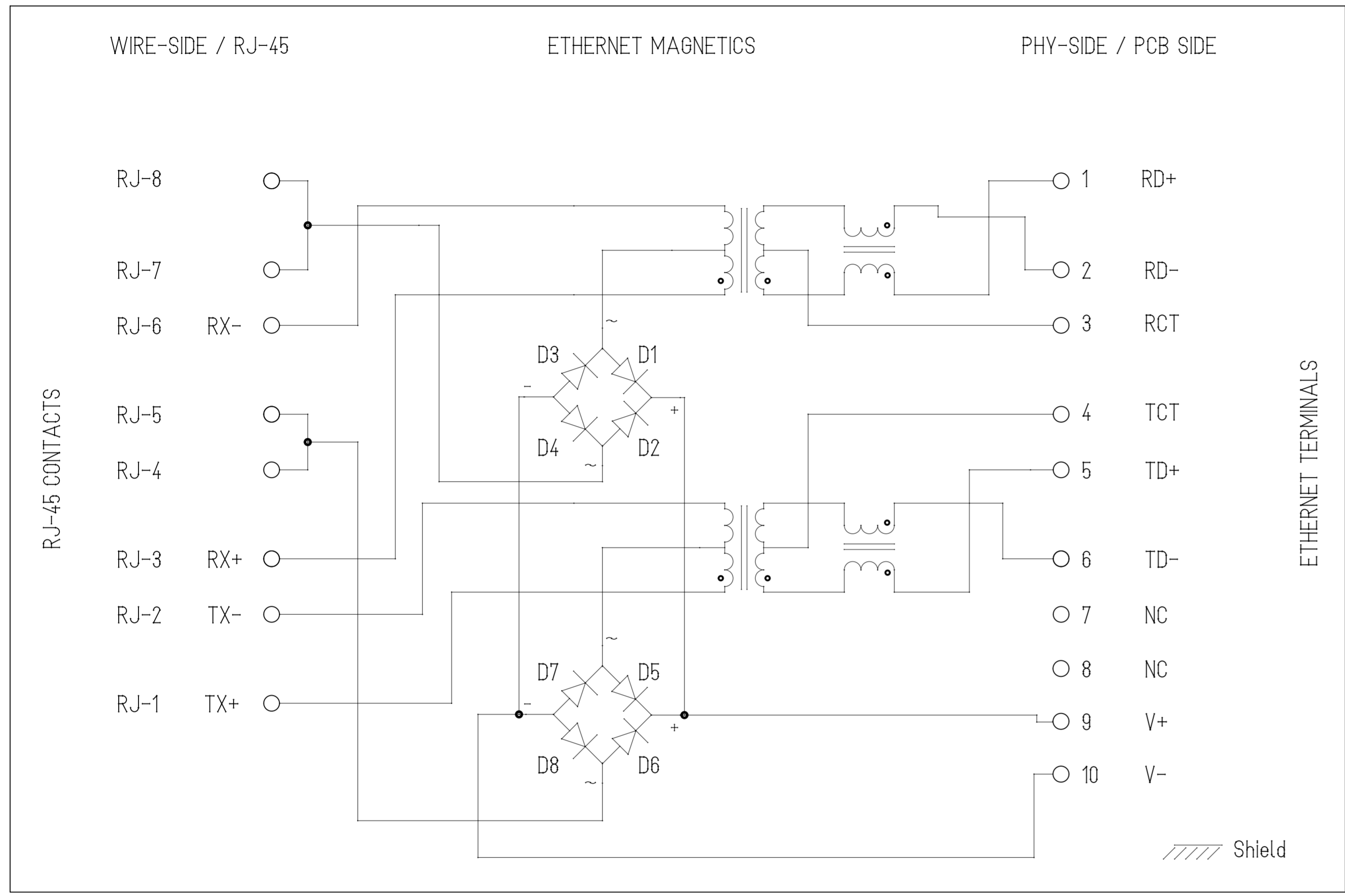

Description	Value	
OCL @100kHz, 0.1V 8mA DC bias (0°C to +70°C)	350µH min.	
Turns ratio	1CT:1CT	
PoE Current	350mA DC	
Transmission characteristics @ 25°C, all four pairs		
Insertion Loss		
Frequency (MHz)	Limits (dB max.)	Typical Values (dB max.)
1.0-9.9 MHz	0.4+0.1*log(F)	0.5 @ 10MHz
10-49.9 MHz	0.5+0.3*log(F/10)	0.7 @ 50MHz
50-79.9 MHz	1+1.4*log(F/80)	1.0 @ 80MHz
80-100 MHz	1.3+3*log(F/100)	1.3 @ 100MHz
Return Loss		
Frequency (MHz)	Limits (dB min.)	Typical Values (dB min.)
1.0-39.9 MHz	18	18 @ 40MHz
40-100 MHz	12-20*log(F/80)	10 @ 100MHz
CMR		
Frequency (MHz)	Limits (dB min.)	Typical Values (dB min.)
1.0-100MHz	30	30 @ 100MHz
Next		
Frequency (MHz)	Limits (dB min.)	Typical Values (dB min.)
1.0-39.9MHz	35	35 @ 40MHz
40-100MHz	33-20*log(F/50)	27 @ 100MHz
Isolation PHY to wire side	2.25kVDC/60sec	

ETHERNET TERMINALS

THIS DRAWING CONTAINS INFORMATION THAT IS PROPRIETARY TO MOLEX ELECTRONIC TECHNOLOGIES, LLC AND SHOULD NOT BE USED WITHOUT WRITTEN PERMISSION

ORIGINAL RELEASE EC NO: 116204 DRWN: DBYRNES CHK'D: DBYRNES REV: APPR: STGRIFFIN	2017/03/14	2017/05/05	2017/05/15	GENERAL TOLERANCES (UNLESS SPECIFIED)	DIMENSION UNITS	SCALE	
	4 PLACES	±		ANGULAR TOL ± 2.0 °	MM	1:1	
	3 PLACES	±			DRWN BY	DATE	
	2 PLACES	±	0.1		DBYRNES	2017/03/14	
1 PLACE	±	0.2		CHK'D BY	DATE	PRODUCT CUSTOMER DRAWING SERIES: 93809 MATERIAL NUMBER: SEE SHEET 2 CUSTOMER: GENERAL MARKET DOCUMENT NUMBER: 938093020 DOC TYPE: PSD DOC PART: 001 SHEET NUMBER: 3 OF 3	
0 PLACES	±			DBYRNES	2017/05/05		
DRAFT WHERE APPLICABLE MUST REMAIN WITHIN DIMENSIONS		DRAWING SIZE	THIRD ANGLE PROJECTION	APPR BY	DATE		
A	A2			STGRIFFIN	2017/05/15		