

Brief Description

The SSC Sensor Replacement Board is included in IDT's modular SSC Evaluation Kits, which provide a very simple and intuitive method for evaluating both hardware and software for IDT's resistive sensor signal conditioner (SSC) IC products. SSC Evaluation Kit components include the SSC Evaluation Software, the SSC Communication Board, and the SSC Evaluation Board designed for the SSC product under test. Simply interchanging the SSC Evaluation Boards for different SSC ICs and changing software settings allows comparison of the advantages of each product. The Sensor Replacement Board (SRB) can be used with the kit to evaluate any IDT SSC IC product for resistive sensors by providing an artificial replacement for the bridge sensor and an external diode for external temperature measurement if applicable to the SSC IC.

The SSC Sensor Replacement Board can expedite the design process because the SSC IC can be calibrated and tested even before the actual sensor element has been selected. A simple "test-on-the-desk" is possible without expensive equipment.

The SSC Sensor Replacement Board connects to the SSC Evaluation Board via a 50-pin connector that allows "plug & play" connectivity. Test points provide access to all signal lines for the replacement sensor enabling a simple system check.

An on-board potentiometer creates an adjustable voltage divider for simulating the differential bridge sensor voltage V_{BR_DIFF} to be conditioned by the SSC IC (VINN and VINP signals on the SRB) for an output that is ratiometric to the bridge supply voltage V_{BR} (voltage divider supply voltage). An on-board 1N4148 diode can be used as an external temperature sensor depending on the SSC IC.

Features

- Simple installation via "Plug & Play" connectivity
- Power supplied by the SSC Evaluation Board
- Access to all sensor signal lines of the replacement sensor on board

Benefits

- Basic system evaluation using the replacement sensor
- External temperature sensing via on-board diode for SSC ICs with an external temperature sensor input
- Modular kit design allows reusing SSC Sensor Replacement Board with different SSC Evaluation Boards for comparing IDT's SSC ICs

Related Products

- SSC Communication Board – provides an interface to user's computer for communicating commands, reading measurement results, and calibration
- SSC Evaluation Board for SSC IC under test
- SSC Evaluation Software for SSC IC under test

SSC Sensor Replacement Board Features

Test points for easy access to bridge and temperature signals (VTN=IR_Temp)

External temperature diode (1N4148)

Potentiometer for simulating bridge

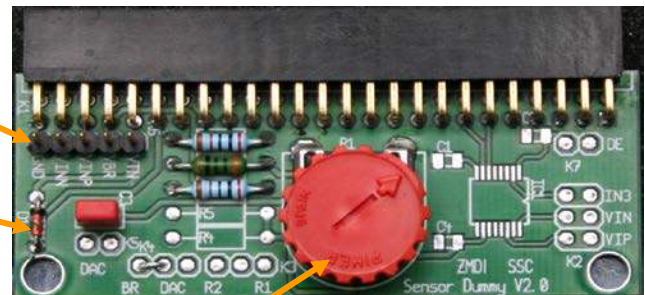

(L x W x H = 67mm x 34mm x 15 mm)

Important Note

Restrictions in Use

The software and the hardware for the ZSC31xxx / ZSSC3xxx SSC Evaluation Kits, including the SSC Sensor Replacement Board, are designed for IC evaluation, laboratory setup and module development only.

The ZSC31xxx / ZSSC3xxx Evaluation Kit hardware and software must not be used for module production or production test setups.

Disclaimer

IDT shall not be liable for any damages arising out of defects resulting from:

- (i) delivered hardware and software
- (ii) non-observance of instructions contained in this manual, or
- (iii) misuse, abuse, use under abnormal conditions or alteration by anyone other than IDT.

To the extent permitted by law, IDT hereby expressly disclaims and user expressly waives any and all warranties, whether express, implied, or statutory, including, without limitation, implied warranties of merchantability and of fitness for a particular purpose, statutory warranty of non-infringement and any other warranty that may arise by reason of usage of trade, custom, or course of dealing.

Contents

1	Electrical Specifications.....	3
2	SSC Sensor Replacement Board Overview.....	3
3	Ordering Information	4
4	Related Documents.....	4
5	Document Revision History	5

1 Electrical Specifications

PARAMETER	SYMBOL	CONDITIONS	MIN	TYP	MAX	UNITS
Ambient temperature range ¹⁾	T _{AMB}		+10		+45	°C
External Bridge Supply Voltage	V _{BR}			5	15	VDC
Simulated Sensor Bridge Resistance	R _{BR}		3.800	4.050	4.205	kΩ
Typical Adjustable R _{BR} Range			3.950		4.050	kΩ

1. Important: The SSC Communication Board is designed for operation at room temperature only. Do not place this board in temperature chambers during calibration.

2 SSC Sensor Replacement Board Overview

The SSC Sensor Replacement Board (SRB) is a component of IDT's SSC Evaluation Kits for IDT sensor signal conditioner (SSC) ICs for resistive sensor bridges. It functions with the SSC Communication Board and the SSC Evaluation Board for the SSC IC under test to enable evaluation and calibration of the IC. An example of the SRB being used in the Evaluation Kit is given in Figure 2.1.

Figure 2.1 SSC Evaluation Kit Example—ZSC31014 SSC Evaluation Kit with Communication Board V3.3

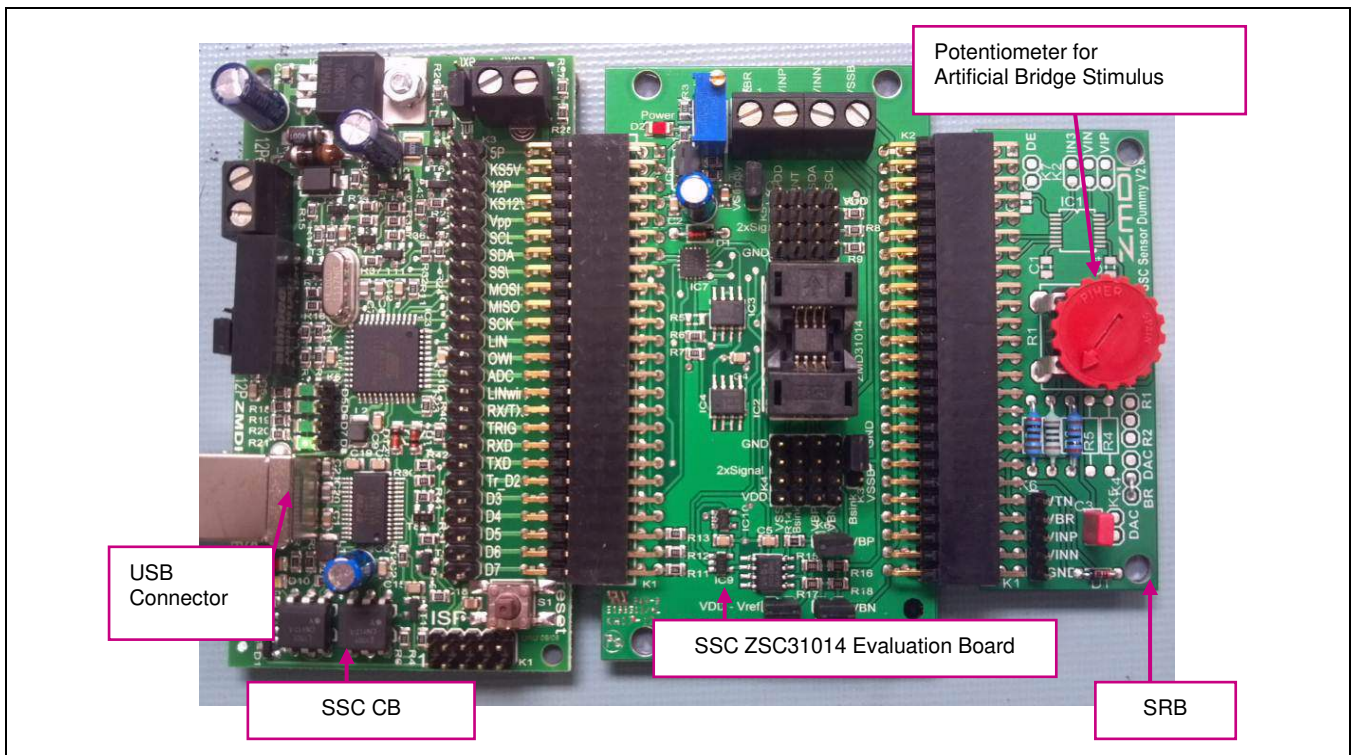
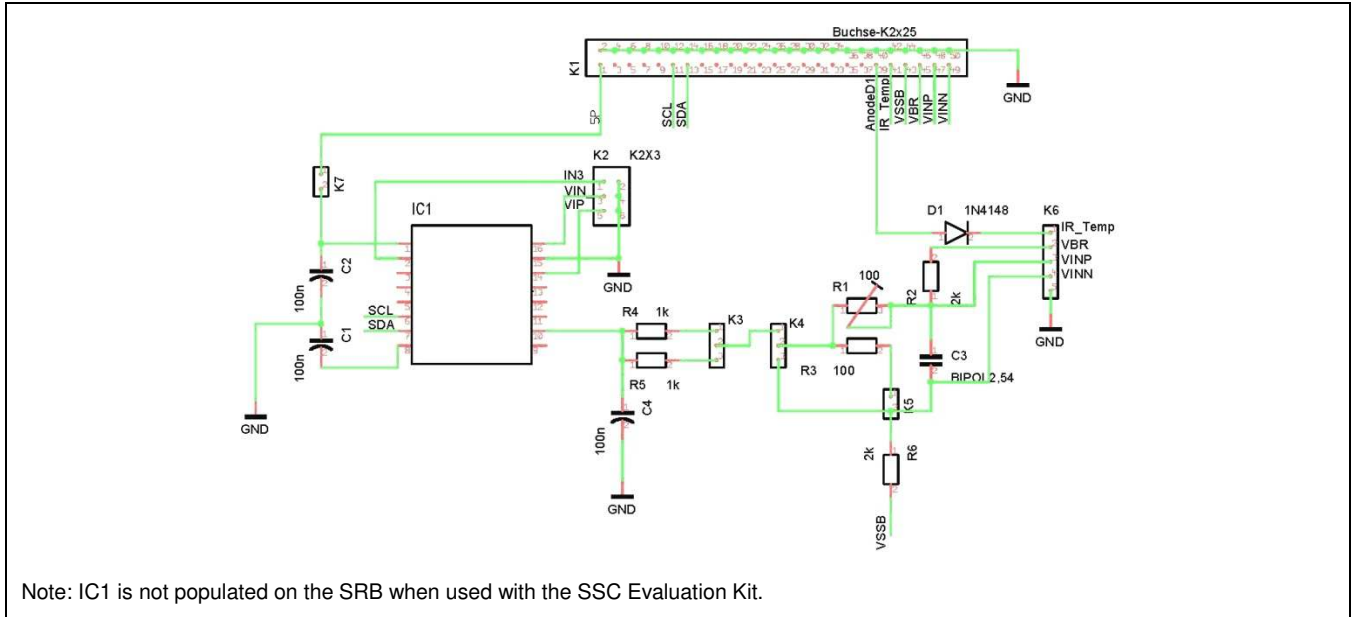

Figure 2.2 SSC Sensor Replacement Board (SRB) Schematic



3 Ordering Information

Product Sales Code	Description	Package
SSC Sensor Replacement Board V2.0	SSC Sensor Replacement Board V2.0	Circuit Board
Note: Refer to the <i>SSC Evaluation Kit Feature Sheet</i> for part order numbers and content descriptions for the Evaluation Kits		

4 Related Documents

Document
SSC Communication Board Data Sheet
SSC Evaluation Kit Feature Sheet

Visit IDT's website at www.IDT.com or contact your nearest sales office for the latest version of these documents.

5 Document Revision History

Revision	Date	Description
1.04	November 15, 2013	Addition of temperature specifications and warnings. Clarification that U1 is not populated when SRB is used in SSC Evaluation Kits. Addition of kit example illustration. Addition of "Related Products" section on page 2. Update for contact information and imagery for cover and headers.
	March 29, 2016	Changed to IDT branding.

IMPORTANT NOTICE AND DISCLAIMER

RENESAS ELECTRONICS CORPORATION AND ITS SUBSIDIARIES (“RENESAS”) PROVIDES TECHNICAL SPECIFICATIONS AND RELIABILITY DATA (INCLUDING DATASHEETS), DESIGN RESOURCES (INCLUDING REFERENCE DESIGNS), APPLICATION OR OTHER DESIGN ADVICE, WEB TOOLS, SAFETY INFORMATION, AND OTHER RESOURCES “AS IS” AND WITH ALL FAULTS, AND DISCLAIMS ALL WARRANTIES, EXPRESS OR IMPLIED, INCLUDING, WITHOUT LIMITATION, ANY IMPLIED WARRANTIES OF MERCHANTABILITY, FITNESS FOR A PARTICULAR PURPOSE, OR NON-INFRINGEMENT OF THIRD PARTY INTELLECTUAL PROPERTY RIGHTS.

These resources are intended for developers skilled in the art designing with Renesas products. You are solely responsible for (1) selecting the appropriate products for your application, (2) designing, validating, and testing your application, and (3) ensuring your application meets applicable standards, and any other safety, security, or other requirements. These resources are subject to change without notice. Renesas grants you permission to use these resources only for development of an application that uses Renesas products. Other reproduction or use of these resources is strictly prohibited. No license is granted to any other Renesas intellectual property or to any third party intellectual property. Renesas disclaims responsibility for, and you will fully indemnify Renesas and its representatives against, any claims, damages, costs, losses, or liabilities arising out of your use of these resources. Renesas' products are provided only subject to Renesas' Terms and Conditions of Sale or other applicable terms agreed to in writing. No use of any Renesas resources expands or otherwise alters any applicable warranties or warranty disclaimers for these products.

(Disclaimer Rev.1.0 Mar 2020)

Corporate Headquarters

TOYOSU FORESIA, 3-2-24 Toyosu,
Koto-ku, Tokyo 135-0061, Japan
www.renesas.com

Contact Information

For further information on a product, technology, the most up-to-date version of a document, or your nearest sales office, please visit:
www.renesas.com/contact/

Trademarks

Renesas and the Renesas logo are trademarks of Renesas Electronics Corporation. All trademarks and registered trademarks are the property of their respective owners.