

LOC	DIST	ZONE	LTR	DESCRIPTION	DATE	APPD
G	14			RELEASED PER 0720-0008-93	2-1-93	18 DAP

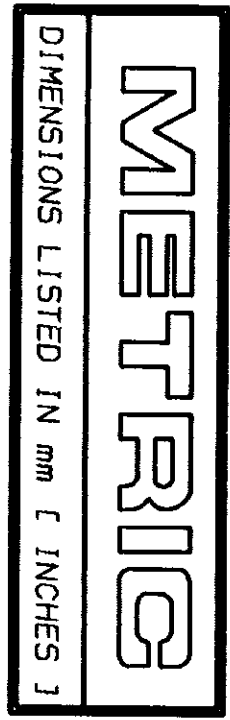

AMP WIRE RANGE	UL E13288 Listed
16-14HD AWG STRANDED	16-14HD AWG STRANDED
LR7189 Certified	MILITARY P/N AND CLASS
NOT CERTIFIED	NOT APPLICABLE

STAMP AMP 16-14HD* APPROX AS SHOWN

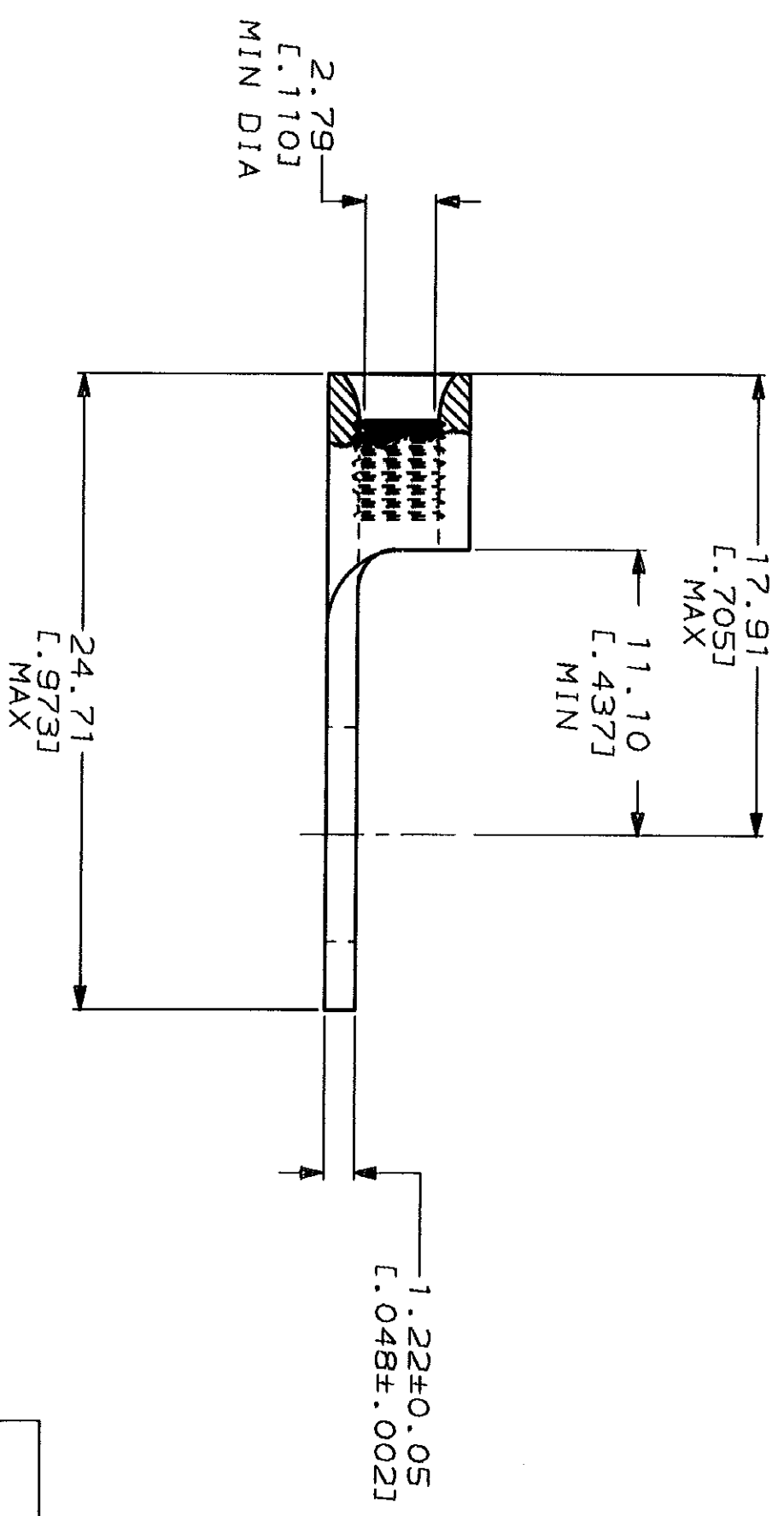
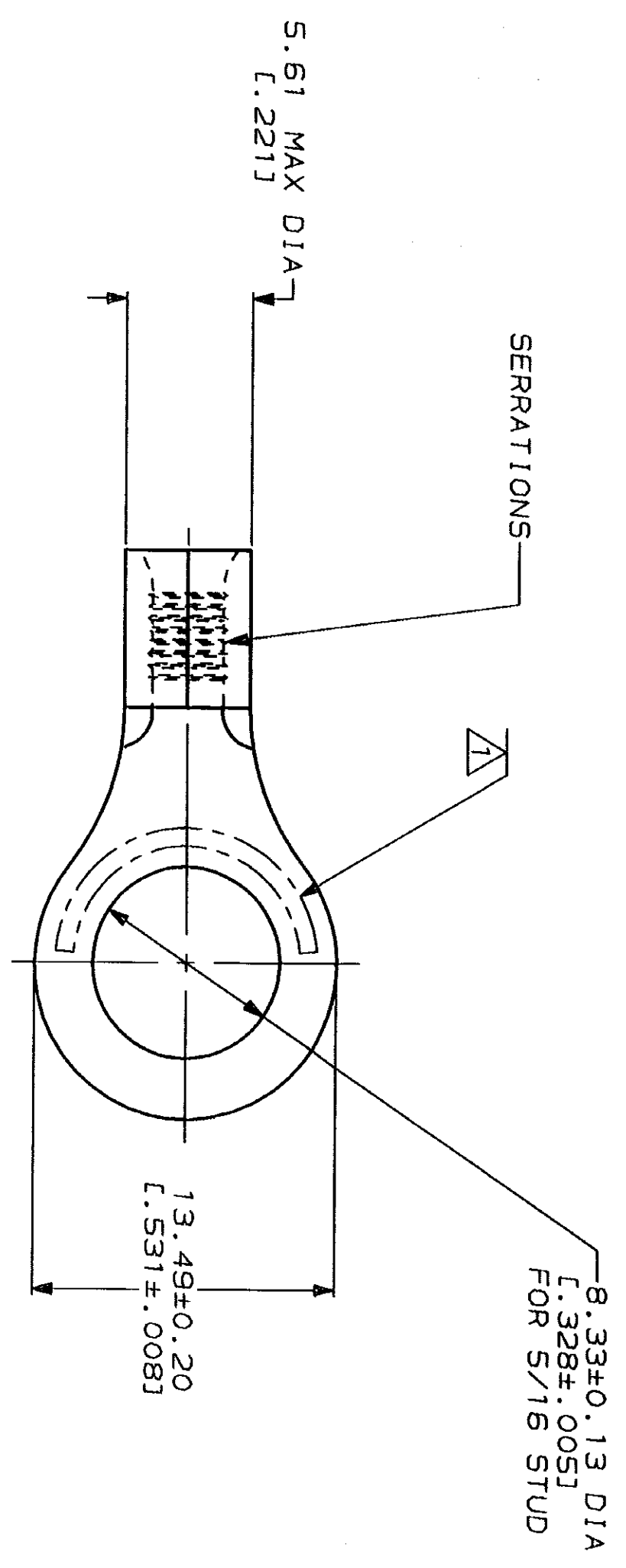

**AMP INCORPORATED
CUSTOMER SERVICE SYSTEMS**

FOR ADDITIONAL PRODUCT INFORMATION OR COPIES OF DRAWINGS AND TECHNICAL DOCUMENTS	PRODUCT INFORMATION CENTER 1-800-522-6752
FOR APPLICATION TOOLING INFORMATION	TOOLING ASSISTANCE CENTER 1-800-722-1111
FOR ORDER ENTRY	1-800-526-5142

MAX RECOMMENDED OPERATING TEMPERATURE: 170°C MAX

VOLTAGE RATING: NOT APPLICABLE

WIRE CROSS SECTIONAL AREA RANGE: 1.04-2.62mm² [2,050-5,180] CIR MILS STRANDED

THIS DRAWING IS A CONTROLLED DOCUMENT FOR THE CONTROLLING ENGINEERING ORGANIZATION AND SHOULD BE CONTACTED FOR THE LATEST REVISION.

DO NOT SCALE PRINT. UNLESS SPECIFIED DIMENSIONS IN MILLIMETERS - TOLERANCES ON: 2 PLC DEC ± - - 3 PLC DEC ± - - ANGLES MATERIAL COPPER PER ASTM B-152 ANNEALED

FINISH TIN PLATE 0.00254 [.000100] MIN THK PER MIL-T-10727

DR 2-1-93 TA BRINKMAN
CHK 2-1-93 DA PATTERSON
APPD 2-1-93 DE MILLER
APPD 2-1-93 JL MECKLEY
PRODUCT SPEC
APPLICATION SPEC
WEIGHT

AMP AMP Incorporated
Harrisburg, PA 17105-3608

TERMINAL, RING TONGUE,
HEAVY DUTY, BUDGET

SIZE	CAGE CODE	DRAWING NO
SCALE	00779	G=33647
4:1		

33647
PART NO