



## TPT300V

### IR Pyrometer

#### Key Features

- **Contactless Temperature Measurement**
- **High Accuracy**
- **Wide Temperature Range**
- **Digital and Analogue Interface**
- **Industrial Usage (IP65)**

TPT300V is a contactless temperature measuring system - called pyrometer - based on the detection of infrared radiation. TPT300V is equipped with a lens and an infrared sensor (Thermopile) in front. It has to be pointed at the target object.

The basic working principle is:

- Detection of infrared radiation with a Thermopile sensor
- Further analogue signal processing
- Calculation of the objects temperature using a microcontroller
- Providing the objects temperature at digital or analogue output

The main fields of applications are temperature measuring in industrial applications i.e. at moving or inaccessible parts

## FEATURES

- 0°C – 300°C Measurement Range
- 9V – 24V Supply Voltage Range
- RS232 Interface & Analogue Voltage Output
- IP65 protected

## APPLICATIONS

- Contactless Temperature Measurement
- Industrial Process Control

## ABSOLUTE MAXIMUM RATINGS

- Absolute maximum ratings are limiting values of permitted operation and should never be exceeded under the worst possible conditions either initially or consequently. If exceeded by even the smallest amount, instantaneous catastrophic failure can occur. And even if the device continues to operate satisfactorily, its life may be considerably shortened.

Parameter	Symbol	Conditions	Min	Typ	Max	Unit
Supply Voltage	Vcc	Measured versus GND	-1		28	V
Storage Temperature	Tstor		-20		85	°C

## OPERATING CONDITIONS

Parameter	Symbol	Conditions	Min	Typ	Max	Unit
Supply Voltage	Vcc	Measured versus GND	9		24	V
Supply Current	I	Full ambient temp. range, no output load		22		mA
Thermal Emission Coefficient of Object	$\epsilon$	Adjustable via RS232	10		100	%
Field of View	FOV			$\pm 5$		°
Digital Output Rate		Adjustable	0.1		10	Hz
Digital Output Settings			9600 Baud, 8 Bit, No Parity, 1 Stop Bit			

## OPERATING CHARACTERISTICS

Parameter	Symbol	Conditions	Min	Typ	Max	Unit
Object Temperature Range	Tobj	Digital output Analog output	0 12		300 288	°C
Ambient Temperature Range	Tamb		0		85	°C
Spectral Sensitivity	S		8		14	µm
Accuracy of Target Temp. Measuring	Acc1	Tambient = 25°C	± 1% of Full Scale Range resp. ± 3°C			°C
Accuracy of Target Temp. Measuring	Acc2	Full ambient temp. range	± 1.5% of Full Scale Range resp. ± 4.5°C			°C
Resolution Digital	Res		0.3			°C
Analog Output Characteristics			T[°C] x 5V/300°C			V
Analog Output Range			0.2 – 4.8			V
Resolution Analog			0.3			°C
Analog Output Source Resistance			40			Ω
Housing			Stainless steel			
Protection class			IP 65			

## MECHANICAL DIMENSIONS

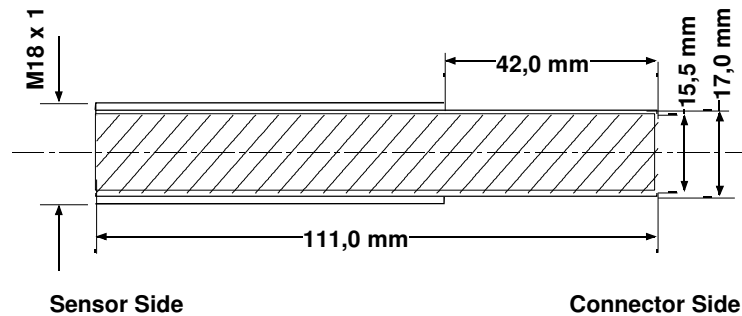

## TERMINALS

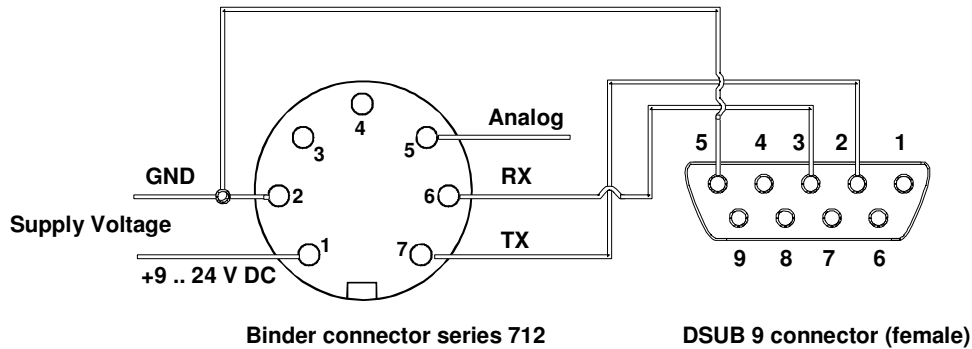

**Please take care: pin numbers are marked on the Binder and on most DSUB connectors!**

Pin	Symbol	Description	Typ
1	+VS	Supply Voltage	Supply
2	GND	Ground potential	Supply
3	NC		
4	NC		
5	AN	Analog Output (Voltage)	Analog Output
6	RX	Receive Data (RS232)	Digital Input/Output
7	TX	Transmit Data (RS232)	Digital Input/Output

## FUNCTION

### RS232 PROTOCOL

Fixed RS232 settings: 9600 Baud, 8 Bit, No Parity, 1 Stop Bit

### TPT MODES

There are two modes implemented in TPT sensors: the Free Running mode and the On Request mode. In the Free Running mode the sensor cyclically sends measuring results via RS232. In this mode no further communication (for instance changing sensor parameters) is possible. The only telegram which is accepted in this mode is the "Set On Request Mode" telegram, which stops sensor output.

In On Request mode the sensor only sends data via RS232 after user has sent any request telegram. Only in this mode the changing of sensor parameters is possible.

NOTE: Updating the analog output is directly correlated with updating the RS232 output. Only if output data are sent via RS232 the analog output is updated. Two cases are possible: the "Request Result Data" telegram causes updating serial and analog output and - on the other hand - the cyclically sending data in Free Running Mode.

**FACTORY SETTINGS**

After delivery following parameters are set:

Parameter	Default Setting
Output Mode	Free Running
Output Format	Object and Ambient Temperature
Output Rate	100ms
Emissivity	98%

**COMMANDS**

command	to the sensor	sensor response	explanation
Request Software Version and Serial Number	„V“	“HL-Planartechnik “ “TPT V2.2 yywwnnn-2” <CR> <LF>	Manufacturer company, software version, serial number with yy =Year, ww = weak of year, nnn = consecutive number, -2 = product code for TPT300V
Set Output Mode “Free Running”	“F”	“F”	“Free Running” mode is active
Set Output Mode “On Request”	“f”	“f”	“On Request” mode is active
Set Output Format “Object and Ambient Temperature”	“I”	“I”	Format “Object and Ambient Temperature” is active
Set Output Format “Object Temperature”	“i”	“i”	Format “Object Temperature” is active
Set Emissivity Factor	“e” <Emissivity>	“e” <Emissivity>	Emissivity in percentage (10..100), 1 Byte Binary-Format,
Read Emissivity Factor	“E”	“99”	Answer Emissivity in percentage (10..100); ASCII-Format
Request Result Data (While Output Format “Object and Ambient Temperature”)	“R”	“+255:+784” <CR> <LF>	With +255 = sensor temperature in tenth of degree C (1-3 digit with sign) +784 = object temperature in tenth of degree C (1-4 digit with sign);
Request Result Data (While Output Format “Object Temperature”)	“R”	“+784” <CR> <LF>	With +784 = object temperature in tenth of degree C (1-4 digit with sign)
Software Reset	“q”	-	No Echo. It takes about 1 second until software reset is done and sensor acts normal (as after power-up)
Set Output Data Rate for Output Mode “Free Running”	“O” “(Data Rate Code)”	“O” “(Data Rate Code)”	(Note 1), ASCII-Format

“” = ASCII-Format, <> = Binary-Format, <CR>= Carriage Return, <LF> = Line Feed

No reset is necessary to activate the new settings.

Note 1:

Data Rate Code	Output Data Rate
“0”	100 ms
“1”	500 ms
“2”	1000 ms
“3”	5000 ms
“4”	10000 ms

