

Features

- ESD Protect for Low-Voltage Differential Signaling (LVDS) channels
- Protects four I/O lines
- Provide ESD protection for each line to **IEC 61000-4-2 (ESD) $\pm 30\text{kV}$ (air), $\pm 25\text{kV}$ (contact)**
IEC 61000-4-4 (EFT) 80A (5/50ns)
IEC 61000-4-5 (Lightning) 15A (8/20 μs)
- **For operating voltage of 3.3V and below**
- **Low capacitance : 2.0pF typical**
- Fast turn-on and Low clamping voltage
- Array of ESD rated diodes with internal equivalent TVS (Transient Voltage Suppression) diode
- Solid-state silicon-avalanche and active circuit triggering technology
- **Green part**

Applications

- LVDS Interface
- USB2.0 Data lines protection
- Control Signal Lines Protection
- SIM ports
- Monitors and Flat Panel Displays
- Notebook and PC Computers
- Ethernet port: 10/100/1000 Mb/s
- Consumer Electronics
- Set Top Box

Description

AZ1013-04F is a high performance design which includes surge rated diode arrays to protect high speed data interfaces. The AZ1013-04F has been specifically designed to protect sensitive components, which are connected to data and transmission lines, from over-voltage caused by Electrostatic Discharging (ESD), Electrical Fast Transients (EFT), and Lightning.

AZ1013-04F is a unique design which includes surge rated, low capacitance steering diodes and a unique design of clamping cell which is an equivalent TVS diode in a single package. During transient conditions, the steering diodes direct the transient to either the internal ESD line or to ground line. The internal unique design of clamping cell prevents over-voltage on the internal ESD line and on the I/O line, which is protecting any downstream components.

AZ1013-04F may be used to meet the ESD immunity requirements of IEC 61000-4-2, Level 4 ($\pm 15\text{kV}$ air, $\pm 8\text{kV}$ contact discharge).

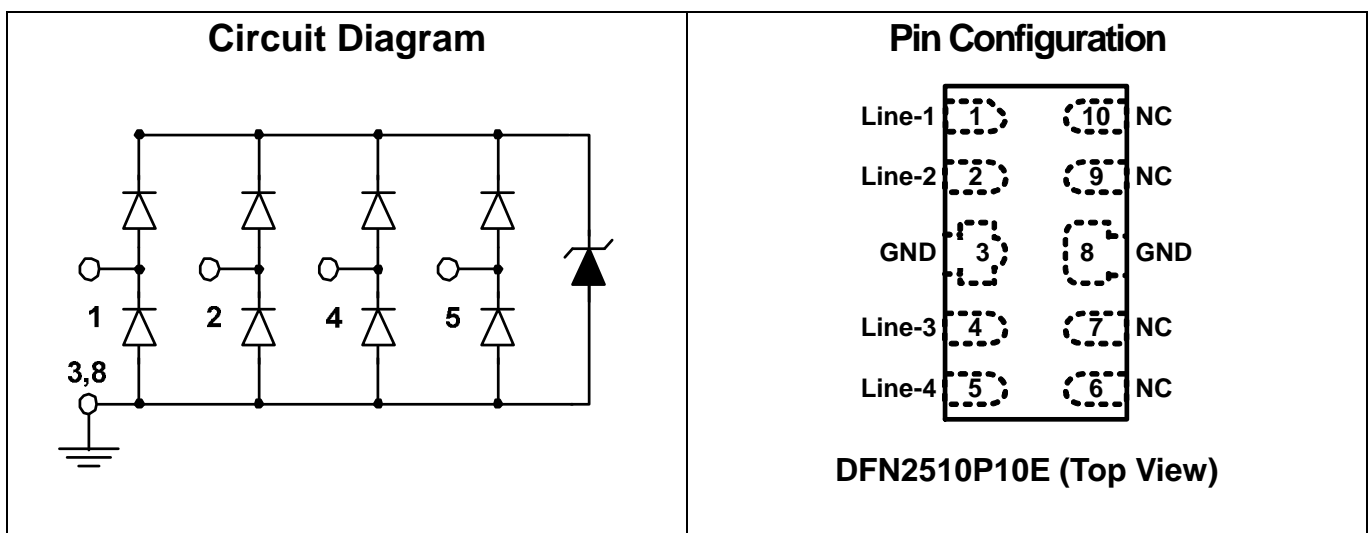



SPECIFICATIONS

ABSOLUTE MAXIMUM RATINGS			
PARAMETER	SYMBOL	RATING	UNITS
Peak Pulse Current (tp =8/20μs)	I _{PP}	15	A
Operating Voltage (I/O pin-GND)	V _{DC}	(GND – 0.5) to 3.6	V
ESD per IEC 61000-4-2 (Air)	V _{ESD}	30	kV
ESD per IEC 61000-4-2 (Contact)		25	
Lead Soldering Temperature	T _{SOL}	260 (10 sec.)	°C
Operating Temperature	T _{OP}	-55 to +85	°C
Storage Temperature	T _{STO}	-55 to +150	°C

ELECTRICAL CHARACTERISTICS						
PARAMETER	SYMBOL	CONDITIONS	MIN	TYP	MAX	UNITS
Reverse Stand-Off Voltage	V _{RWM}	Pin-1,-2,-4,-5 to pin-3,-8, T=25 °C			3.3	V
Channel Leakage Current	I _{CH-Leak}	V _{Pin-1,-2,-4,-5} = 3.3V, V _{Pin-3,-8} = 0V, T=25 °C			1	μA
Reverse Breakdown Voltage	V _{BV}	I _{BV} = 1mA, T=25 °C, Pin-1,-2,-4,-5 to pin-3,-8	4.5			V
Forward Voltage	V _F	I _F = 15mA, T=25 °C, pin-3,-8 to pin-1,-2,-4,-5		0.9	1.2	V
ESD Clamping Voltage	V _{clamp}	IEC 61000-4-2 +6kV, T=25 °C, Contact mode, any I/O pin to Ground		7.8		V
ESD Dynamic Turn-on Resistance	R _{dynamic}	IEC 61000-4-2, 0~+6kV, T=25 °C, Contact mode, any I/O pin to Ground		0.14		Ω
Lightning Clamping Voltage	V _{lightning}	I _{PP} =5A, tp=8/20μs, T=25 °C Any Channel pin to Ground		5.2		V
Channel Input Capacitance	C _{IN}	V _{pin-3,-8} = 0V, V _{IN} = 1.65V, f = 1MHz, T=25 °C, any I/O pin to Ground		2.0	2.5	pF
Channel to Channel Input Capacitance	C _{CROSS}	V _{pin-3,-8} = 0V, V _{IN} = 1.65V, f = 1MHz, T=25 °C, between I/O pins		0.25	0.5	pF

Typical Characteristics

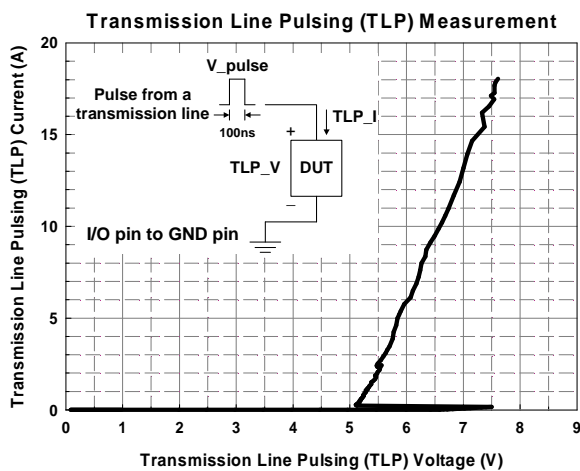
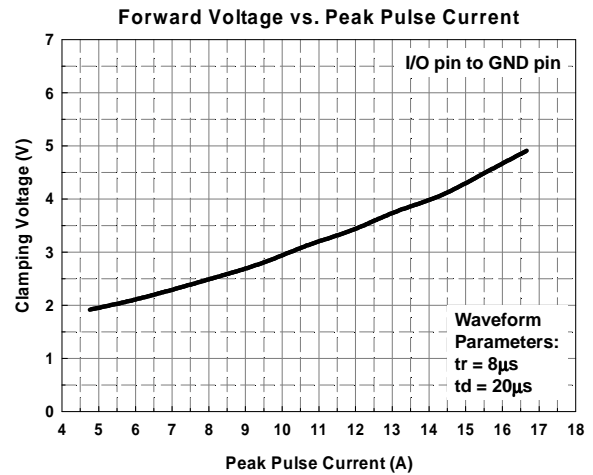
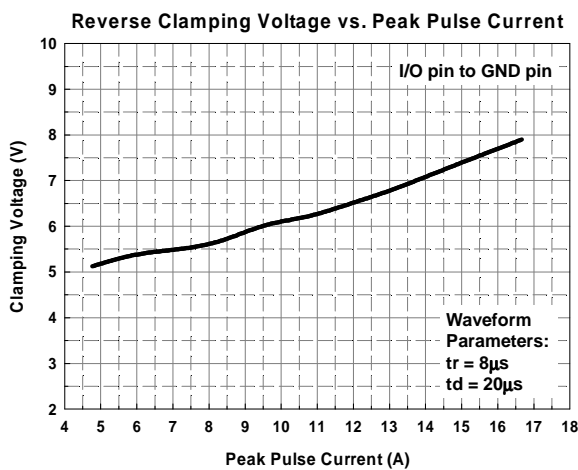
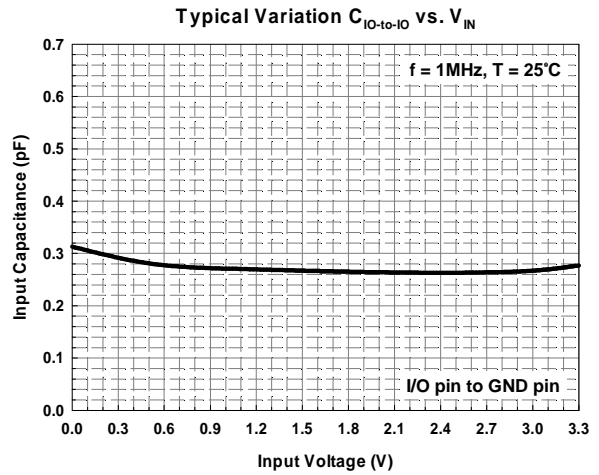
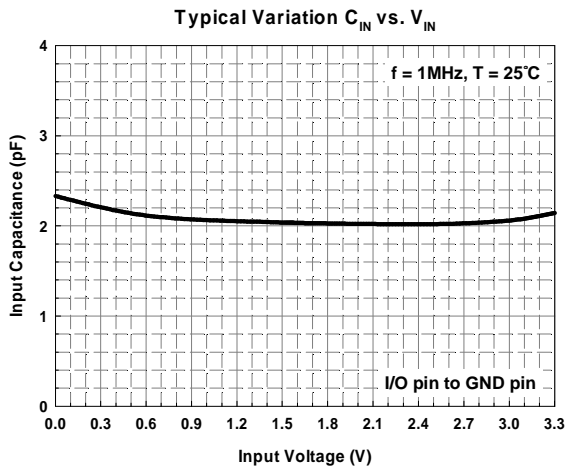



**PACKAGE OUTLINE
(DFN2510P10E)**

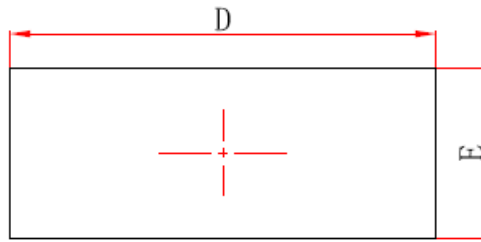

TOP VIEW (unit in mm)

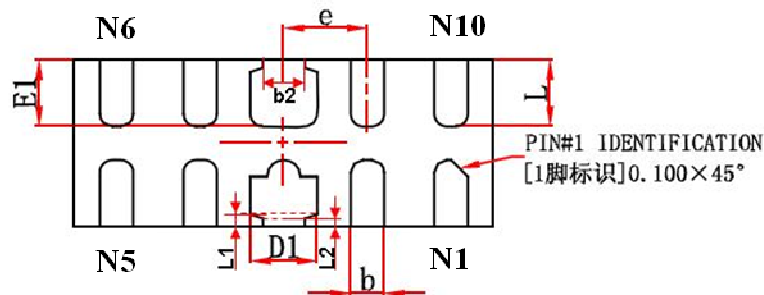

BOTTOM VIEW (unit in mm)

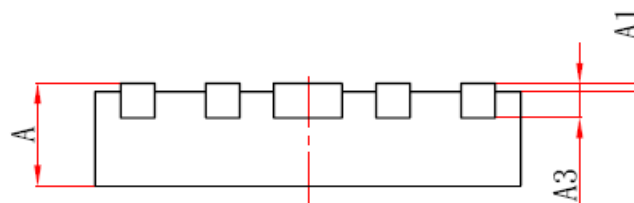

SIDE VIEW (unit in mm)

Symbol	Millimeters		Inches	
	min	max	min	max
A	0.40	0.55	0.016	0.022
A1	0.00	0.05	0.000	0.002
A3	0.152REF.		0.006 BSC	
D	2.45	2.55	0.096	0.100
E	0.95	1.05	0.037	0.041
D1	0.35	0.45	0.014	0.018
E1	0.35	0.45	0.014	0.018
b	0.15	0.25	0.006	0.010
e	0.5 BSC		0.019 BSC	
L1	0.075 REF		0.0029 REF	
L2	0.05 REF		0.0019 REF	
b2	0.20	0.30	0.0079	0.012
L	0.35	0.45	0.014	0.018



LAND LAYOUT

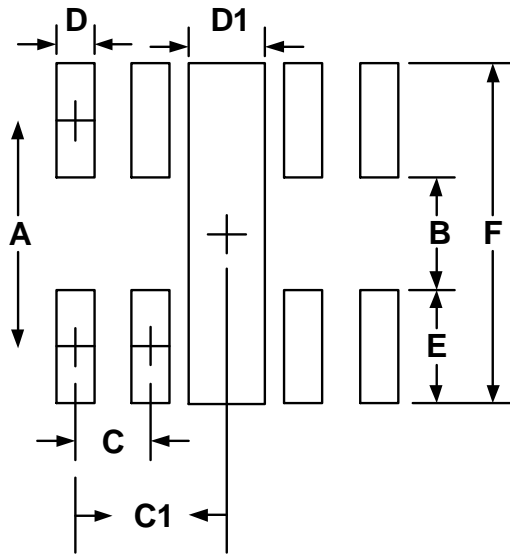

Dimensions		
Index	Millimeter	Inches
A	0.875	0.034
B	0.20	0.008
C	0.50	0.02
C1	1.00	0.039
D	0.25	0.01
D1	0.4	0.016
E	0.675	0.027
F	1.55	0.061

Notes:

This LAND LAYOUT is for reference purposes only. Please consult your manufacturing partners to ensure your company's PCB design guidelines are met.

MARKING CODE



153 = Device Code
X = Date Code
Y = Control Code

Part Number	Marking Code
AZ1013-04F (Green Part)	153XY

Note. Green means Pb-free, RoHS, and Halogen free compliant.

Ordering Information

PN#	Material	Type	Reel size	MOQ	MOQ/internal box	MOQ/carton
AZ1013-04F.R7G	Green	T/R	7 inch	3,000/reel	4 reel= 12,000/box	6 box =72,000/carton



Revision History

Revision	Modification Description
Revision 2014/07/30	Preliminary Release.
Revision 2014/11/20	Formal Release.