

THIS DRAWING IS UNPUBLISHED. RELEASED FOR PUBLICATION
 © COPYRIGHT - By - ALL RIGHTS RESERVED.

REVISIONS				
P	LTR	DESCRIPTION	DATE	APVD
C3		REVISED PER ECR-19-010493	18JUL2019	SR JB

SPECIFICATIONS:
 SINGLE POLE DOUBLE THROW
 BREAK-BEFORE-MAKE

MATERIALS:
 FRAME: STEEL, TIN PLATE
 BOARD: PHENOLIC, NATURAL
 ACTUATOR: NYLON 66 UL94HB, FINISH: BLACK.

ELECTRICAL:
 CONTACT RATING, SILVER PLATED: 200mA @ 30V DC
 GOLD PLATED: 0.4VA @ 20V DC MAX,
 PER EIA-448, METHOD 6
 INITIAL CONTACT RESISTANCE, 20 MILLIOHMS MAX, PER EIA-364-23B, EACH POSITION
 INSULATION RESISTANCE, 100 MEGOHM MIN. PER EIA-364-21C EACH POSITION
 DIELECTRIC STRENGTH, 500 VOLT AC, PER EIA-364-20B, CONDITION 1, EACH POSITION.

MECHANICAL:
 ACTUATION FORCE, 200+/-100 GF
 ACTUATION TRAVEL, 2.0 MM
 LIFE EXPECTANCY, 10,000 CYCLES, PER EIA-448, METHOD 8 AND 9
 VIBRATION, PER EIA 364-28, CONDITION VII, LEVEL E
 MECHANICAL SHOCK, PER EIA-364-27, CONDITION A

ENVIRONMENTAL:
 OPERATING TEMPERATURE, -20 TO +70 DEGREES C, PER EIA 448, METHOD 10
 STORAGE TEMPERATURE, -25 TO +85 DEGREES C
 HUMIDITY AND TEMPERATURE CYCLING PER EIA-364-31B, METHOD III
 TEMPERATURE LIFE PER EIA-364-17B, METHOD B, TEMPERATURE TEST CONDITION 3, TIME CONDITION B
 THERMAL SHOCK, PER EIA-364-32C, -25 TO 85 DEGREES C
 SOLDERABILITY, PER EIA-364-52, CLASS 2, CATEGORY 1, 95% MINIMUM COVERAGE RESISTANCE TO
 SOLDER HEAT, PER 109-202, CONDITION B

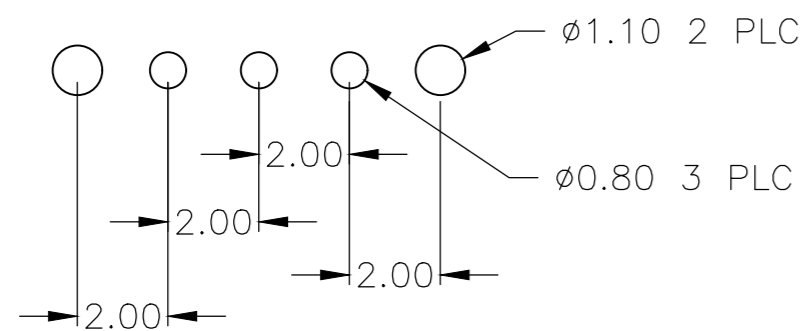
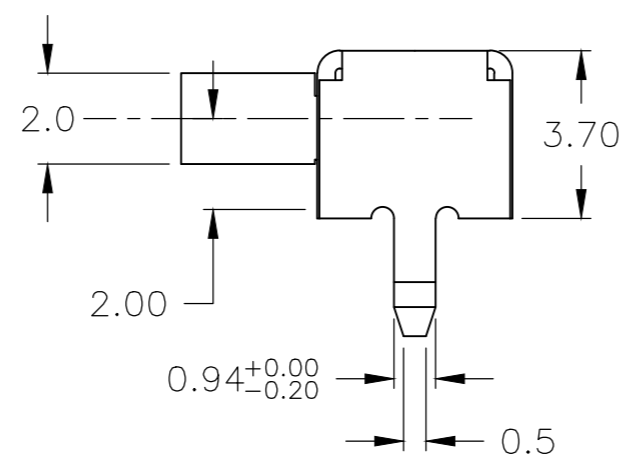
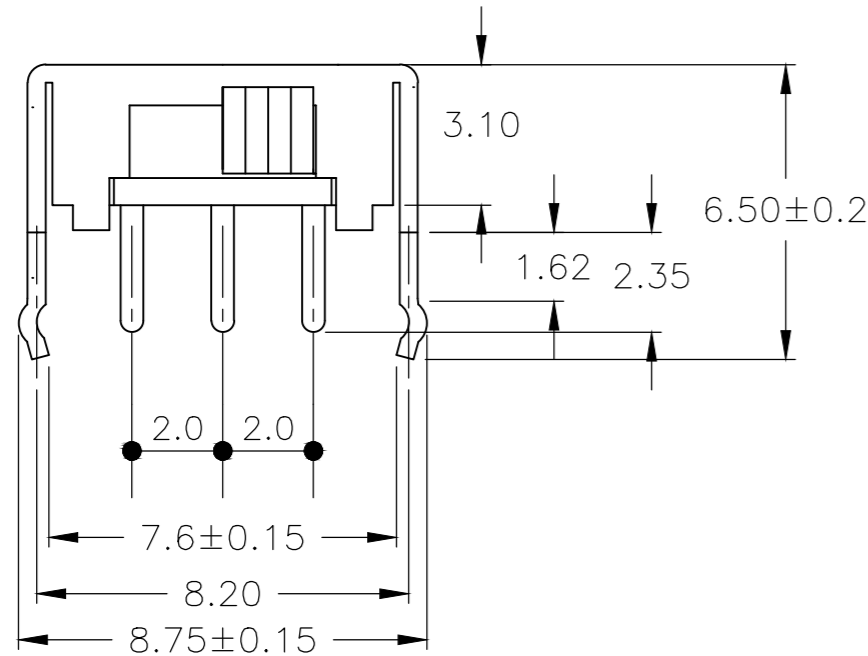
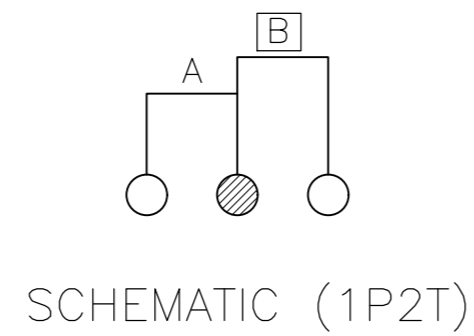
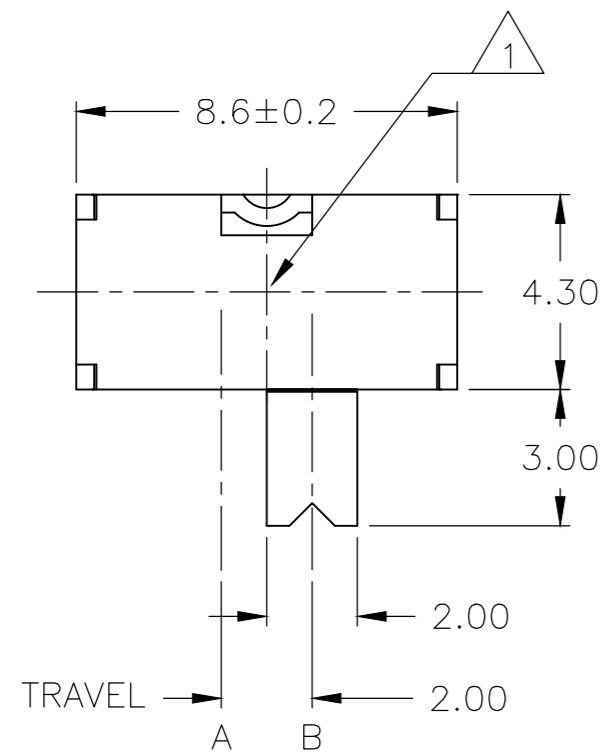

1 MARK PER 202-37,

2 ALL MATERIALS AND FINISHES SHALL COMPLY WITH EU DIRECTIVE 2002/95/EC OF 27JAN2003 (ROHS)".

PRELIMINARY	GOLD	1977391-2
	SILVER	1977391-1
	PLATING MATERIAL	PART NUMBER

THIS DRAWING IS A CONTROLLED DOCUMENT.		DWN M.BINNER 12JUN2008	TE Connectivity	
DIMENSIONS: mm		CHK M SARVER 12JUN08		
TOLERANCES UNLESS OTHERWISE SPECIFIED:		APVD M SARVER 12JUN08	NAME SLIDE SWITCH, RIGHT ANGLE	
0 PLC ± - 1 PLC ± - 2 PLC ± 0.2 3 PLC ± - 4 PLC ± - ANGLES ± -		PRODUCT SPEC	SIZE A2	
MATERIAL		APPLICATION SPEC	CAGE CODE 00779	DRAWING NO C=1977391
SEE NOTES		FINISH	WEIGHT -	RESTRICTED TO -
SEE NOTES		CUSTOMER DRAWING	SCALE 6:1	SHEET 1 of 1
			REV C3	