

Features

- 3535 High Power LED
- ROHS and REACH Compliant
- MSL3 qualified according to J-STD 020
- ESD 2KV

Applications

- Portable lighting
- Indoor/ Outdoor lighting
- Commercial lighting
- Industrial lighting

Description

The IN-C33(X)TL(X) is a high-power LED. It is a SMD type LED which can be used in various applications.

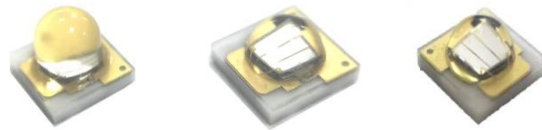

Outline		
60D	120D	90D
3.5x3.5x2.8	3.5x3.5x2.0	3.5x3.5x2.34
IN-C33BTL(X)	IN-C33CTL(X)	IN-C33ETL(X)

Recommended Solder Pattern

(Suggest Stencil $t=0.12$ mm)

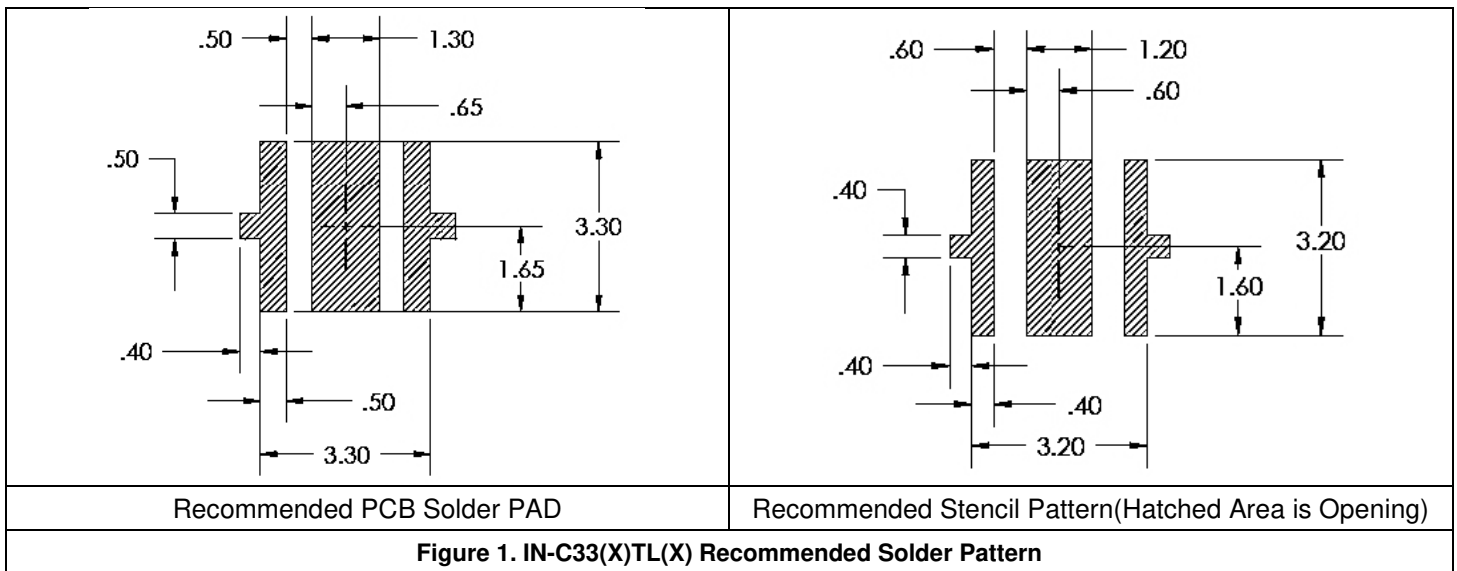

*Note: All dimensions are in mm, tolerance is ± 0.13 mm

Package Dimensions

(All dimensions are in mm, tolerance is $\pm 0.13\text{mm}$)

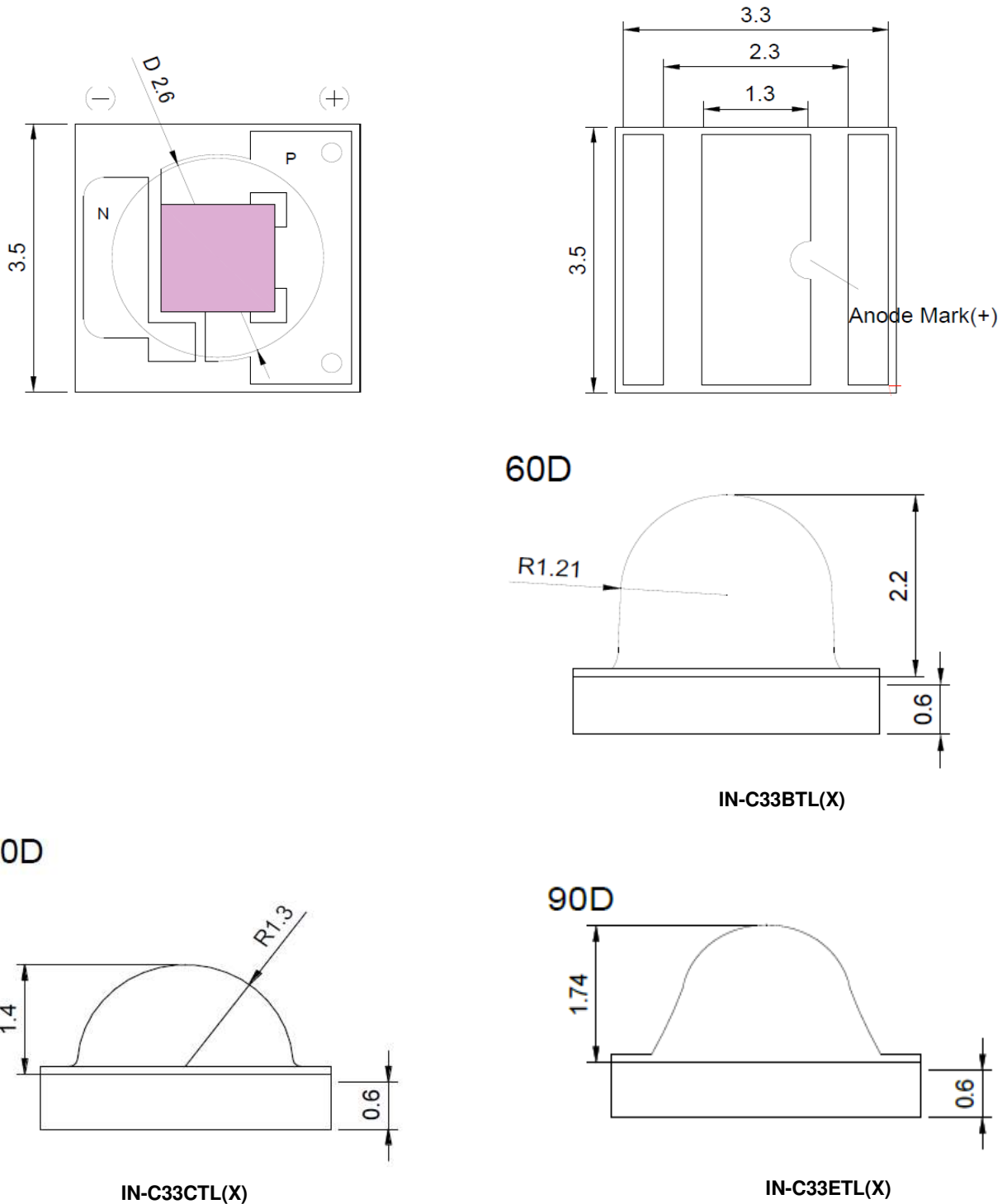

Figure 2. IN-C33(X)TL(X) Series Package Dimension

Absolute Maximum Rating(Ta=25°C)

Characteristics	Symbol	Min.	Typical	Max.	Unit
DC Forward Current ¹	I _F		350	700	mA
Pulse Forward Current ²	I _{PF}			1000	mA
Forward Voltage - Blue/Green/ Royal Blue	V _F	2.8		3.8	V
Forward Voltage - Red/ Yellow/ Amber/ Deep Red	V _F	1.4		2.8	V
Reverse Voltage	V _R		-5		V
Leakage Current (5V)	I _R			10	μA
Junction Temperature ³	T _j		115		°C
Storage Temperature Range	T _{stg}	-40	-	100	°C
Soldering Temperature	T _{sol}		260		°C
Thermal Resistance Junction / Solder Point	R _{th}	6	8	12	°C/W
Viewing Angle	2θ _{1/2}		60/90/120		Deg

Notes

1. For other ambient, limited setting of current will depend on de-rating curves.
2. D=0.01s duty 1/10.
3. When drive on maximum current , T_j must be kept below 115°C
4. Viewing angle(2θ_{1/2}) ±10°

ESD Precaution

ATTENTION: Electrostatic Discharge (ESD) protection



The symbol above denotes that ESD precaution is needed. ESD protection for GaP and AlGaAs based chips is necessary even though they are relatively safe in the presence of low static-electric discharge. Parts built with AlInGaP, GaN, or/and InGaN based chips are STATIC SENSITIVE devices. ESD precaution must be taken during design and assembly.

If manual work or processing is needed, please ensure the device is adequately protected from ESD during the process.

Please be advised that normal static precautions should be taken in the handling and assembly of this device to prevent damage or degradation which may be induced by electrostatic discharge (ESD).

Electronic-Optical Characteristics

Spectrum Distribution

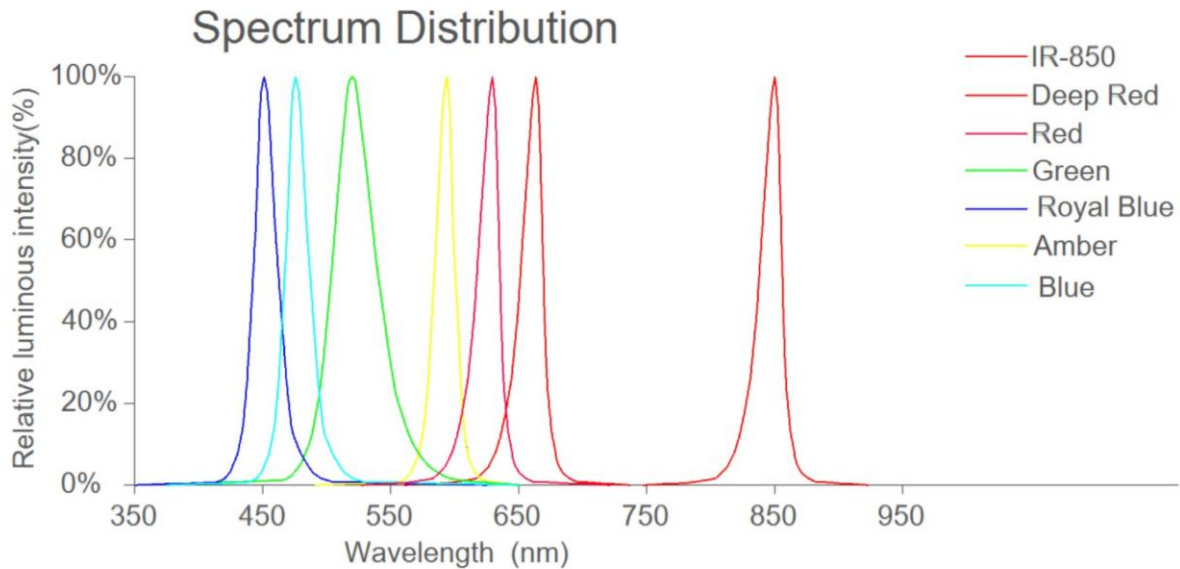
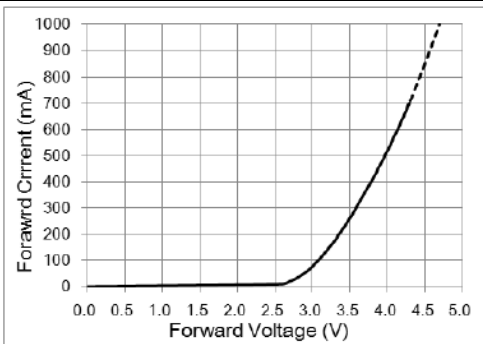
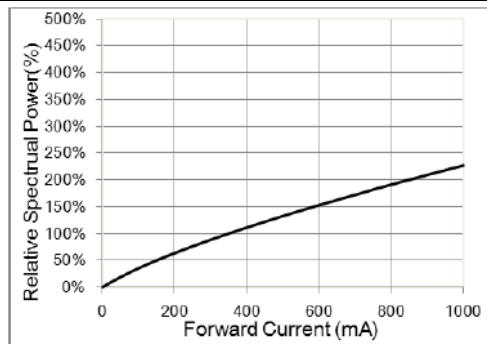
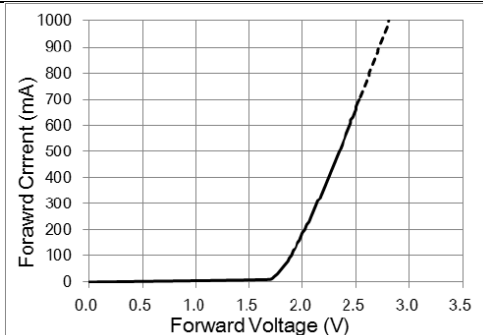
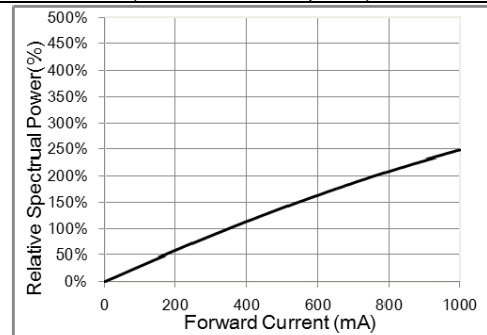
Forward Current VS. Forward Voltage ($T_a=25^{\circ}\text{C}$)
(Blue/ Green / Royal Blue)

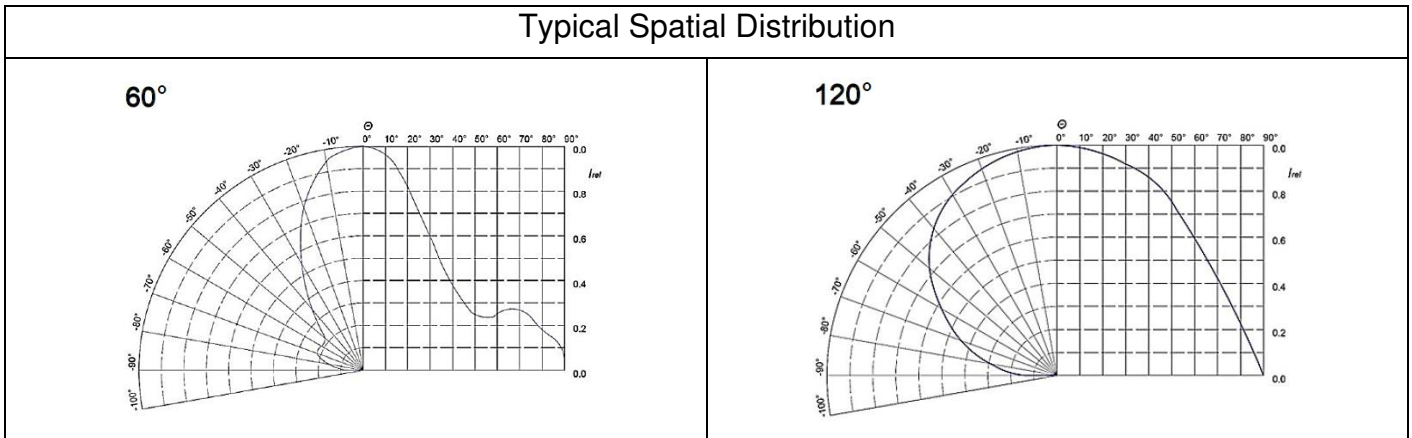
Relative luminous Flux vs. Forward Current ($T_a=25^{\circ}\text{C}$)
(Blue/ Green / Royal Blue)

Forward Current VS. Forward Voltage ($T_a=25^{\circ}\text{C}$)
(Red/ Yellow / Deep Red)

Relative luminous Flux vs. Forward Current ($T_a=25^{\circ}\text{C}$)
(Red/ Amber / Deep Red)

Typical Spatial Distribution

Product List

Part Number	Color	Luminous Flux (lm@350mA)		Wavelength (nm)	Forward Voltage (V)	
		Min	Max		Min	Max
IN-C33(X)TLB	Blue	25	35	460-470	2.8	3.6
IN-C33(X)TLG	Green	90	110	515-535	3.0	3.6
IN-C33(X)TLR	Red	40	60	620-630	1.8	2.6
IN-C33(X)TLY	Yellow	50	70	585-595	1.8	2.6
IN-C33(X)TLDR	Deep Red	15	30	650-670	1.4	2.6
IN-C33(X)TLRB	Royal Blue	15	30	450-460	2.8	3.6
IN-C33(X)TLA	Amber	45	75	600-610	1.8	2.8

Bin Code information
■ Forward Voltage Binning

Bin Code (@350mA)	Min. VF(V)	Max. VF(V)
V14	1.4	1.6
V16	1.6	1.8
V18	1.8	2.0
V20	2.0	2.2
V22	2.2	2.4
V24	2.4	2.6
V26	2.6	2.8
V28	2.8	3.0
V30	3.0	3.2
V32	3.2	3.4
V34	3.4	3.6
V36	3.6	3.8

Flux Binning

Color	Luminous Flux (lm@350mA)		
	Group	Min	Max
Blue	B15	15	20
	B20	20	25
	B25	25	30
Green	G80	80	90
	G90	90	100
	GH1	100	110
Red	R40	40	45
	R45	45	50
	R50	50	55
	R55	55	60
Yellow	Y50	50	55
	Y55	55	60
	Y60	60	65
	Y65	65	70
Deep Red	R15	15	20
	R20	20	25
	R25	25	30
Royal Blue	B15	15	20
	B20	20	25
	B25	25	30
Amber	A45	45	50
	A50	50	55
	A55	55	60
	A60	60	65
	A65	65	70
	A70	70	75

Note:

1. Tolerance of luminous flux (Φ_v) $\pm 5\%$.

■ Wavelength Binning

Color	Wavelength (Wd nm@350mA)		
	Group	Min	Max
Blue	B1	460	465
	B2	465	470
Green	G1	515	520
	G2	520	525
	G3	525	530
	G4	530	535
Red	R1	620	625
	R2	625	630
Yellow	Y1	585	590
	Y2	590	595
Deep Red	DR1	650	660
	DR2	660	670
Royal Blue	RB1	450	455
	RB2	455	460
Amber	A1	600	605
	A2	605	610

Note:

1. Tolerance of Wavelength \pm nm.
2. Wavelength of Deep Red is meaning peak wavelength only.

Ordering Information

Orderable Part Number	Color	Angle	Luminous Flux (lm@350mA)		Wavelength (nm)	Forward Voltage (V)	
			Min	Max		Min	Max
IN-C33BTLB	Blue	60	25	35	460-470	2.8	3.6
IN-C33ETLB		90	25	35	460-470	2.8	3.6
IN-C33CTLB		120	25	35	460-470	2.8	3.6
IN-C33BTLG	Green	60	90	110	515-535	3.0	3.6
IN-C33ETLG		90	90	110	515-535	3.0	3.6
IN-C33CTLG		120	90	110	515-535	3.0	3.6
IN-C33BTLR	Red	60	40	60	620-630	1.8	2.6
IN-C33ETLR		90	40	60	620-630	1.8	2.6
IN-C33CTLR		120	40	60	620-630	1.8	2.6
IN-C33BTLY	Yellow	60	50	70	585-595	1.8	2.6
IN-C33ETLY		90	50	70	585-595	1.8	2.6
IN-C33CTLY		120	50	70	585-595	1.8	2.6
IN-C33BTLDR	Deep Red	60	15	30	650-670	1.4	2.6
IN-C33ETLDR		90	15	30	650-670	1.4	2.6
IN-C33CTLDR		120	15	30	650-670	1.4	2.6
IN-C33BTLRB	Royal Blue	60	15	30	450-460	2.8	3.6
IN-C33ETLRB		90	15	30	450-460	2.8	3.6
IN-C33CTLRB		120	15	30	450-460	2.8	3.6
IN-C33BTLA	Amber	60	45	75	600-610	1.8	2.8
IN-C33ETLA		90	45	75	600-610	1.8	2.8
IN-C33CTLA		120	45	75	600-610	1.8	2.8

Label Specifications

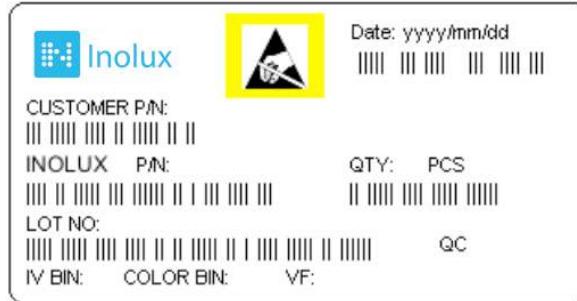

Inolux P/N:

I	N	-	C	3	3	(X)	T	L		(X)	-	X	X	X	X
			Material	Package		Variation	Orientation	Current	Lens	Color		Customized Stamp-off			
Inolux	SMD		C = Ceramic Type	33B = 3.5 x 3.5, 60 Deg. 33C = 3.5 x 3.5, 120 Deg. 33E = 3.5 x 3.5, 90 Deg.			T = Top Mount	L = 350mA	(Blank) = Clear	B = 470nm G = 520nm R = 630nm Y = 590nm DR = 660nm RB = 450nm A = 605nm					

Lot No.:

Z	2	0	1	7	01	24	001
Internal Tracker	Year (2017, 2018,)				Month	Date	Serial

Reflow Soldering

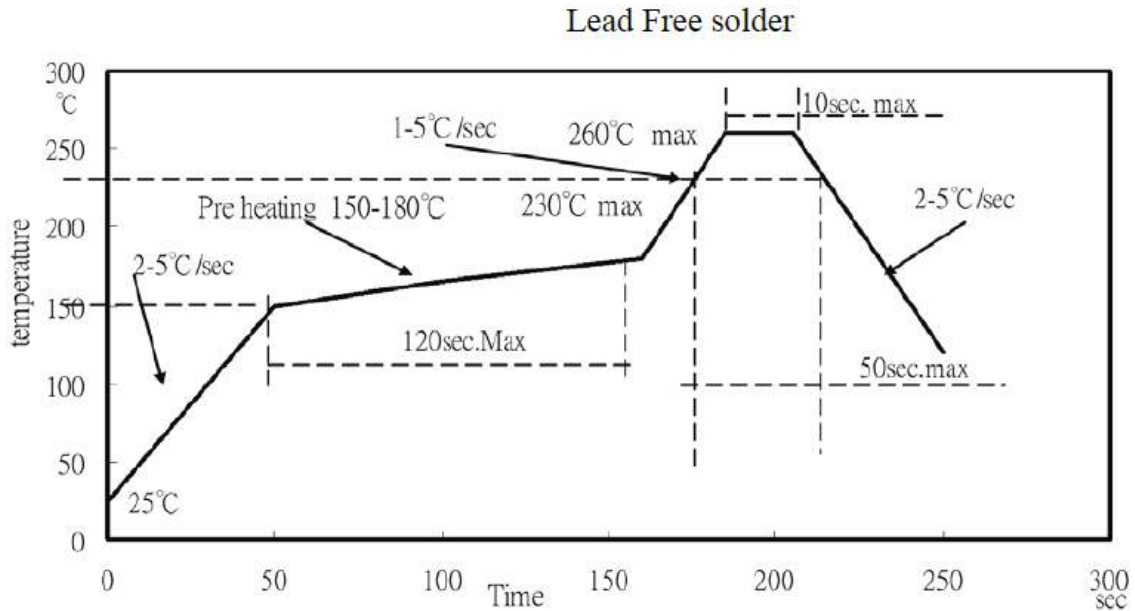

Soldering Iron

Basic Spec is ≤ 4 sec. when 260°C (+10°C \rightarrow -1 second). Power dissipation of Iron should be less than 15W. Surface temperature should be under 230°C

Rework

Rework should be completed within 4 second under 245°C

Notes

1. Do not stress the silicone resin while it is exposed to high temperature.
2. The number of reflow process should not exceed 3 times.

Packing

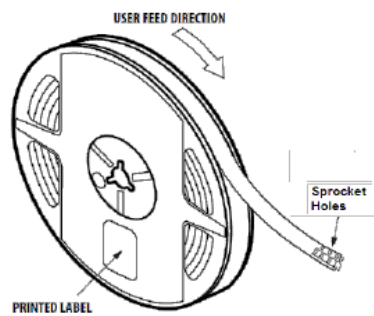
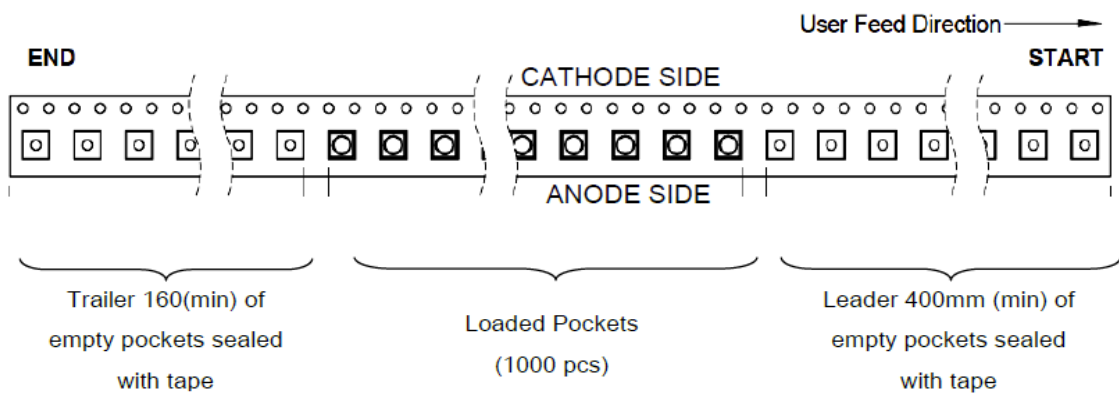
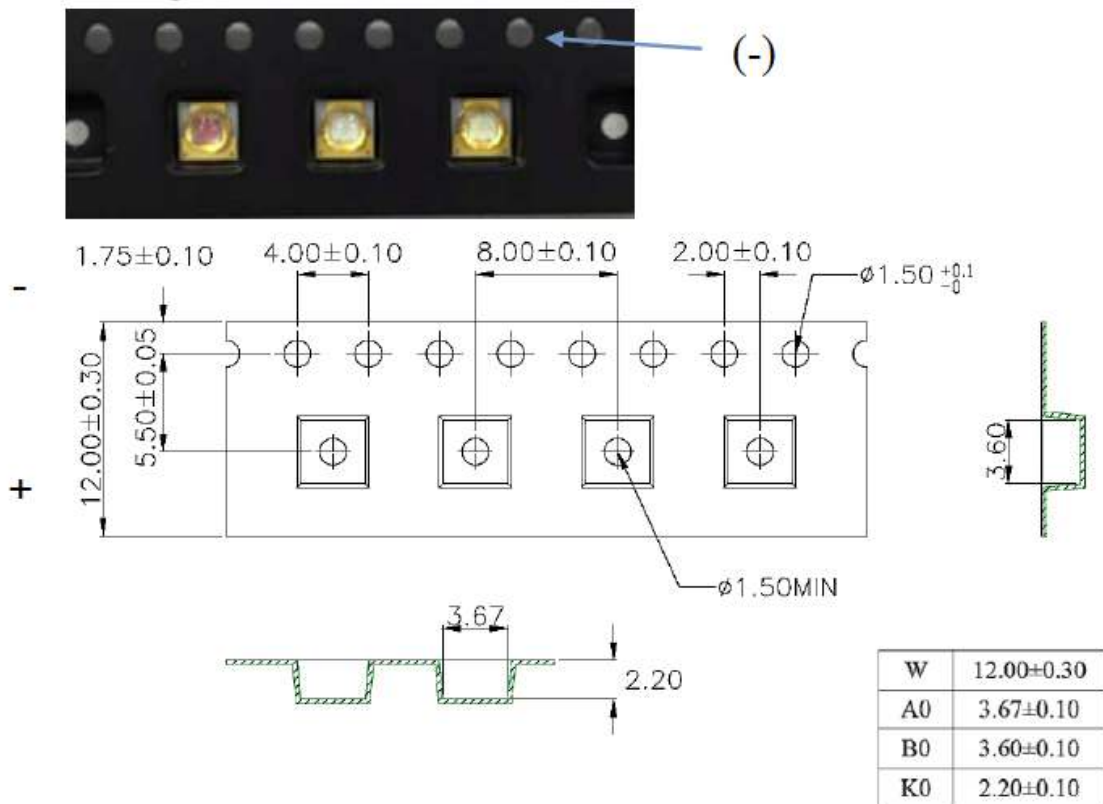

Unpackaged Reel

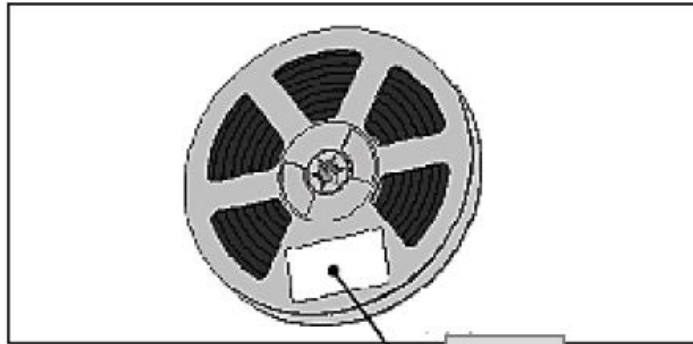

Label

Packaged Reel

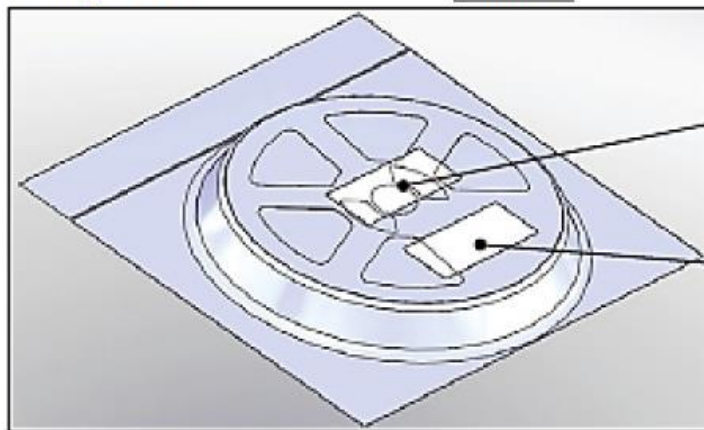

Label

Label

Notes:

1. Each Reel (minimum number of pieces is 100 and maximum is 500 (60D)/1000 (120D) is packed in a moisture-proof bag along with 2 packs of desiccant and a humidity indicator card;
2. A maximum of 5 moisture-proof bags are packed in an inner box (size: 240mm x 200mm x 105mm \pm 5mm)
3. A maximum of 4 inner boxes are put in an outer box (size: 410mm x 255mm x 230mm \pm 5mm)
4. Part No., Lot No., quantity should be indicated on the label of the moisture-proof bag and the cardboard box.

Precautions

1. Recommendation for using LEDs

1.1 The lens of LEDs should not be exposed to dust or debris. Excessive dust and debris may cause a drastic decrease in the luminosity.

1.2 Avoid mechanical stress on LED lens.

1.3 Do not touch the LED lens surface. It would affect the optical performance of the LED due to the LED lens' damage.

1.4 Pick & place tools are recommended for the remove of LEDs from the factory tape & reel packaging

2. Pick & place nozzle

The pickup tool was recommended and shown as below

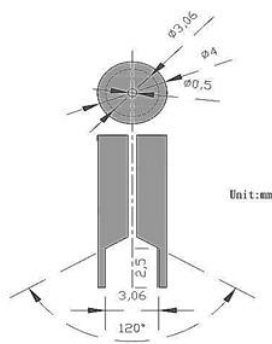

3. Lens handling

Please follow the guideline to pick LEDs

3.1 Use tweezers to pick LEDs

3.2 Do not touch the lens by using tweezers

3.3 Do not touch lens with fingers

3.4 Do not apply more than 4N of lens (400g) directly onto the lens

4. Lens cleaning

In the case which a small amount of dirt and dust particles remain on the lens surface, a suitable cleaning solution can be applied.

4.1 Try a gentle wiping with dust-free cloth

4.2 If needed, use dust-free cloth and isopropyl alcohol to gently clean the dirt from the lens surface.

4.3 Do not use other solvents as they may directly react with the LED assembly

4.4 Do not use ultrasonic cleaning which will damage the LEDs

Test Items and Results of Reliability

Test Item	Test Conditions	Duration/ Cycle	Number of Damage	Reference
Thermal Shock	-40°C 30min ↑↓5min 125°C 30min	100 cycles	0/22	AECQ101
High Temperature Storage	Ta=100°C	1000 hrs	0/22	EIAJ ED-4701 200 201
Humidity Heat Storage	Ta=85°C RH=85%	1000 hrs	0/22	EIAJ ED-4701 100 103
Low Temperature Storage	Ta=-40°C	1000 hrs	0/22	EIAJ ED-4701 200 202
Life Test	Ta=25°C If=350mA	1000 hrs	0/22	Tested with Inolux standard
High Humidity Heat Life Test	85°C RH=85% If=350mA	1000 hrs	0/22	Tested with Inolux standard
High Temperature Life Test	Ta=85°C	1000 hrs	0/22	Tested with Inolux standard
ESD(HBM)	2KV at 1.5kΩ;100pf	3 Times	0/22	MIL-STD-883

Criteria for Judging the Damage				
Item	Symbol	Condition	Criteria for Judgment	
			Min	Max
Forward Voltage	V _F	If=350mA	-	USL ¹ ×1.1
Reverse Current	I _R	VR =5V	-	100μA
Luminous Intensity	I _v	If=350mA	LSL ² ×0.7	-

Notes:

1. USL: Upper specification level
2. LSL: Lower specification level

Revision History

Changes since last revision	Page	Version No.	Revision Date
Initial Release		1.0	04-17-2018
Revise Format		1.1	10-18-2018
Revise the Drawing	4	1.2	06-19-2021

DISCLAIMER

INOLUX reserves the right to make changes without further notice to any products herein to improve reliability, function or design. INOLUX does not assume any liability arising out of the application or use of any product or circuit described herein; neither does it convey any license under its patent rights, nor the rights of others.

LIFE SUPPORT POLICY

INOLUX's products are not authorized for use as critical components in life support devices or systems without the express written approval of the President of INOLUX or INOLUX CORPORATION. As used herein:

1. Life support devices or systems are devices or systems which, (a) are intended for surgical implant into the body, or (b) support or sustain life, and (c) whose failure to perform when properly used in accordance with instructions for use provided in the labeling, can be reasonably expected to result in a significant injury of the user.
2. A critical component in any component of a life support device or system whose failure to perform can be reasonably expected to cause the failure of the life support device or system, or to affect its safety or effectiveness.