

Transfer or duplication of this document as well as the utilisation or communication of its content are not permitted unless express consent is granted. Violations give rise to claims for damages. All rights reserved in case of patent, utility model or design patent registrations.

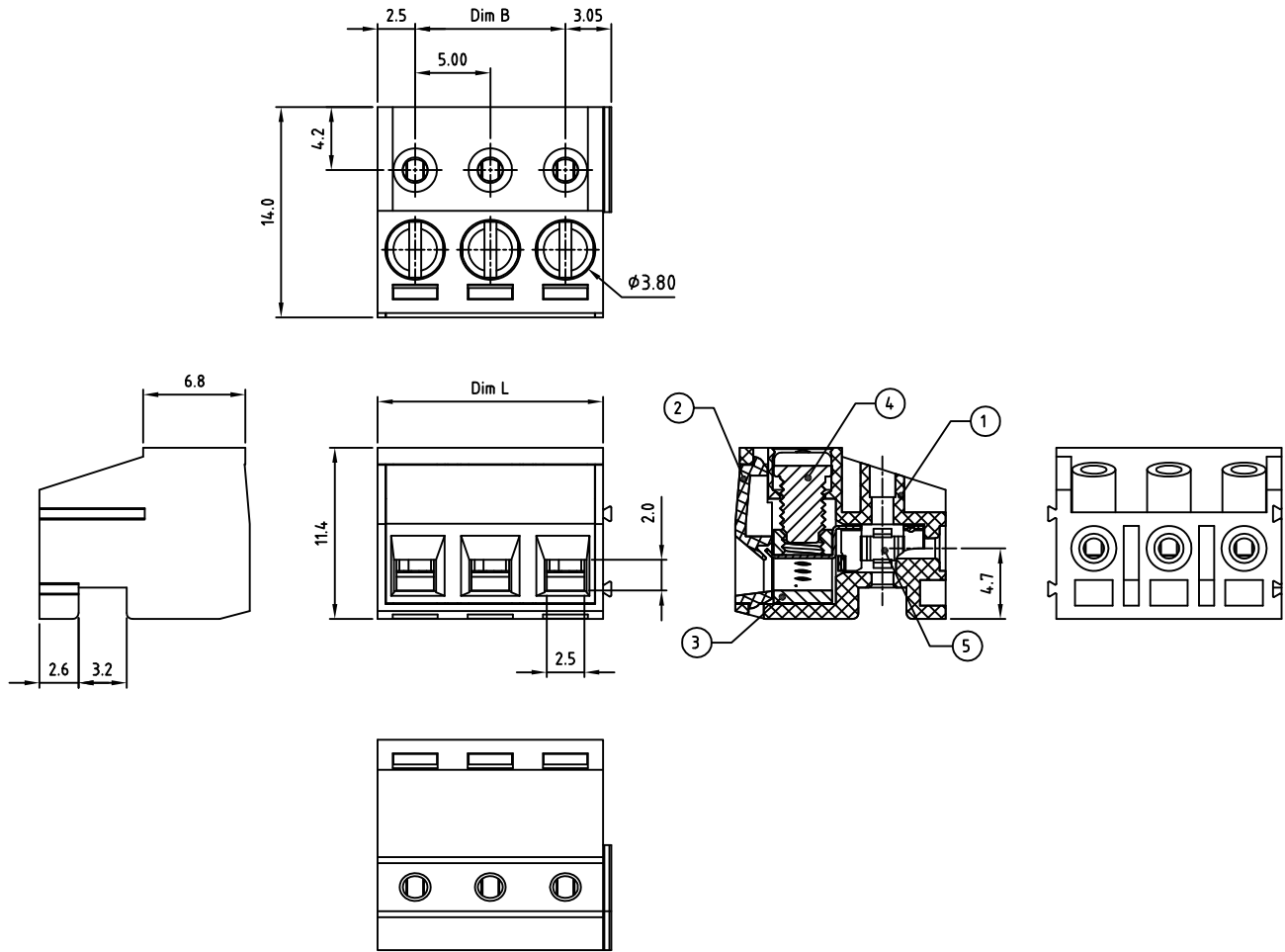

Technical data

1. Nominal voltage: 300V/10A
PITCH: 5.0mm
2. Connection capacity:
AWG 26-16
3. Insulation Withstanding Voltage:
AC 1600V/MIN
4. Insulation Resistance:
1000MΩ or more at DC500V
5. Tightening torque:
4.0kgf.cm (0.4N.m)
6. Screw thread: M3
7. Stripping length: 5.0-6.0mm
8. Operating temperature range: -40°C ~ 115°C
9. Undimensioned Tolerances:

Dim.L=P×5.0		
Dim.B=(P-1)×5.0		
P= number of poles(2-24P)		
0-30mm	Dim B	Dim L
over 30mm-60mm	±0.15	±0.20
over 60mm-90mm	±0.20	±0.25
over 90mm	±0.25	±0.30
	±0.30	±0.40

10. Safety approval:
11. RoHS Compliance

Part No.: OSTTTXX0100

No. of Poles	COLOR
02 2 Poles	0: Black (Standard)
03 3 Poles	2: Red
...	3: Orange
24 24 Poles	4: Yellow
	5: Green
Nonstandard colors	6: Blue
Mins could apply	8: Grey

5	WIRE GUARD	PhBz(t=0.20mm),	Tin plated	P
4	SCREW	STEEL	M3×0.5, Zn Plated	P
3	CAGE	BRASS	M3×0.5, Tin PLATED	P
2	COVER	PA66 UL94V-0	ALL COLOR	1
1	BODY	PA66 UL94V-0	ALL COLOR	1
ITEM	NAME OF PART	MATERIAL	NOTES	Q'TY
DWG.	WF. Zhang	DATE 2015.11.15	UNITS: MM SHEET: 1 OF 1	Tolerance
CHK.	WF. Zhang	DATE 2016.06.14	SCALE: NONE 3:1 (:)	REV.: A
APP.		DATE	TITLE: OSTTT 5.0 Series Stackable type " " slot screw	X. ±0.50 X.X ±0.30 X.XX ±0.10 X* ±1°
			PART NO. OSTTTXX0100	
			DWG NO. OSTTTXX0100.dwg	

△	DESCRIPTION	CHK.	DATE



ON-SHORE TECHNOLOGY, INC.