

# Ceramic PTC Thermistor: PPL Series

## Dip Type for Telecom Application



### ■ Features

1. RoHS compliant
2. Radial leaded devices
3. Wide resistance range in telecom area from 7 to 50Ω
4. Compliant with ITU-T standards
5. Operating temperature range:  
0 ~ +60°C (V=Vmax)  
-25 ~+125°C (V=0)
6. Agency Recognition:  
UL/cUL File No.: E138827  
TUV File No.: R 50171789



### ■ Recommended Applications

1. Cable Modem, ADSL Modem with VoIP
2. Customer Premise Equipment (CPE)
3. Central Office (CO)
4. Access Equipment (AE)
5. Main Distribution Frame (MDF)
6. Public Switched Telephone Network (PSTN)
7. Exchanger

### ■ Part Number Code

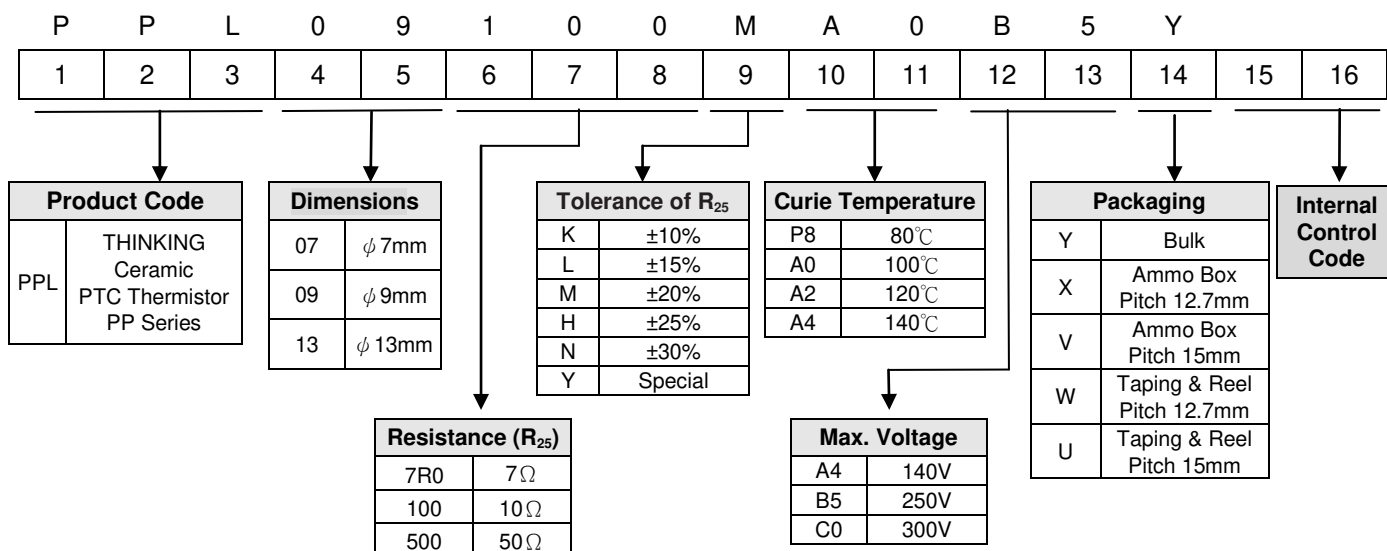

# Ceramic PTC Thermistor: PPL Series

## Dip Type for Telecom Application



### ■ Structure and Dimensions

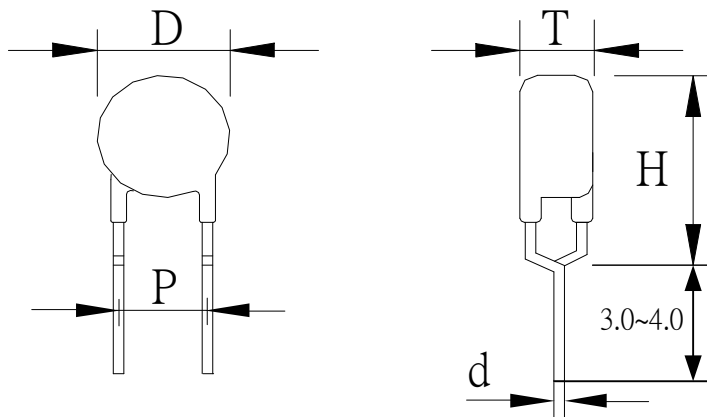

(Unit: mm)

Part No.	D	T	H	d	P
	Max.	Max.	Max.	±0.02	±1.0
PPL077R0□A0B5	6.5-9.0	3.0-5.0	13.5	0.6	5
PPL137R0□A0B5	12.5-15.0	3.0-5.0	18.5	0.6	5
PPL07100□A0B5	6.5-9.0	3.0-5.0	13.5	0.6	5
PPL09100□A0B5	8.0-10.5	3.0-5.0	15.5	0.6	5
PPL07180□A0B5	6.5-9.0	3.0-5.0	12.5	0.6	5
PPL09180□A0B5	8.0-10.5	3.0-5.0	14.5	0.6	5
PPL07250□A0B5	6.5-9.0	3.0-5.0	12.5	0.6	5
PPL09250□A0B5	8.0-10.5	3.0-5.0	14.5	0.6	5
PPL07390□A0B5	6.5-9.0	3.0-5.0	12.5	0.6	5
PPL09390□A0B5	8.0-10.5	3.0-5.0	14.5	0.6	5
PPL07500□A0C0	6.5-9.0	3.0-5.0	12.5	0.6	5
PPL09500□A0C0	8.0-10.5	3.0-5.0	14.5	0.6	5

# Ceramic PTC Thermistor: PPL Series

## Dip Type for Telecom Application



### ■ Characteristics

Part No.	Zero-power Resistance at 25°C	Non-operating Current at 25°C	Non-operating Current at 40°C	Trip Current at 25°C	Responding Time (sec)			Max. Voltage	Max. Current	Withstanding Voltage	Safety Approvals	
	R <sub>25</sub> (Ω)	I <sub>N</sub> (mA) @25°C	I <sub>N</sub> (mA) @40°C	I <sub>T</sub> (mA) @25°C	T(3A→0.5A)	T(1A→0.5A)	T(0.5A→0.15A)	V <sub>max</sub> (V <sub>ac</sub> )	I <sub>max</sub> (A)	V <sub>w</sub> (V <sub>ac</sub> )	UL/cUL	TUV
PPL077R0□A0B5	7	150	130	400	0.4	3	25	250	2.5	250	√	√
PPL137R0□A0B5	7	180	170	540	3	20	90	250	3	250	√	√
PPL07100□A0B5	10	130	120	390	0.8	8.0	35	250	2.5	250	√	√
PPL09100□A0B5	10	140	130	390	0.8	8.0	35	250	3	250	√	√
PPL07180□A0B5	18	110	100	330	0.4	2.5	10	250	3	250	√	√
PPL09180□A0B5	18	110	100	330	0.4	2.5	10	250	3	250	√	√
PPL07250□A0B5	25	90	80	225	0.35	2.0	10	250	3	250	√	√
PPL09250□A0B5	25	75	70	225	0.35	2.0	10	250	3	250	√	√
PPL07390□A0B5	39	70	65	180	0.3	1.0	4.0	250	3	250	√	√
PPL09390□A0B5	39	70	65	180	0.3	1.0	4.0	250	3	250	√	√
PPL07500□A0C0	50	60	55	165	0.15	0.8	3.5	300	3	600	√	√
PPL09500□A0C0	50	65	60	165	0.15	0.8	3.5	300	3	650	√	√

Note: □ is tolerance of R<sub>25</sub>.

# Ceramic PTC Thermistor: PPL Series

## Dip Type for Telecom Application



### ■ R-T Characteristic Curves (Typical)

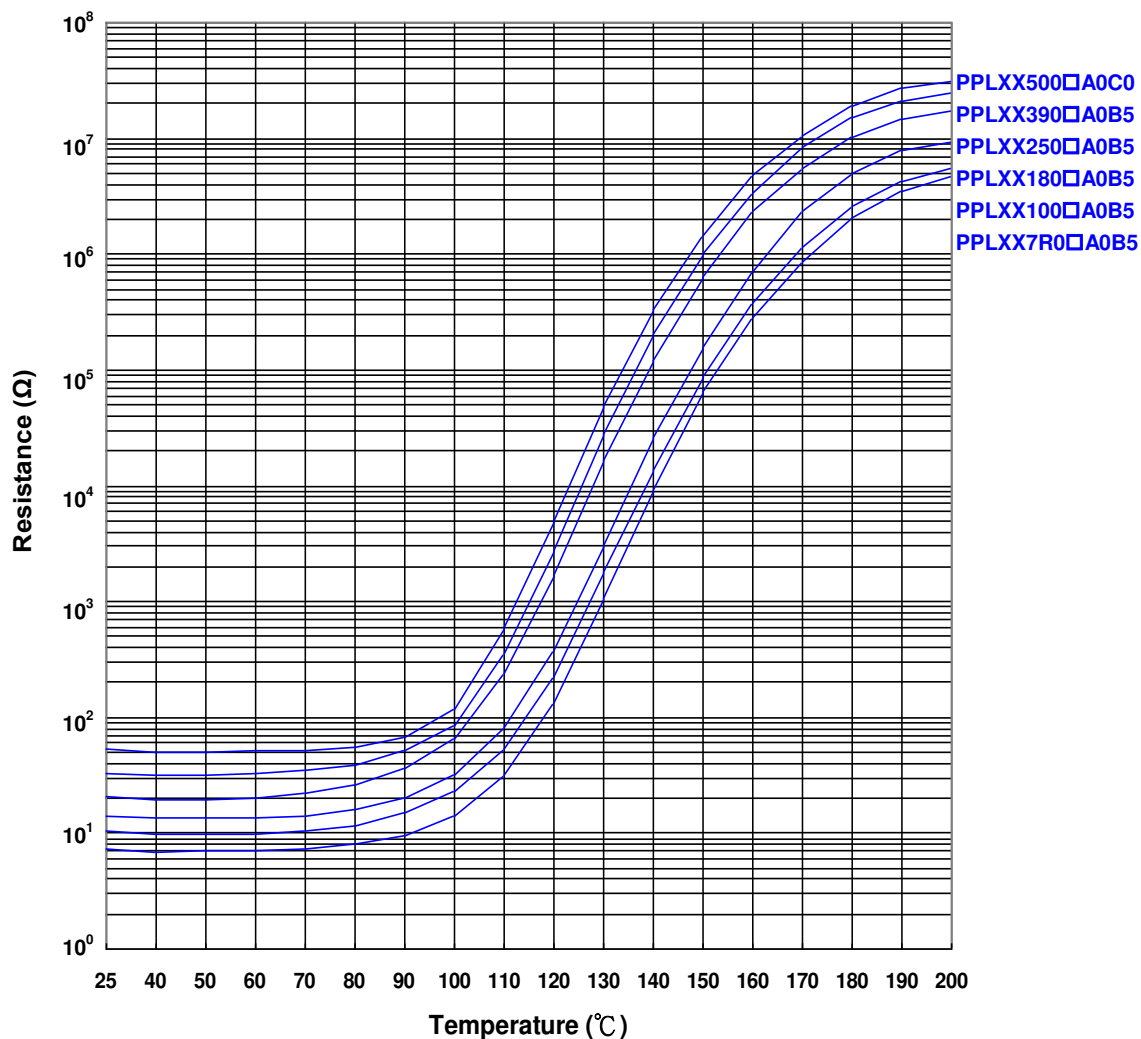

### ■ Circuit for Typical Application

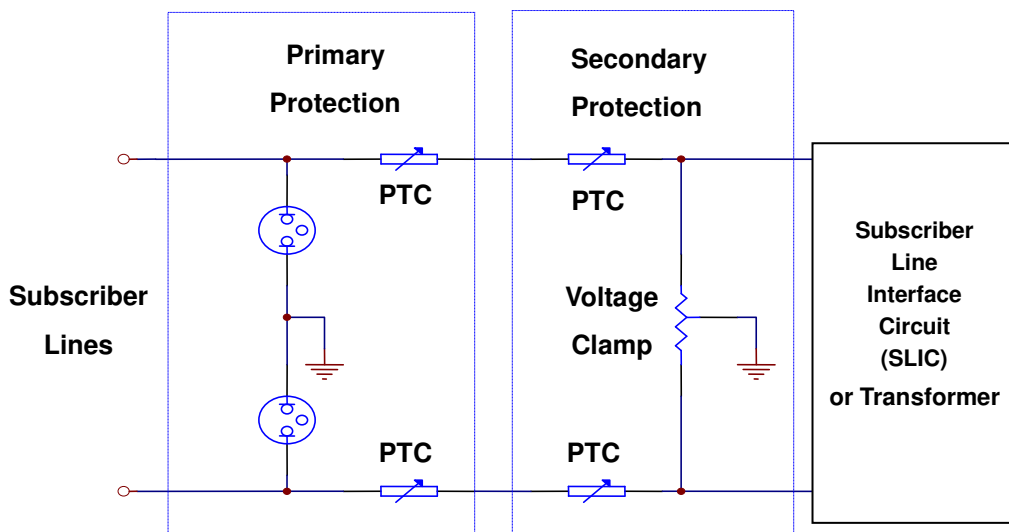

# Ceramic PTC Thermistor: PPL Series

## Dip Type for Telecom Application



### ■ Soldering Recommendation

#### ● Wave Soldering Profile

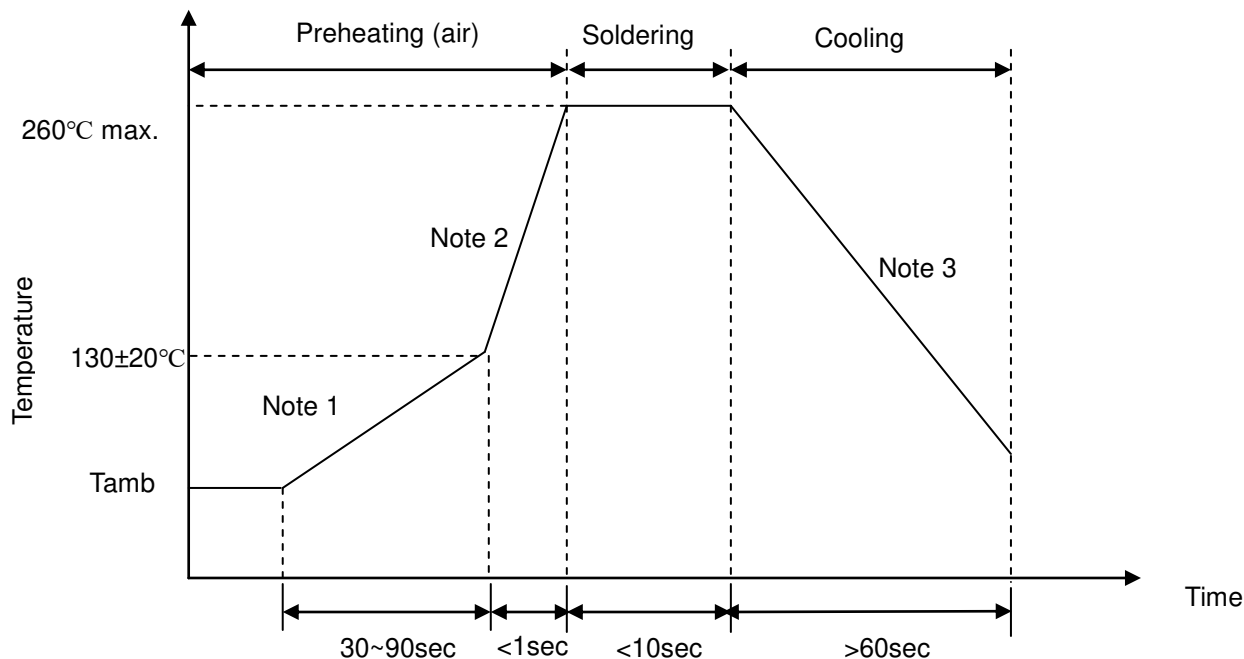

#### Note

1. (1~3)°C/sec.
2. Approx. 20 0°C/sec
3. 5°C/sec Max

#### ● Recommended Reworking Conditions with Soldering Iron

Item	Conditions
Temperature of Soldering Iron-tip	360°C (max.)
Soldering Time	3 sec (max.)
Distance from coating	2 mm (min.)

# Ceramic PTC Thermistor: PPL Series

## Dip Type for Telecom Application



### ■ Reliability

Item	Standard	Test conditions and methods	Specifications															
Robustness of Terminations	IEC 60738-1	Gradually apply 10N and keep the unit fixed for 10±1 sec.	$ \Delta R_{25}/R_{25}  \leq 20\%$ No visible damage															
Solderability	IEC 60738-1	245±3 °C, 2±0.5 sec	At least 95% of terminal electrode is covered by new solder															
Resistance to Soldering Heat	IEC 60738-1	260±3 °C, 10±1 sec	$ \Delta R_{25}/R_{25}  \leq 20\%$ No visible damage															
Vibration	IEC 60738-1	Frequency range:10~55Hz Amplitude: 0.75mm or 98m/s <sup>2</sup> Direction: 3 mutually perpendicular directions Duration: 6hrs (3x2 hrs)	$ \Delta R_{25}/R_{25}  \leq 20\%$ No visible damage															
Shock	IEC 60738-1	Wave: half-sine ΔV: 1.0m/s Acceleration: 50 m/s <sup>2</sup> Pulse time: 30ms	$ \Delta R_{25}/R_{25}  \leq 20\%$ No visible damage															
Rapid Change of Temperature	IEC 60738-1	The thermal shock conditions shown below shall be repeated 5 cycles. <table border="1" style="margin-left: auto; margin-right: auto;"> <thead> <tr> <th>Step</th> <th>Temperature (°C)</th> <th>Period (minutes)</th> </tr> </thead> <tbody> <tr> <td>1</td> <td>-40 ± 5</td> <td>30 ± 3</td> </tr> <tr> <td>2</td> <td>Room temperature</td> <td>5 ± 3</td> </tr> <tr> <td>3</td> <td>85 ± 5</td> <td>30 ± 3</td> </tr> <tr> <td>4</td> <td>Room temperature</td> <td>5 ± 3</td> </tr> </tbody> </table>	Step	Temperature (°C)	Period (minutes)	1	-40 ± 5	30 ± 3	2	Room temperature	5 ± 3	3	85 ± 5	30 ± 3	4	Room temperature	5 ± 3	$ \Delta R_{25}/R_{25}  \leq 20\%$ No visible damage
Step	Temperature (°C)	Period (minutes)																
1	-40 ± 5	30 ± 3																
2	Room temperature	5 ± 3																
3	85 ± 5	30 ± 3																
4	Room temperature	5 ± 3																
Climatic Sequence	IEC 60738-1	Dry heat: 125 °C for 16 hrs Damp heat first cycle:40°C , 95% R.H ,cycle time: 24 hrs Cold: -40°C for 2 hrs Damp heat (cyclic), remaining cycles: 5 cycles Test according to IEC60068-2-30	$ \Delta R_{25}/R_{25}  \leq 20\%$ No visible damage															
Damp Heat, Steady State	IEC 60738-1	40±2°C, 90~95% RH, for 1000±2hrs	$ \Delta R_{25}/R_{25}  \leq 20\%$ No visible damage															
Endurance at Max. Operating Temp. and Max. Voltage	IEC 60738-1	60°C, Vmax, It<l<Imax for 1000±2hrs	$ \Delta R_{25}/R_{25}  \leq 20\%$ No visible damage															
Over Current	Specification Standard	220Vrms, Imax, 60s on and 600s off , 20 cycles (For Vw ≤ 250V only)	$ \Delta R_{25}/R_{25}  \leq 20\%$ No visible damage															
Power Contact	ITU-T K.20 9.4	230Vrms,10Ω, 15 Min.	No visible damage															
Lightning Surge	ITU-T K30 4.2.5	1.0KV, 10/1000μs,25A, 30 cycles 1.5KV, 10/310μs,37.5A, 10cycles	$ \Delta R_{25}/R_{25}  \leq 20\%$ No visible damage															
Power Induction	Specification Standard	650Vrms,600Ω,1s on and 60s off ,10 cycles(For Vw ≥ 650V only) 600Vrms,600Ω,1s on and 60s off ,10 cycles(For Vw=600V only)	$ \Delta R_{25}/R_{25}  \leq 10\%$ No visible damage															
Failure Mode	Specification Standard	600Vrms,0ohm,1hr ,1 cycle(For Vw ≥ 650V only) 250 Vrms,10A,1hr ,1 cycle(For Vw < 650V only)	Circuit disconnected or high resistance is allowed ,but low resistance or fire is not allowed.															

# Ceramic PTC Thermistor: PPL Series

## Dip Type for Telecom Application



### ■ Packaging

#### ● Taping Specification

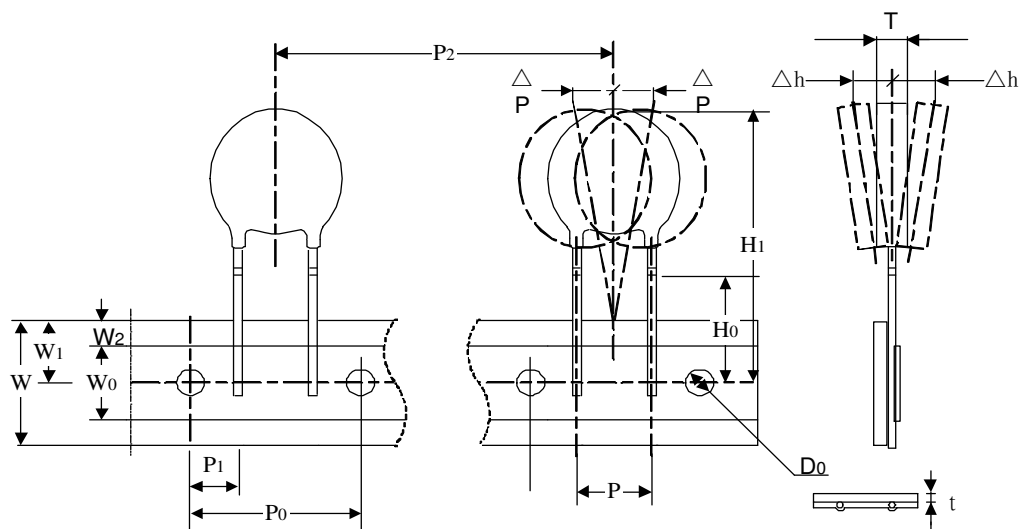

#### ● Parameter List

(Unit: mm)

Index	Parameter	Nominal dimensions		Tolerance
P	Lead spacing	5		±1
P <sub>0</sub>	Sprocket hole pitch	12.7	15	±0.3
P <sub>1</sub>	Ordinate to adjacent component lead	3.85	5	±1
P <sub>2</sub>	Device pitch	12.7	15.0	±1
H <sub>0</sub>	Abscissa to plane (kinked lead)	16	16	±0.5
H <sub>1</sub>	Abscissa to top	29 ( for PPL07 series) 31 ( for PPL09 series) 35 ( for PPL13 series)		Max.
W	Carrier tape width	18	18	±1
W <sub>0</sub>	Hold-down tape width	12	12	±1.5
W <sub>1</sub>	Sprocket hole position	9	9	±1
W <sub>2</sub>	Top distance between tape edges	3	3	Max.
ΔP	Body tape plane deviation	1	1	Max.
Δh	Body lateral deviation	2	2	Max.
D <sub>0</sub>	Sprocket hole diameter	4	4	±0.2
t	Tape thickness	0.6	0.6	±0.2

# Ceramic PTC Thermistor: PPL Series

## Dip Type for Telecom Application



### ■ Quantity

#### ● Bulk Packing

Disc Size (mm)	Quantity (pcs/bag)
$\Phi \leq 10$	200
$10 < \Phi < 20$	100

#### ● Reel Packing

Disc Size (mm)	Quantity (pcs/reel)
$\Phi \leq 7$	1,500
$07 < \Phi \leq 12$	1,000
$12 < \Phi \leq 16$	750

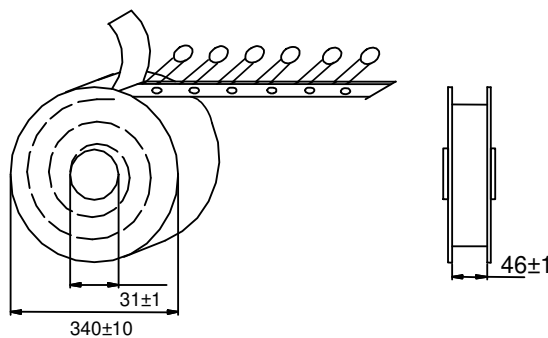

(Unit: mm)

#### ● Ammo Packing

Disc Size (mm)	Quantity (pcs/box)
$\Phi \leq 7$	1,000
$07 < \Phi \leq 12$	750
$12 < \Phi \leq 16$	500

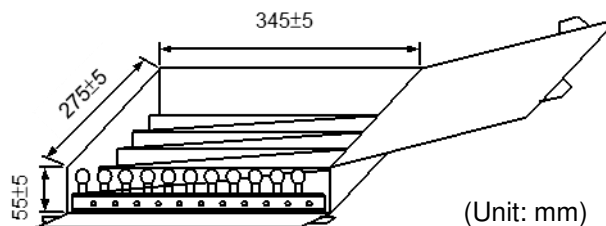

(Unit: mm)

### ■ Warehouse Storage Conditions of Products

#### ● Storage Conditions :

1. Storage Temperature:  $-10^{\circ}\text{C} \sim +40^{\circ}\text{C}$
2. Relative Humidity:  $\leq 75\% \text{RH}$
3. Keep away from corrosive atmosphere and sunlight.

#### ● Period of Storage : 1 year

### ■ Usage

Please keep products away from the conditions mentioned below to avoid their characteristic deterioration and failure.

1. Corrosive gas or deoxidizing gas ( $\text{Cl}_2$ ,  $\text{H}_2\text{S}$ ,  $\text{NH}_3$ ,  $\text{SO}_x$ ,  $\text{NO}_x$  etc.)
2. Place in a vacuum or put pressure
3. Salt water, oil, solvent and chemical liquid
4. Flammable gas
5. Place in splashed water, or high humidity and dewing place
6. Other places similar to any conditions mentioned above