

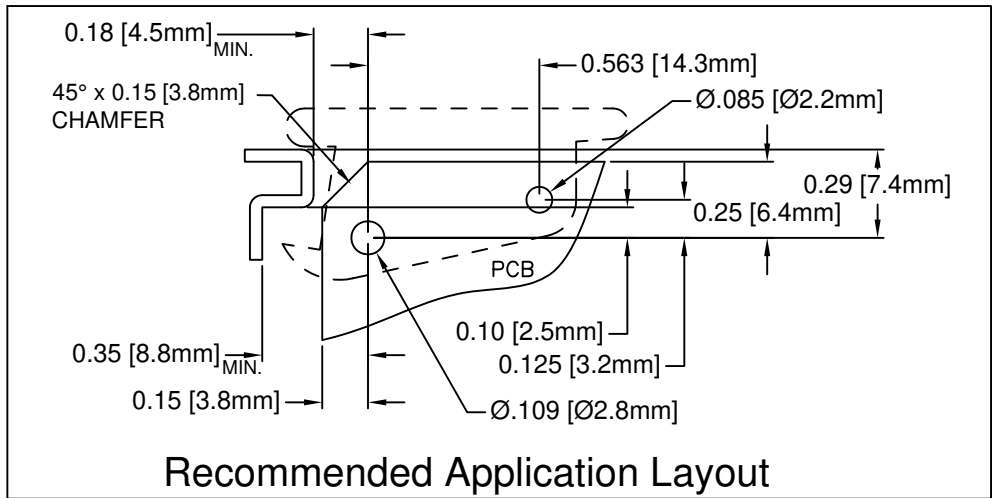

REV.	DESCRIPTION	DATE	APPROVED
F	Production Release	02/27/04	M. C.
G	Added Notes 4, 5, 6 & Color Options Sheet #2	05/17/16	J. C.

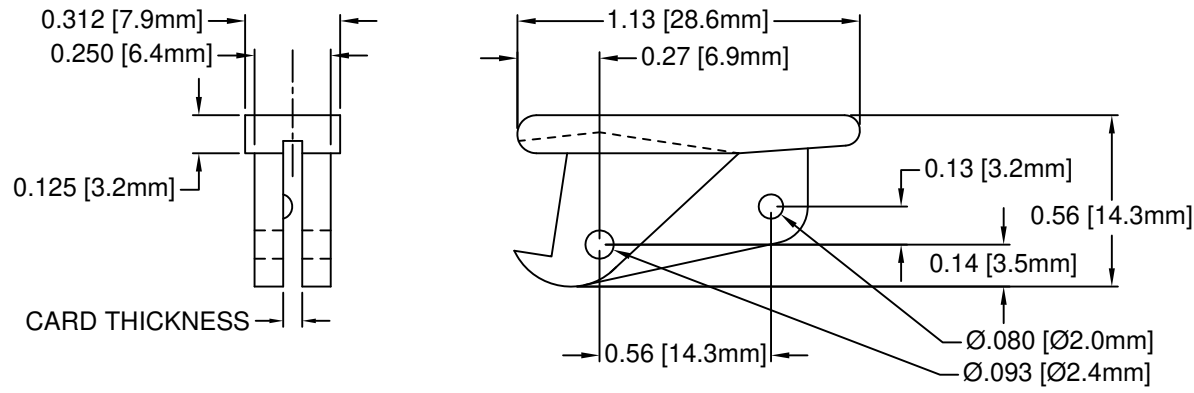

PART NO.	COLOR	ROLL PIN	CARD THICKNESS
LP-36 NT	NATURAL	RP-250	1/16"(1.6mm)
LP-36 WE	WHITE	RP-250	
LP-36 XX	SEE S.#2	RP-250	

5. PRE-ASSEMBLED ROLL PINS AVAILABLE UPON REQUEST.
4. ROLL PINS INCLUDED. PACKAGED SEPARATELY.
3. MATERIAL: NYLON 6/6, 94V-2, WHITE.
2. MATERIAL: NYLON 6/6, 94V-2, NATURAL.
1. GENERAL SPECIFICATIONS: BIVAR MOLDED COMPONENT SPECIFICATION BV00-E101.

STANDARD TOLERANCE (UNLESS OTHERWISE SPECIFIED)		 BIVAR [®] 4 THOMAS, IRVINE, CA. 92618 TEL: (949) 951-8808 FAX: (949) 951-3974	
DECIMALS	ANGULAR		
.X ± .1	X° ± 1°	 TITLE: CIRCUIT BOARD CARD EJECTOR	
.XX ± .01			
.XXX ± .005		PART NO: LP-36	
DESIGNED: S. Irving	DATE: 05/19/98	REVISION: G	
CHECKED: M. Chen	DATE: 09/09/03	CAGE CODE : 32559 SHEET # 1 OF 2	
CAD GENERATED DOCUMENT. DO NOT MEASURE DRAWING.			

OTHER AVAILABLE COLORS
 * SEE TABLE FOR ORDERING INFORMATION

REV.	DESCRIPTION	DATE	APPROVED
	SEE SHEET #1		

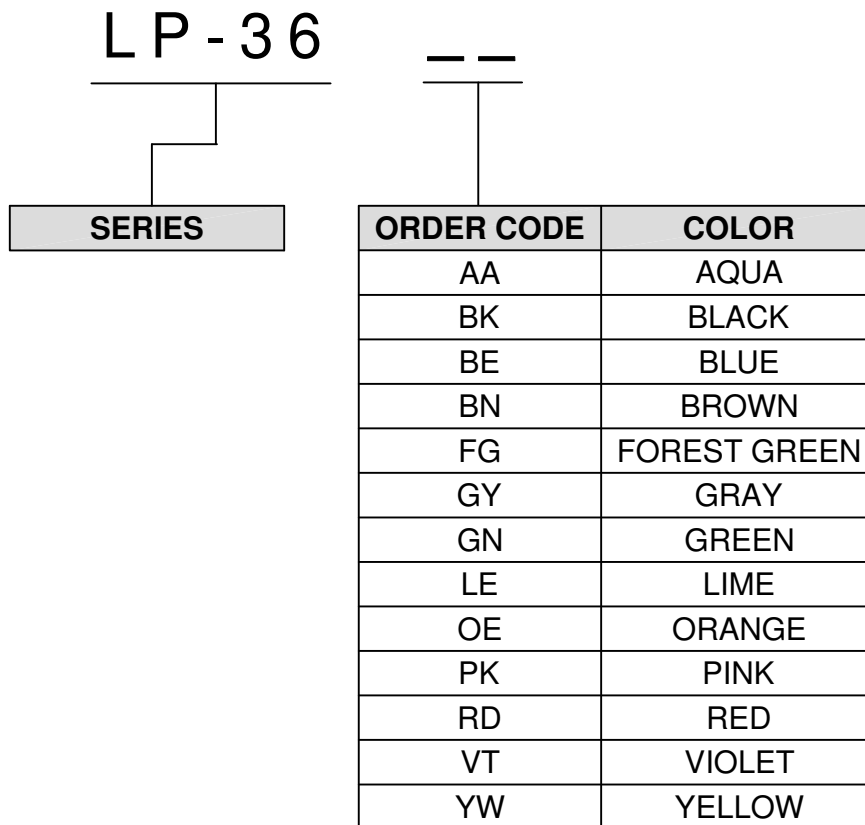

6. PARTS ARE DYED TO COLOR UPON REQUEST.

STANDARD TOLERANCE (UNLESS OTHERWISE SPECIFIED) DECIMALS ANGULAR		BIVAR [®] 4 THOMAS, IRVINE, CA. 92618 TEL: (949) 951-8808 FAX: (949) 951-3974	
		TITLE: CIRCUIT BOARD CARD EJECTOR	
DESIGNED: S. Irving	DATE: 05/19/98	PART NO: LP-36	REVISION: G
CHECKED: M. Chen	DATE: 09/09/03	CAGE CODE : 32559	SHEET # 2 OF 2
CAD GENERATED DOCUMENT. DO NOT MEASURE DRAWING.			