

PRODUCT NUMBER

98464-X61-XX-XXXLF

PLATING
S = 0.38µm GOLD/GXT ON CONTACT AREA
2µm MIN MATTE TIN ON TAIL

G = 0.76µm GOLD/GXT ON CONTACT AREA
2µm MIN MATTE TIN ON TAIL

F = GOLD FLASH ON CONTACT AREA
2µm MIN MATTE TIN ON TAIL

T = 2.0-5.0µm TIN FULL PLATED
1.27µm Ni MIN UNDERPLATING

RoHS COMPATIBLE, SEE NOTE 8
POLARIZATION (SEE NOTE 7)
PACKAGING OPTIONAL LETTER (SEE NOTE 5)
TOTAL NB OF POSITIONS, 04 TO 50
COLOR OPTION, NOTE 1

NOTES:

- MATERIAL HOUSING: HIGH TEMP. THERMOPLASTIC UL 94V-0
- = STANDARD COLOR CREAM
B = OPTIONAL COLOR BLACK
- MATERIAL TERMINAL: COPPER ALLOY
- TO DETERMINE DIMENSIONS:
N = NUMBER OF POSITIONS PER ROW
- 7N MIN. PIN RETENTION IN EITHER DIRECTION.
- PACKAGING:
= STANDARD PACKAGING IN POLYBAGS
- = POLYBAGS WHEN POLARISATION FEATURE APPLICABLE
U = TUBE AVAILABLE FROM 06 TO 50 POS

6. DIM "C" = (N x 2.00) + 1.4
EXAMPLE : N = 7
DIM "C" = (7 x 2.00) + 1.4 = 15.4mm

7. FOR POLARIZATION, SPECIFIED PIN
EXAMPLE: A03= ROW A, POSITION 03 TO OMIT PIN
OMIT FROM PRODUCT NUMBER IF THIS FEATURE IS NOT APPLICABLE

8. RoHS COMPATIBLE PRODUCT SPECIFICATIONS

- PLATING:
- "LF" MEANS THE PRODUCT IS LEAD-FREE,
2µm MINIMUM MATTE TIN OVER 1.27µm
MINIMUM NICKEL UNDERPLATE.
- MANUFACTURING PROCESS COMPATIBILITY
- THE HOUSING WILL WITHSTAND EXPOSURE TO
260°C ±5°C SOLDER BATH TEMPERATURE FOR
5 SECONDS IN A WAVE SOLDER APPLICATION
WITH A 1.6mm MIN THICK CIRCUIT BOARD.
- ALSO COMPATIBLE WITH REFLOW PROCESS
260°C PEAK TEMPERATURE FOR 30 SECONDES
MAX IN A CONVECTION, INFRA-RED OR VAPOR
PHASE OR REFLOW OVEN.
- LABELLING:
- MEETS PACKAGING SPECS AS PER GS-14-920
- THIS PRODUCT MEETS EUROPEAN DIRECTIVES
AND OTHER COUNTRY REGULATIONS AS DISCRIBED
IN GS-47-0004

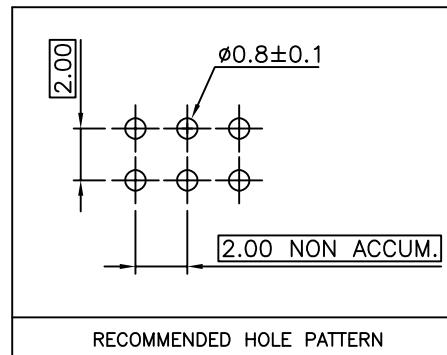
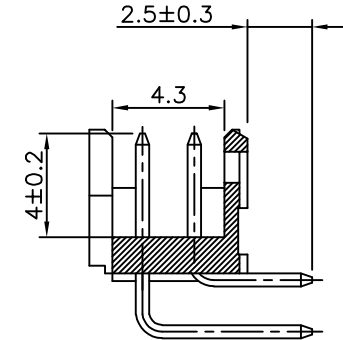
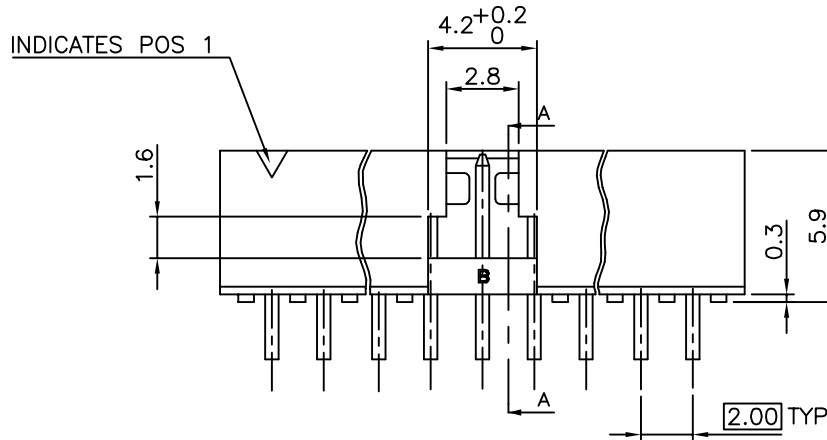
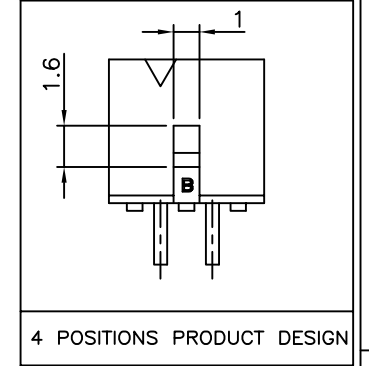
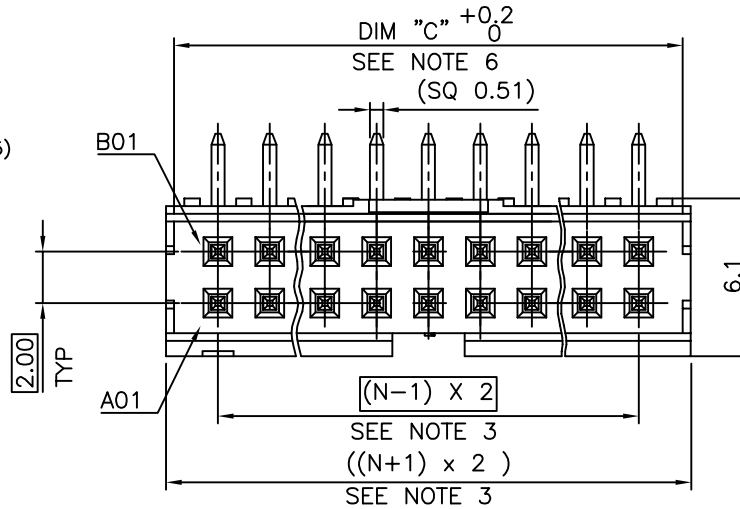

mat'l. code		surface	tolerance	projection	product family
SEE NOTES		ISO 1302	ISO 406	ISO 1101	MINITEK
ltr	ecn no	dr	date	title	
L	B-15815	JCO	13.09.11	SHR HEADER	
M	B-19190	LMU	14.10.24	2.00 RIGHT ANGLE TMT	
N	B-19797	AMA	14.12.16	scale 1:1	
P	B-19988	LMU	15.01.13	dwg no	
R	B-20254	LMU	15.02.16	sheet 1 of 1 size	
S	F-32710	LMU	19.02.18	98464 A3	
T	F-34292	LMU	22.07.19	type	
sheet index		revision	sheet	CUSTOMER Drawing	