

Customer Information Sheet

DRAWING No.: S8201-46R

IF IN DOUBT - ASK

©

NOT TO SCALE

THIRD ANGLE PROJECTION

ALL DIMENSIONS IN mm

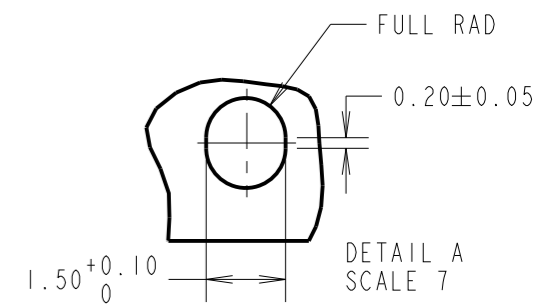
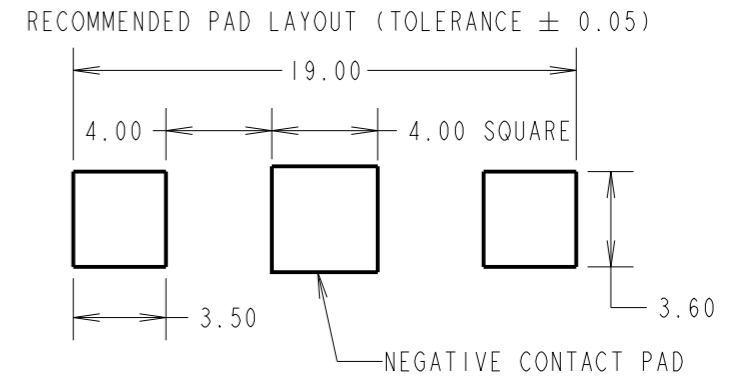
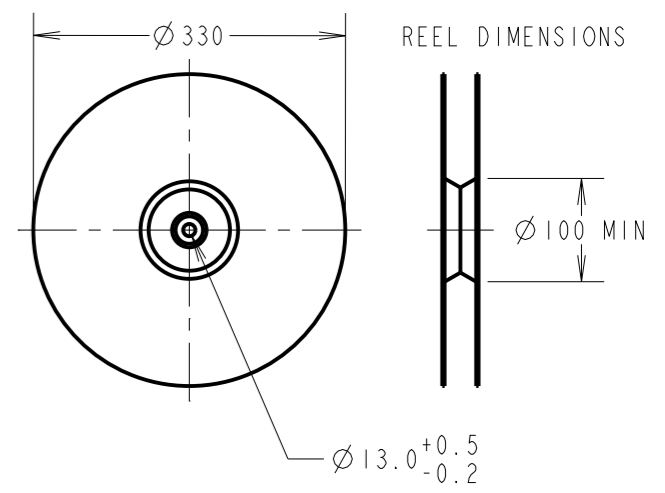
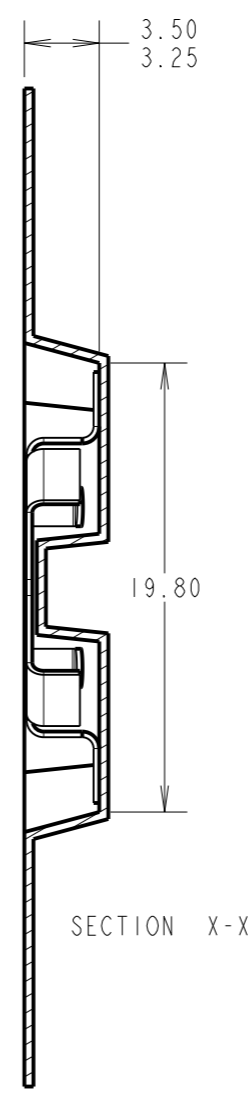
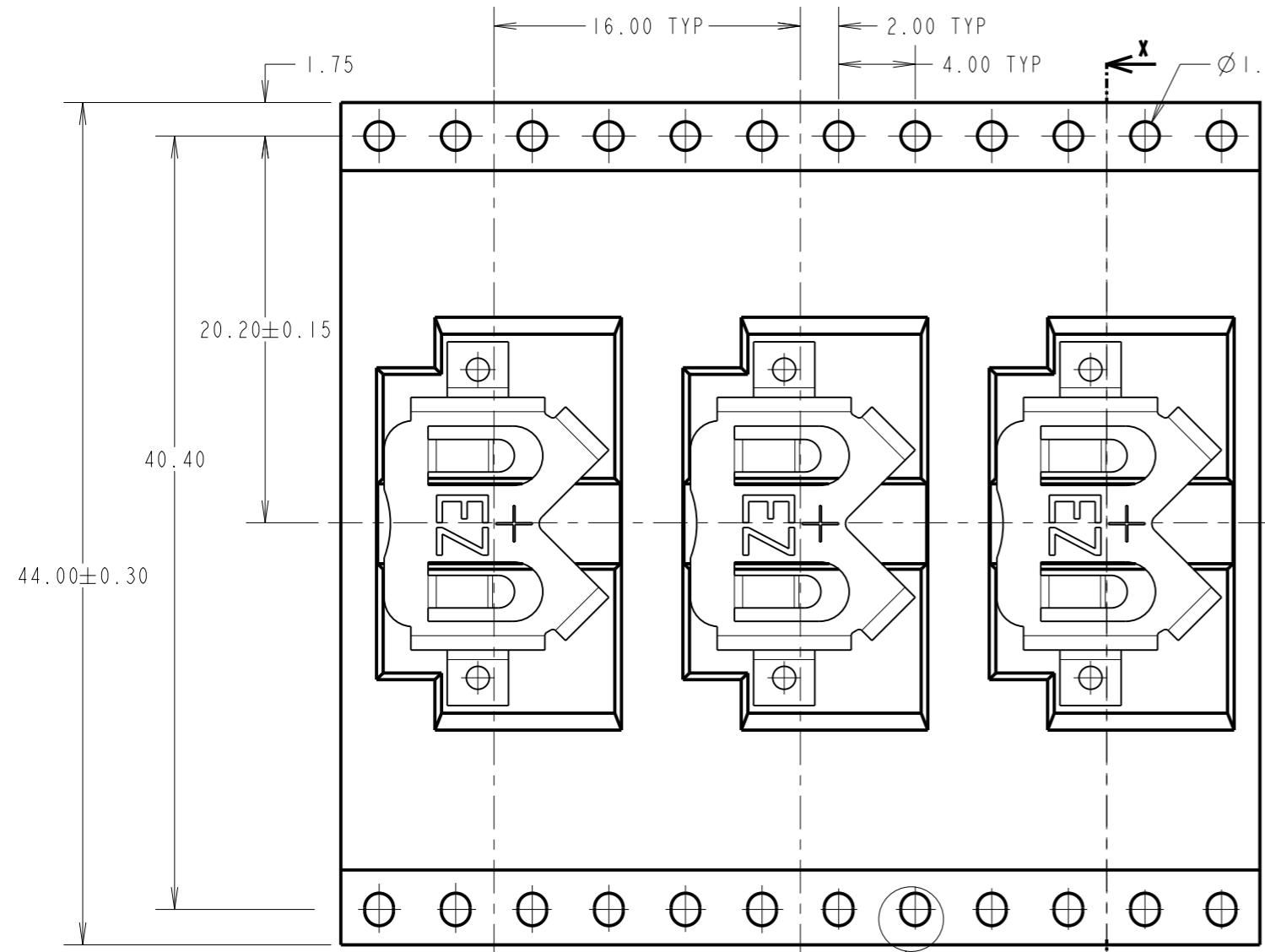

SINGLE COMPONENT DIMENSIONS

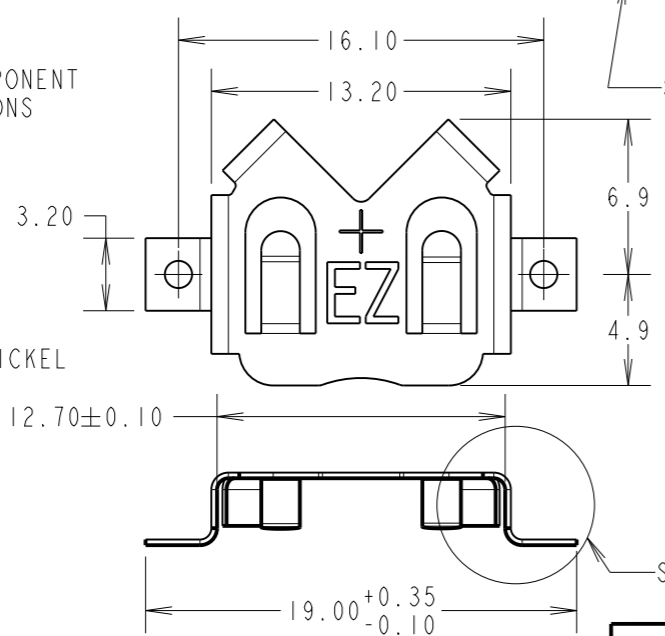

SEE DETAIL A

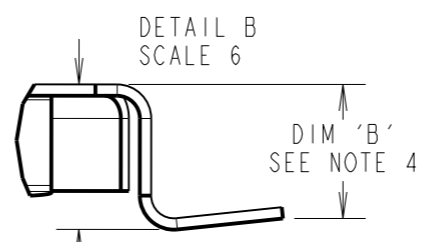

(DIM 'A') 3.20±0.10

SEE DETAIL B

FINISHED REELING DIRECTION

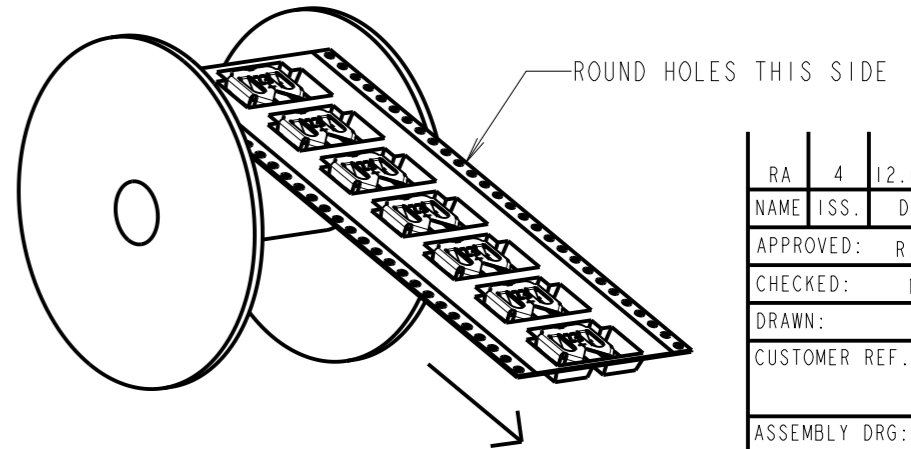

SPECIFICATION:
MATERIAL = PHOSPHOR BRONZE
FINISH:
46 = 3µm 100% TIN, OVER NICKEL

- NOTES:
1. QUANTITY PER REEL = 1000.
 2. THIS PRODUCT IS TAPED AND REELED IN ACCORDANCE WITH EIA-481-2 (ELECTRONIC INDUSTRIES ASSOCIATION).
 3. THIS PRODUCT IS SUITABLE FOR THE FOLLOWING BATTERIES: BR1220, BR1225, CR1220 AND CR1225.
 4. DIM 'B' IS EQUAL OR UP TO 0.25mm LESS THAN MEASURED VALUE OF DIM 'A'.

RA	4	12.04.22	31470
NAME	ISS.	DATE	CN/CO
APPROVED:		R.ALEXANDER	
CHECKED:		M.RUDKIN	
DRAWN:		R.ADDE	
CUSTOMER REF.:			
ASSEMBLY DRG:			

HARWIN
www.harwin.com
technical@harwin.com

THIS DRAWING AND ANY INFORMATION OR DESCRIPTIVE MATTER SET OUT HEREON ARE CONFIDENTIAL AND COPYRIGHT PROPERTY OF THE HARWIN GROUP AND MUST NOT BE DISCLOSED, LOANED, COPIED OR USED FOR MANUFACTURING, TENDERING OR FOR ANY OTHER PURPOSE WITHOUT THEIR WRITTEN PERMISSION.

TOLERANCES
X. = ±1mm
X.X = ±0.50mm
X.XX = ±0.20mm
X.XXX = ±0.01mm
ANGLES = ±5°
UNLESS STATED

MATERIAL: SEE ABOVE
FINISH: SEE ABOVE
S/AREA: mm²

TITLE: COIN CELL RETAINER (12mm) (TAPE & REELED)
DRAWING NUMBER: S8201-46R
SHT 2 OF 2