

# **User Manual**

## **GreenPAK Serial Debugger**

### **UM-GP-004**

## Contents

<b>Contents</b> .....	<b>2</b>
<b>Figures</b> .....	<b>2</b>
<b>Tables</b> .....	<b>2</b>
<b>1 Terms and Definitions</b> .....	<b>3</b>
<b>2 Description</b> .....	<b>4</b>
<b>3 Using GreenPAK Serial Debugger</b> .....	<b>6</b>
3.1 In-System Programming .....	6
3.2 In-System Debugging.....	6
3.3 Operation Examples.....	7
<b>Appendix A Schematic Diagram</b> .....	<b>8</b>
<b>Appendix B BOM</b> .....	<b>9</b>
<b>Appendix C ERRATA</b> .....	<b>10</b>
<b>Revision History</b> .....	<b>11</b>

## Figures

Figure 1: GreenPAK Serial Debugger Top View .....	5
Figure 2: PCB .....	5

## Tables

Table 1: GreenPAK Serial Debugger LED Indicators .....	4
Table 2: GreenPAK Serial Debugger On-Board Protection .....	4

## 1 Terms and Definitions

FET	Field-Effect Transistor
GND	Ground
HID	Human Interface Device
ISP	In-System Programming
LDO	Low Dropout Voltage Regulator
LED	Light Emitting Diode
NVM	Non-Volatile Memory
OCP	Over-Current Protection
OTP	Over-Temperature Protection
OVP	Overvoltage Protection
PCB	Printed Circuit Board
PTC	Positive Temperature Coefficient Resistor
SCL	I <sup>2</sup> C Clock Input
SCP	Short Circuit Protection
SDA	I <sup>2</sup> C Data Input/Output
USB	Universal Serial Bus
V <sub>DD</sub>	Power Supply

## GreenPAK Serial Debugger

## 2 Description

GreenPAK Serial Debugger (GSD) device can be used for programming GreenPAK products with multiple time Non-Volatile Memory (NVM) or for configuring the interconnect logic, the IOs, and the macrocells of all GreenPAK chips with I<sup>2</sup>C interface.

The GSD works with the GreenPAK Designer version 6.xx and above. Select the GSD in the “Development Platform Selector” window and click on the “Program” or “Emulate” button.

Supported operational systems:

- Windows - XP (SP3), Vista, 7, 8, and 8.1, 10
- Linux - any distribution with support for CDC and HID classes
- Mac OS - all versions starting from 10.7

GSD is the Human Interface Device (HID) and does not require any additional drivers.

The device runs as an I<sup>2</sup>C Master. The Data to read/write on the I<sup>2</sup>C Bus is conveyed by the USB interface with a speed of 12 Mb/s. I<sup>2</sup>C interface clock rate of GreenPAK Serial Debugger is up to 100 kHz.

Chip programming/emulation/debugging is done through the I<sup>2</sup>C protocol via four chip pins: V<sub>DD</sub>, SCL, SDA, and GND.

When the GSD is connected to USB, the “Power” LED turns on. The connected chip can be powered from the GSD or from an external power. GSD can deliver voltage from 0.9 V to 5.0 V with a maximum output current of up to 50 mA.

GSD detects the external power and switches off its V<sub>DD</sub> line (in this case, I<sup>2</sup>C pull-up resistors will be connected to the external power supply).

**Table 1: GreenPAK Serial Debugger LED Indicators**

GSD State	Power LED	Status LED
Standby mode	On	Off
Emulation mode	On	Blink
Program mode	On	Blink
Overvoltage protection at V <sub>DD</sub> line	Blink	Off
Over-temperature protection	Off	Off

**Table 2: GreenPAK Serial Debugger On-Board Protection**

Protection	Description
Over-current protection (OCP)	PTC limits maximum V <sub>DD</sub> current equals 50 mA.
Short circuit protection (SCP)	PTC limits maximum V <sub>DD</sub> current equals 50 mA.
Overvoltage protection (OVP)	When the external power supply voltage exceeded 5.6 V, FET U1 and power supply LDO IC2 are turned off and Power LED starts to blink.
Over-temperature protection (OTP)	When the IC2 temperature exceeds 75 °C, FET U1 and power supply LDO IC2 are turned off and Power and Status LEDs are also turned off.

GreenPAK Serial Debugger

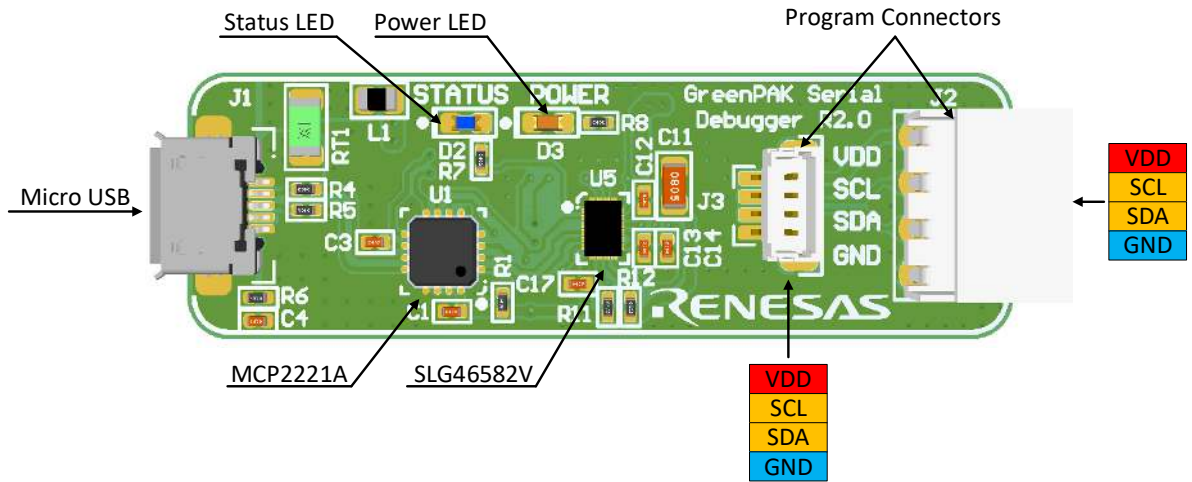

Figure 1: GreenPAK Serial Debugger Top View

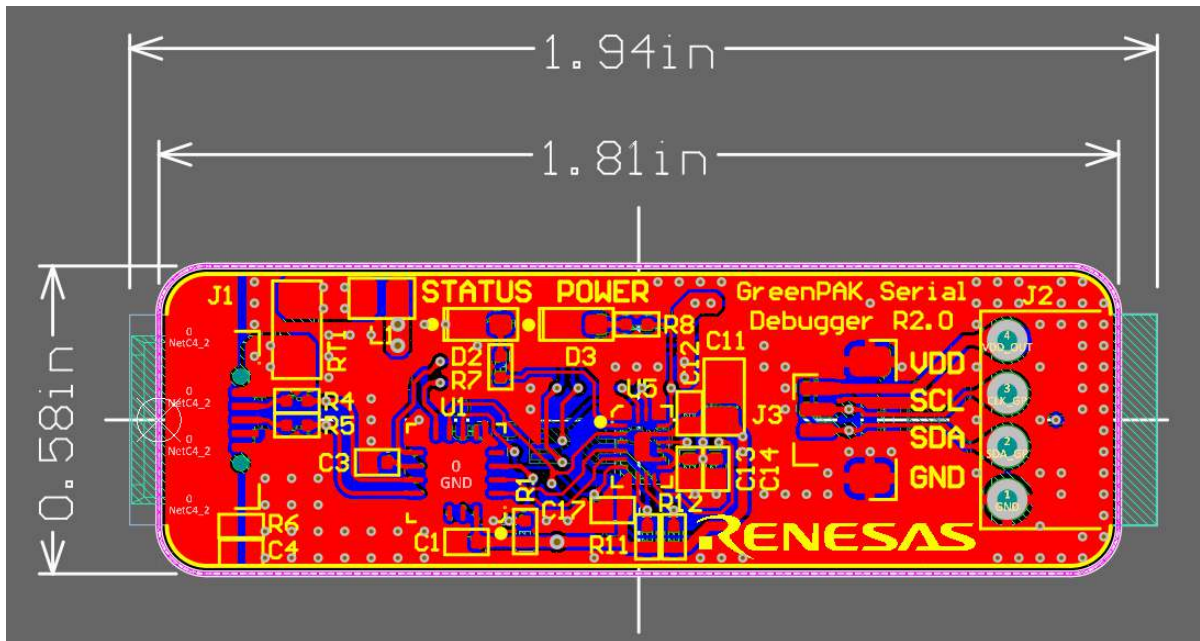

Figure 2: PCB

Note 1 All sizes in inches.

## 3 Using GreenPAK Serial Debugger

### 3.1 In-System Programming

The GSD allows emulating and programming chips with multiple time programmable Non-Volatile Memory only. The chip is programmed/emulated through the I<sup>2</sup>C protocol via four pins: V<sub>DD</sub>, SCL, SDA, and GND.

When the GSD is connected to the USB port, the "Power" LED turns on. The ISP connector (J2 or J3) should be connected to the external board. The programmed chip can be powered from the GSD or from the external power supply. The GSD detects the external power and switches off its V<sub>DD</sub> line (in this case, I<sup>2</sup>C pull-up resistors are connected to the external power supply).

There are two options for the User to make a connection between the GSD and their target board:

- The J2 connector has four signals for SDA, SCL, power, and ground. This connector can be used to make physical and electrical connection to the target board. To enable this, the User should place a duplicate of this connector on the target board. The part number of this connector is Molex Connector Corporation 0022152046. This connector was chosen for its small physical size.
- The J3 connector also has the same four signals for SDA, SCL, power, and ground. This connector has 0.1" spacing, which will support a variety of industry-standard cabling options. Additionally, Target Board Cable is included with the GSD. If the User prefers to use this option, the cabling mating connector on the target board must be chosen. The part number for this connector is BM04B-SRSS-TB(LF)(SN).

The GSD is equipped with on-board protection and LED indicators, please refer to [Table 1](#) and [Table 2](#) for more information.

For a more detailed description of the programming/emulating procedure please refer to the In-System Programming Guide.

### 3.2 In-System Debugging

GreenPAK Serial Debugger can be used for debugging/emulating any pre-programmed or blank GreenPAK chips that support I<sup>2</sup>C interface. It is possible to reconfigure the interconnect logic, the IOs, and the macrocells. However, all NVM changes cannot be saved and will be discarded after power off. The debugging/emulating process is done through the I<sup>2</sup>C protocol via four chip pins: V<sub>DD</sub>, SCL, SDA, and GND.

When the GSD is connected to the USB port, the "Power" LED turns on. The ISP connector (J2 or J3) should be connected to the external board. The debugged/emulated chip can be powered from the GSD or from the external power supply. The GSD detects the external power and switches off its V<sub>DD</sub> line (in this case, I<sup>2</sup>C pull-up resistors are connected to the external power supply).

See Section [3.1](#) for physical connections between the GSD and the target board.

GreenPAK Serial Debugger

3.3 Operation Examples

1. Internal VDD.

GreenPAK SLG46826V directly supplied only from GreenPAK Serial Debugger R2.0.

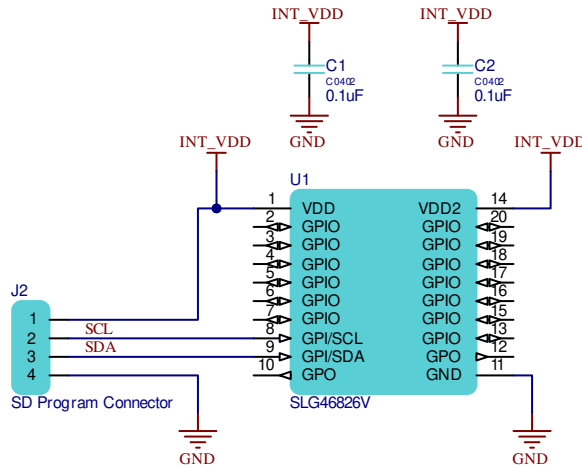

2. External VDD.

GreenPAK SLG46826V supplied from EXTERNAL VDD, but it must be connect to GreenPAK Serial Debugger 2.0.

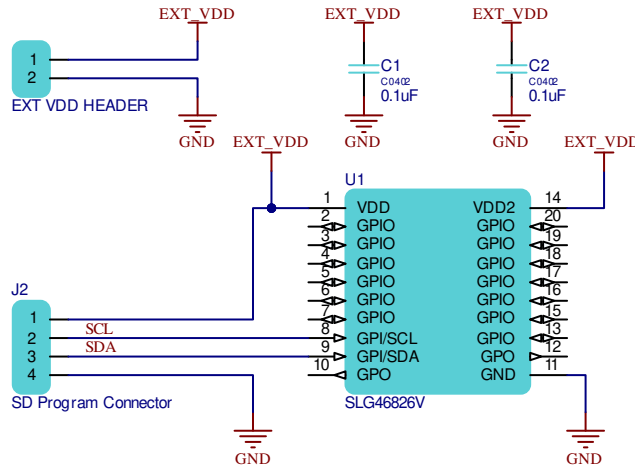

GreenPAK Serial Debugger

Appendix A Schematic Diagram

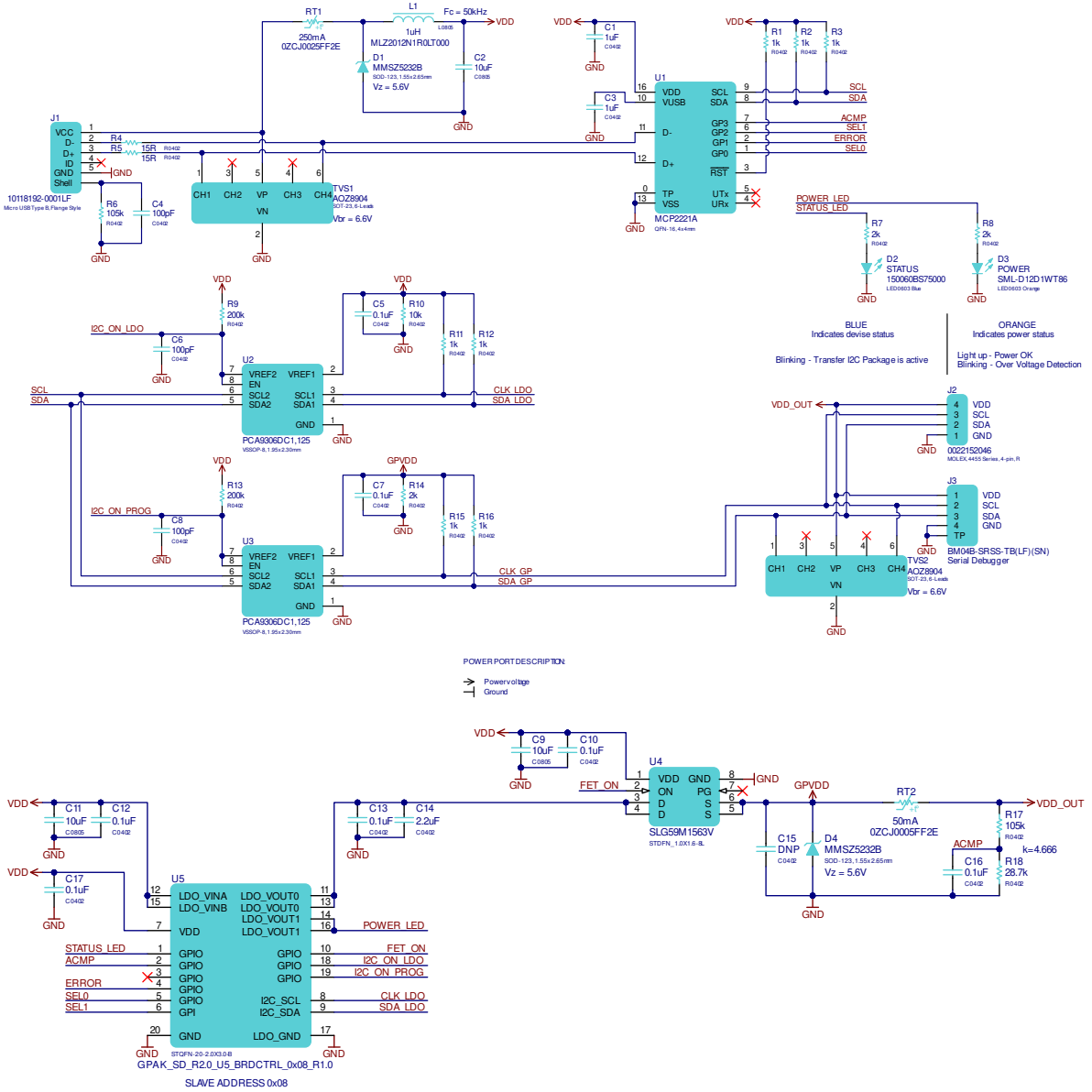



## Appendix B BOM

#	Designator	Description	Footprint	Quantity
1	C1, C3	CC0402KRX5R6BB105	C0402	2
2	C2	0805ZC106KAT4A	C0805	1
3	C4, C6, C8	885012205001	C0402	3
4	C5, C7, C10, C12, C13, C16, C17	0402X104K100CT	C0402	7
5	C9, C11	CL21A106KOQNNWE	C0805	2
6	C14	GRT155R61A225KE01D	C0402	1
7	C15	DNP	C0402	1
8	D1, D4	MMSZ5232B RHG	SOD-123, 1.55x2.65mm	2
9	D2	150060BS75000	LED0603 Blue	1
10	D3	SML-D12D1WT86	LED0603 Orange	1
11	J1	10118192-0001LF	Micro USB Type B, Flange Style	1
12	J2	0022152046	MOLEX, 4455 Series, 4-pin, R	1
13	J3	BM04B-SRSS-TB(LF)(SN)	SH SMD Header, V, 4-pins	1
14	L1	MLZ2012N1R0LT000	L0805	1
15	R1, R2, R3, R11, R12, R15, R16	RC0402JR-071KL	R0402	7
16	R4, R5	RC0402FR-0715RL	R0402	2
17	R6, R17	RMCF0402FT105K	R0402	2
18	R7, R8, R14	RC0402JR-072KL	R0402	3
19	R9, R13	RC0402FR-07200KL	R0402	2
20	R10	RC0402JR-0710KL	R0402	1
21	R18	RT0402FRE0728K7L	R0402	1
22	RT1	0ZCJ0025FF2E	PTC1206	1
23	RT2	0ZCJ0005FF2E	PTC1206	1
24	TVS1, TVS2	AOZ8904CIL	SOT-23, 6-Leads	2
25	U1	MCP2221A-I/ML	QFN-16, 4x4mm	1
26	U2, U3	PCA9306DC1,125	VSSOP-8, 1.95x2.30mm	2
27	U4	SLG59M1563V	STDFN_1.0X1.6-8L	1
28	U5	SLG46582V	STQFN-20-2.0X3.0-B	1

### Appendix C ERRATA

1. Previous revisions: In System Programming (ISP) Board and GreenPAK Serial Debugger R1.0 stable functionality guaranteed on voltage range **from 3.3 to 5.0V** with a maximum output current of up to 50 mA.

## Revision History

Revision	Date	Description
2.1	16-Jun-2023	Fixed typos
1.2	13-Mar-2023	Updated to revision 2.0
1.1	22-Mar-2022	Renesas rebranding
1.0	20-Oct-2020	Initial version

---

## GreenPAK Serial Debugger

### Status Definitions

Status	Definition
DRAFT	The content of this document is under review and subject to formal approval, which may result in modifications or additions.
APPROVED or unmarked	The content of this document has been approved for publication.

### RoHS Compliance

Renesas Electronics Corporation's suppliers certify that its products are in compliance with the requirements of Directive 2011/65/EU of the European Parliament on the restriction of the use of certain hazardous substances in electrical and electronic equipment. RoHS certificates from our suppliers are available on request.

## IMPORTANT NOTICE AND DISCLAIMER

RENESAS ELECTRONICS CORPORATION AND ITS SUBSIDIARIES (“RENESAS”) PROVIDES TECHNICAL SPECIFICATIONS AND RELIABILITY DATA (INCLUDING DATASHEETS), DESIGN RESOURCES (INCLUDING REFERENCE DESIGNS), APPLICATION OR OTHER DESIGN ADVICE, WEB TOOLS, SAFETY INFORMATION, AND OTHER RESOURCES “AS IS” AND WITH ALL FAULTS, AND DISCLAIMS ALL WARRANTIES, EXPRESS OR IMPLIED, INCLUDING, WITHOUT LIMITATION, ANY IMPLIED WARRANTIES OF MERCHANTABILITY, FITNESS FOR A PARTICULAR PURPOSE, OR NON-INFRINGEMENT OF THIRD PARTY INTELLECTUAL PROPERTY RIGHTS.

These resources are intended for developers skilled in the art designing with Renesas products. You are solely responsible for (1) selecting the appropriate products for your application, (2) designing, validating, and testing your application, and (3) ensuring your application meets applicable standards, and any other safety, security, or other requirements. These resources are subject to change without notice. Renesas grants you permission to use these resources only for development of an application that uses Renesas products. Other reproduction or use of these resources is strictly prohibited. No license is granted to any other Renesas intellectual property or to any third party intellectual property. Renesas disclaims responsibility for, and you will fully indemnify Renesas and its representatives against, any claims, damages, costs, losses, or liabilities arising out of your use of these resources. Renesas' products are provided only subject to Renesas' Terms and Conditions of Sale or other applicable terms agreed to in writing. No use of any Renesas resources expands or otherwise alters any applicable warranties or warranty disclaimers for these products.

(Disclaimer Rev.1.0 Mar 2020)

### Corporate Headquarters

TOYOSU FORESIA, 3-2-24 Toyosu,  
Koto-ku, Tokyo 135-0061, Japan  
[www.renesas.com](http://www.renesas.com)

### Contact Information

For further information on a product, technology, the most up-to-date version of a document, or your nearest sales office, please visit:  
[www.renesas.com/contact/](http://www.renesas.com/contact/)

### Trademarks

Renesas and the Renesas logo are trademarks of Renesas Electronics Corporation. All trademarks and registered trademarks are the property of their respective owners.