

Development Board EPC9003C Quick Start Guide

200 V Half-bridge with Gate Drive, Using EPC2010C

Revision 4.1

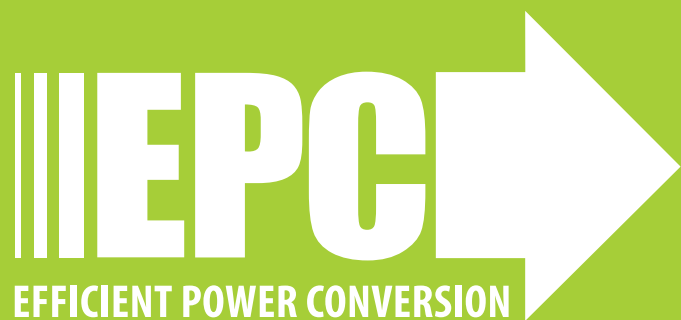

DESCRIPTION

The EPC9003C development board is a 200 V maximum device voltage, 22 A maximum output current, half bridge with onboard gate drives, featuring the EPC2010C GaN field effect transistor (FET). The purpose of this development board is to simplify the evaluation process of the EPC2010C by including all the critical components on a single board that can be easily connected into the majority of existing converter topologies.

The EPC9003C development board measures 2" x 2" and contains two EPC2010C GaN FETs in a half bridge configuration with the On-Semi NCP51820 gate driver. The board also contains all critical components and the layout supports optimal switching performance. There are also various probe points to facilitate simple waveform measurement and efficiency calculation. A block diagram of the circuit is given in figure 1.

For more information on EPC2010C please refer to the datasheet available from EPC at www.epc-co.com. The datasheet should be read in conjunction with this quick start guide.

Table 1: Performance Summary ($T_A = 25^\circ\text{C}$) EPC9003C

Symbol	Parameter	Conditions	Min	Nominal	Max	Units
V_{DD}	Gate Drive Input Supply Range		10		12	V
V_{IN}	Bus Input Voltage Range ⁽¹⁾				160	V
I_{OUT}	Switch Node Output Current ⁽²⁾				5	A
V_{PWM}	PWM Logic Input Voltage Threshold ⁽³⁾	Input 'High'	3.5		5.5	V
		Input 'Low'	0		1.5	
	Minimum 'High' State Input Pulse Width	V_{PWM} rise and fall time < 10ns	50			ns
	Minimum 'Low' State Input Pulse Width ⁽⁴⁾	V_{PWM} rise and fall time < 10ns	200			

(1) Maximum input voltage depends on inductive loading, maximum switch node ringing must be kept under 200 V for EPC2010C.

(2) Maximum current depends on die temperature – actual maximum current is affected by switching frequency, bus voltage and thermal cooling.

(3) When using the on board logic buffers, refer to the NCP51820 datasheet when bypassing the logic buffers.

(4) Limited by time needed to 'refresh' high side bootstrap supply voltage.

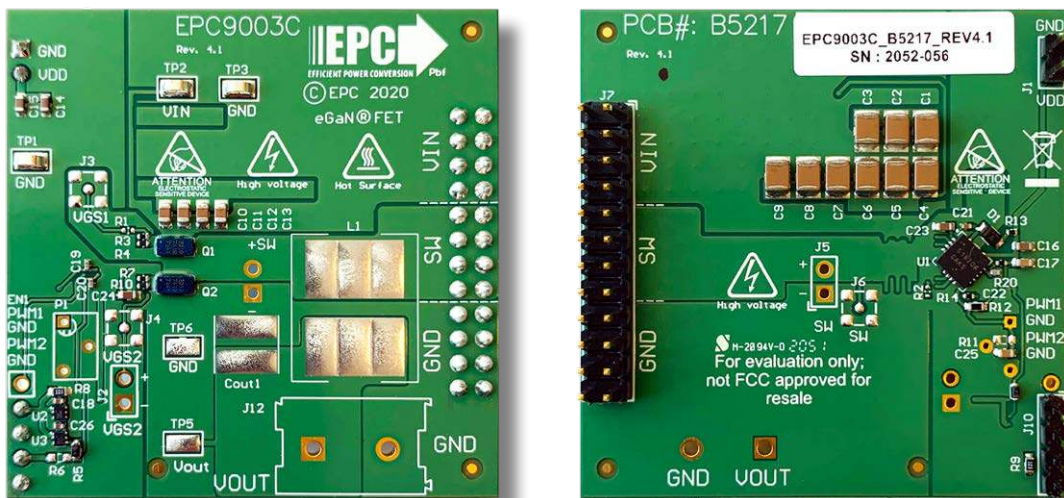

Front view

Back view

EPC9003C development board

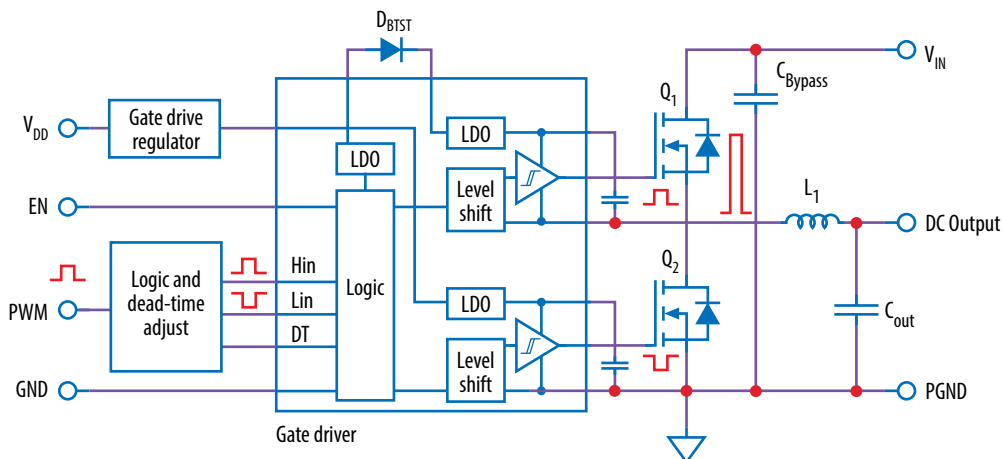

Figure 1: Block diagram of EPC9003C development board

QUICK START PROCEDURE

The EPC9003C development board is easy to set up as a buck or boost converter to evaluate the performance of two EPC2010C eGaN FETs. In addition to the deadtime features of the NCP51820 gate driver, this board includes a dead-time generating circuit that adds a delay from when the gate signal of one FET is commanded to turn off, to when the gate signal of the other FET is commanded to turn on. In the default configuration, the NCP51820 gate driver is set mode D (no-dead time, no-cross conduction protection - refer to datasheet for NCP51820) and the on-board dead time circuit provides the necessary dead time and ensures that both the high and low side FETs will not be turned on at the same time thus preventing a shoot through condition.

Single/dual PWM signal input settings

PWM1 and PWM2. Both input ports are used as inputs in dual-input mode where PWM1 connects to the upper FET and PWM2 connects to the lower FET. The PWM1 input port is used as the input in single-input mode where the circuit will generate the required complementary PWM with preset dead time for the FETs as shown in figure 2(a). This is the default configuration.

To select dual input mode, the zero-ohm resistor in position R5 needs to be removed and installed in position R6 as shown in figure 2(b).

Note: In dual mode there is no shoot-through protection as both gate signals can be set high at the same time. 2. The NCP51820 has an on-chip deadtime generator with several modes of operation. The EPC9003C disables the on-chip deadtime to maximize end user flexibility, but it makes the on-chip deadtime modes accessible through P1, R11, and R12. Refer to the NCP51820 datasheet for details on setting the dead time using P1, R11 and R12.

Buck converter configuration

To operate the board as a buck converter, either a single or dual PWM input can be chosen. Figure 3(a) shows the connection setup for single PWM input mode and figure 3(b) for the dual PWM input mode.

Note: It is important to provide the correct PWM signals that includes dead-time and polarity when operating in dual PWM input mode and not making use of the gate driver dead time function.

Once the input source and dead-time settings have been chosen and set, then the board can be operated.

1. With power off, connect the input power supply bus to VIN and ground/return to GND.
2. With power off, connect the switch node (SW) of the half bridge to your circuit as required (half bridge configuration). Or use the provided pads for inductor (L1) and output capacitors (Cout), as shown in figure 3.
3. With power off, connect the gate drive supply to VDD (J1, Pin-1) and ground return to GND (J1, Pin-2 indicated on the bottom side of the board).
4. With power off, connect the input PWM control signal to PWM1 and/or PWM2 according to the input mode setting chosen and ground return to any of GND J10 pins indicated on the bottom side of the board.
5. Turn on the gate drive supply – make sure the supply is at least 10 V but does not exceed 12 V.
6. Turn on the controller / PWM input source.
7. Making sure the initial input supply voltage is 0 V, turn on the power and slowly increase the voltage to the required value (**do not exceed the absolute maximum voltage**). Probe switching node to see switching operation.

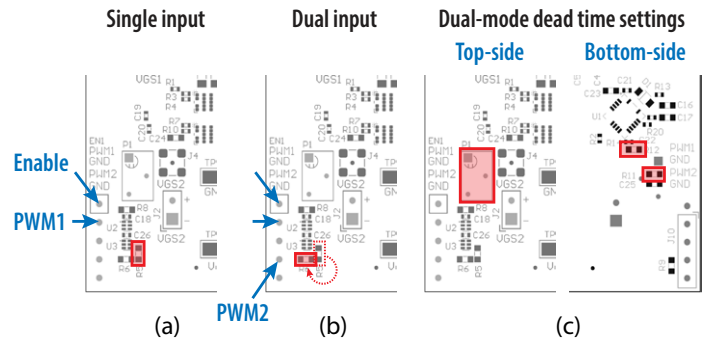

Figure 2: Input mode selection on J630

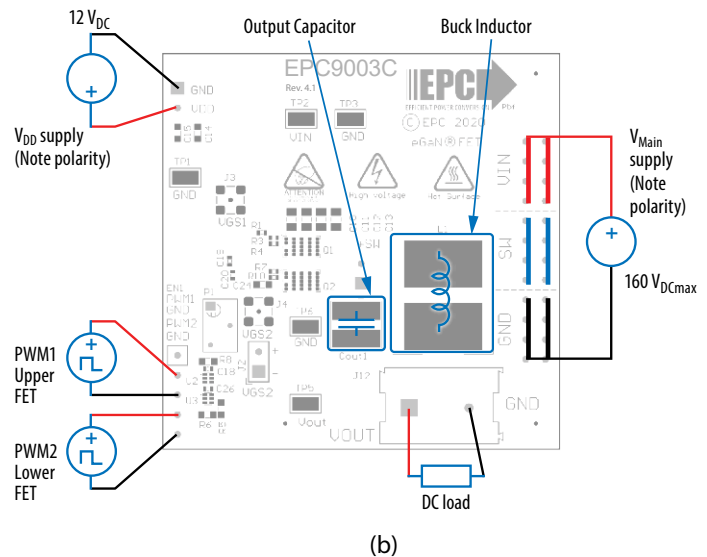
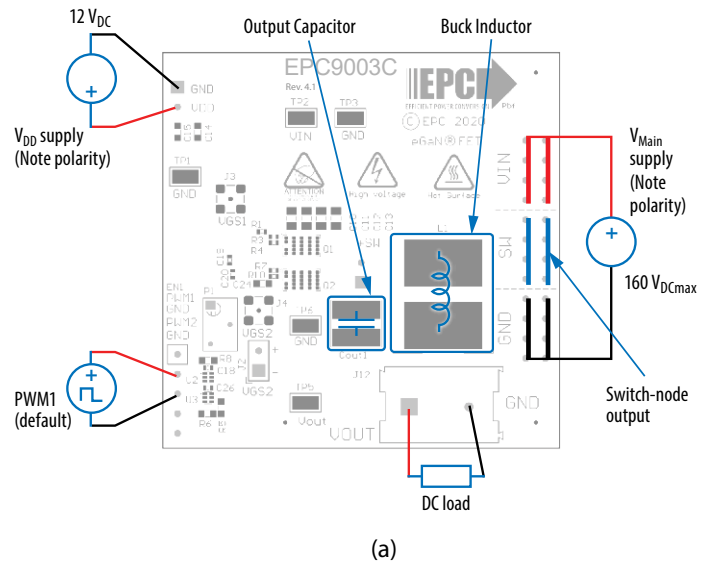

Figure 3: (a) Single-PWM input buck converter (b) Dual-PWM input buck converter configurations showing the supply, output capacitor, inductor, PWM, and load connections.

8. Once operational, adjust the PWM control, bus voltage, and load within the operating range and observe the output switching behavior, efficiency, and other parameters.
9. For shutdown, please follow steps in reverse.

Boost Converter configuration

Warning: Never operate the boost converter mode without a load as the output voltage can increase beyond the maximum ratings.

To operate the board as a boost converter, either a single or dual PWM input can be chosen. Figure 4(a) shows the connection setup for single PWM input mode and figure 4(b) for the dual PWM input mode.

Notes:

1. It is important to provide the correct PWM signals that includes dead-time and polarity when operating in dual PWM input mode and not making use of the gate driver dead time function.
2. Boost mode PWM converters are theoretically capable of generating arbitrarily high voltages, limited only by losses and component ratings. Review the operation of boost mode converters and make sure to avoid combinations of duty cycle and load that will generate higher voltages than the voltage rating of the development board and attached components.

Once the input source, dead-time settings and bypass configurations have been chosen and set then the boards can be operated.

1. The inductor (L1) and input capacitors (labeled as Cout) can either be soldered onto the board, as shown in figure 4, or provided off board.
2. With power off, connect the input power supply bus to V_{OUT} and ground / return to GND, or externally across the capacitor if the inductor L1 and Cout are provided externally. Connect the output voltage (labeled as VIN) to your circuit as required, e.g., resistive load.
3. With power off, connect the gate drive supply to V_{DD} (J1, Pin-1) and ground return to GND (J1, Pin-2) indicated on the bottom side of the board).
4. With power off, connect the input PWM control signal to PWM1 and/or PWM2 according to the input mode setting chosen and ground return to any of GND J10 pins indicated on the bottom side of the board.
5. Turn on the gate drive supply – make sure the supply is at least 10 V but does not exceed 12 V.
6. Turn on the controller / PWM input source.
7. **Making sure the output is not open circuit**, and the input supply voltage is initially 0 V, turn on the power and slowly increase the voltage to the required value (**do not exceed the absolute maximum voltage**). Probe switching node to see switching operation.
8. Once operational, adjust the PWM control, bus voltage, and load within the operating range and observe the output switching behavior, efficiency, and other parameters. Observe device temperature for operational limits.
9. For shutdown, please follow steps in reverse.

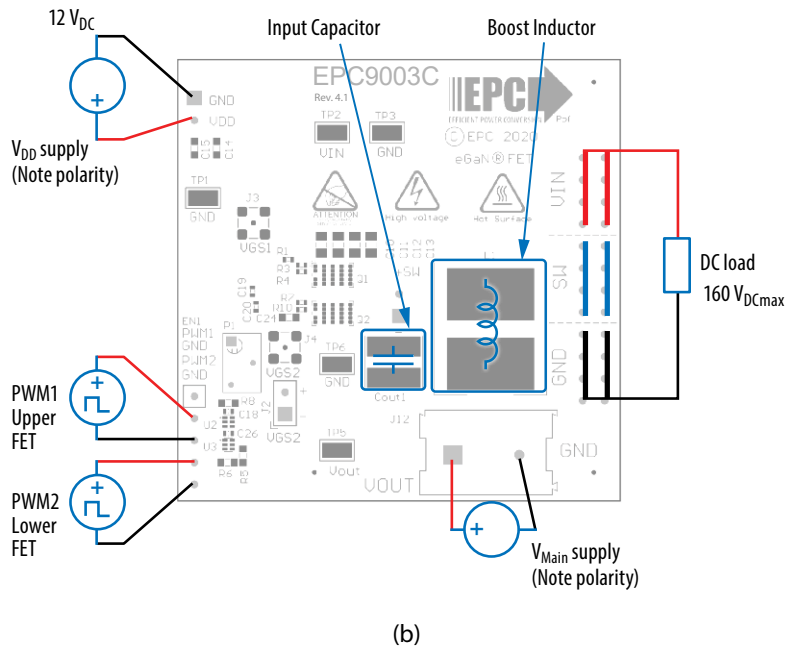
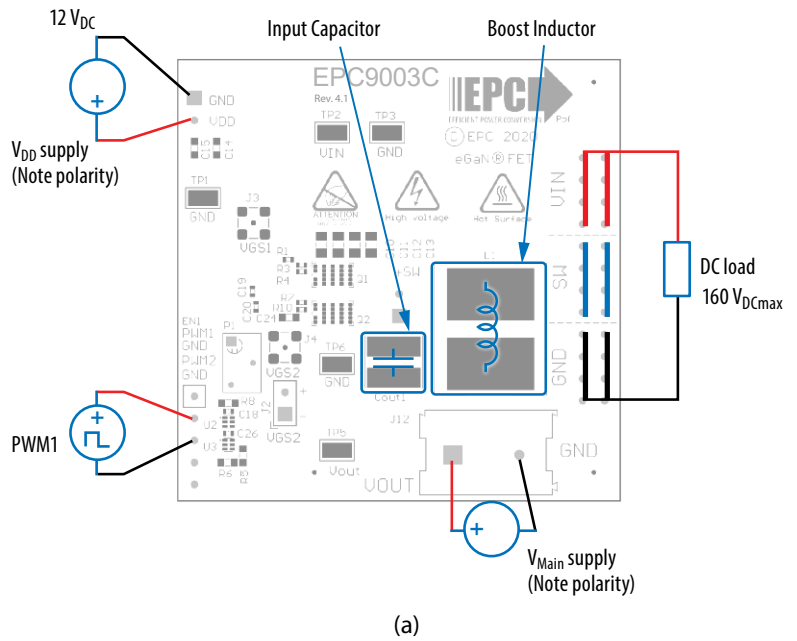

Figure 4: (a) Single-PWM input boost converter (b) Dual-PWM input boost converter configurations showing the supply, inductor, input capacitor, PWM, and load connections.

MEASUREMENT CONSIDERATIONS

Measurement connections are shown in figure 5. Figure 6 shows an actual switch-node voltage measurement when operating the board as a buck converter.

When measuring the switch node voltage containing high-frequency content, care must be taken to provide an accurate high-speed measurement. An optional two pin header (J5) and an MMCX connector (J6) are provided for switch-node measurement.

A differential probe is recommended for measuring the high-side bootstrap voltage. IsoVu probes from Tektronix has mating MMCX connector.

For regular passive voltage probes (e.g. TPP1000) measuring switch node using MMCX connector, probe adaptor is available. PN: 206-0663-xx.

NOTE. For information about measurement techniques, the EPC website offers: “AN023 Accurately Measuring High Speed GaN Transistors” and the How to GaN educational video series, including: HTG09-Measurement

THERMAL CONSIDERATIONS

The EPC9003C is intended for bench evaluation with low ambient temperature and convection cooling. The addition of a heat-spreader or heatsink and forced air cooling can significantly increase the current rating of these devices, but care must be taken to not exceed the absolute maximum die temperature of 150°C.

NOTE. The EPC9003C development board does not have any current or thermal protection on board. For more information regarding the thermal performance of EPC eGaN FETs, please consult: D. Reusch and J. Glaser, *DC-DC Converter Handbook, a supplement to GaN Transistors for Efficient Power Conversion*, First Edition, Power Conversion Publications, 2015.

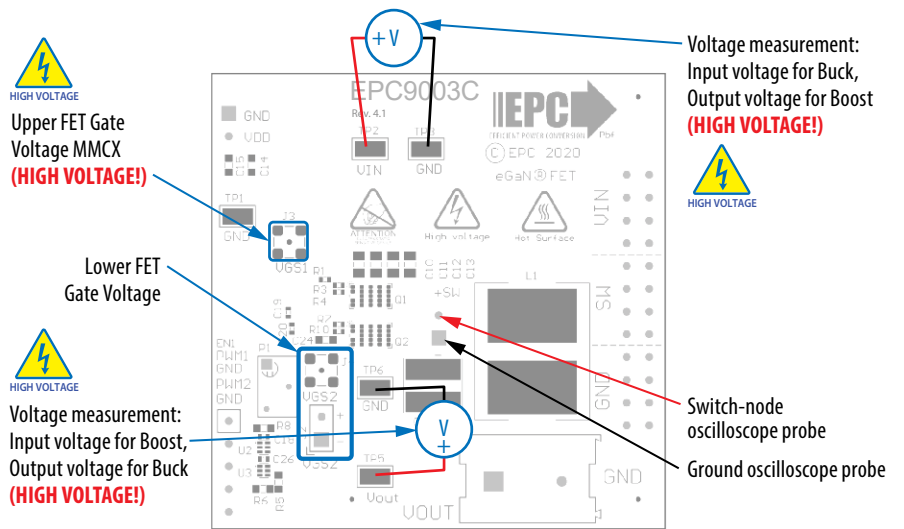

(a)

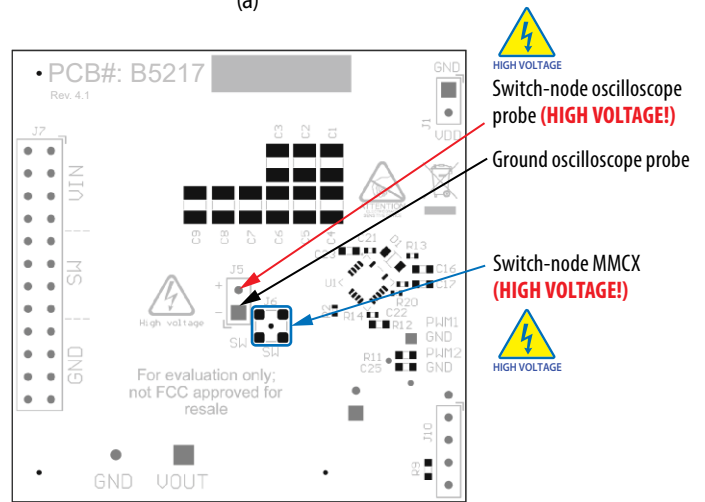

(b)

Figure 5 Measurement points (a) front side, (b) Back side

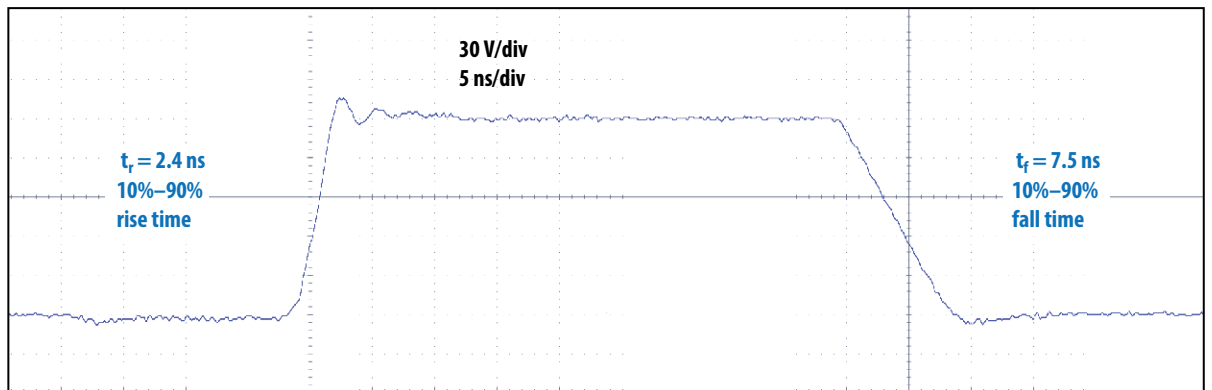

Waveform 8 A, $V_{IN} = 160\text{ V}$, $V_{OUT} = 28\text{ V}$, $L = 200\text{ kHz}$

Figure 6: Typical switch-node waveform when operated as a buck converter

Table 2: Bill of Materials

Item	Qty	Reference	Part Description	Manufacturer	Part Number
1	9	C1, C2, C3, C4, C5, C6, C7, C8, C9	0.33 μ F 250 V	TDK	CGA6M3X7T2E334K200AA
2	4	C10, C11, C12, C13	0.1 μ F 250 V	TDK	C2012X7T2E104K125AA
3	4	C14, C16, C23, C24	1 μ F 25 V	TDK	C1608X7R1E105K080AB
4	1	C15	4.7 μ F 25 V	TDK	C1608X5R1E475K080AC
5	2	C17, C25	0.1 μ F 25 V	TDK	C1608X7R1E104K080AA
6	2	C18, C26	0.1 μ F 25 V	TDK	C1005X7R1E104K050BB
7	2	C19, C20	100 pF 50 V	Yageo	CC0402KRX7R9BB101
8	1	C21	0.47 μ F 25 V	TDK	C2005X5R1E474K050BB
9	1	C22	15 pF 50 V	TDK	CGA2B2C0G1H150J050BA
10	2	Q1, Q2	200 V 25 m Ω GaN FET	EPC	EPC2010C
11	2	R5, R15	300 Ω	Yageo	RC0603FR-07300RL
12	2	R8, R9	10 k	Yageo	RC0603JR-0710KL
13	4	R3, R4, R7, R10	4.7 Ω	Stackpole	RMCF0402FT4R70
14	1	R12	10 k	Yageo	RC0603JR-0710KL
15	1	R13	2 Ω	Stackpole	RMCF0402JT2R00
16	1	R14	1 Ω	ROHM	MCR01MRT1JR0
17	1	R20	10 k	Panasonic	ERJ-2RKF1002X
18	5	TP1, TP2, TP3, TP5, TP6	SMD probe loop	Keystone 5015	5015
19	1	D1	600 V 200 mA	Rohm	RFU02VSM6STR
20	2	D5, D15	40 V 30 mA	Diodes Inc.	SDM03U40-7
21	1	U1	600 V HB GaN FET gate driver	On Semiconductor	NCP51820AMNTWG
22	1	U2	2 input AND, TinyLogic, 1.65 V-5.5 V, +-32 mA	Fairchild	NC7SZ08L6X
23	1	U3	2 input NAND, TinyLogic, 1.65 V-5.5 V, +-32 mA	Fairchild	NC7SZ00L6X
24	1	J1	2x1 0.1 male vertical through hole	Würth	61300211121
25	1	J7	2x12 0.1 male vertical through hole	Tyco	4-103185-0-04
26	1	J10	4x1 0.1 male vertical through hole	TE Connectivity	4-103185-0-04

Optional Components

Item	Qty	Reference	Part Description	Manufacturer	Part Number
1	2	R1, R2	0 Ω	Stackpole	RMCF0402ZT0R00
2	1	R6	0 Ω	Stackpole	RMCF0603ZT0R00
3	1	Cout1	Cout_generic	TBD	TBD
4	1	EN1	0.1 male vertical 1 position 0.1 pitch	Würth	61300111121
5	3	J3, J4, J6	MMCX Jack Vertical SMT 50 Ω	Molex	734152063
6	1	J12	7.62 mm Euro Term	Würth	691216410002
7	1	L1	GenericOutputInductor	TBD	TBD
8	1	P1	250 k	Bourns	PV37W254C01B00
9	1	R11	R0603-TBD	TBD	TBD

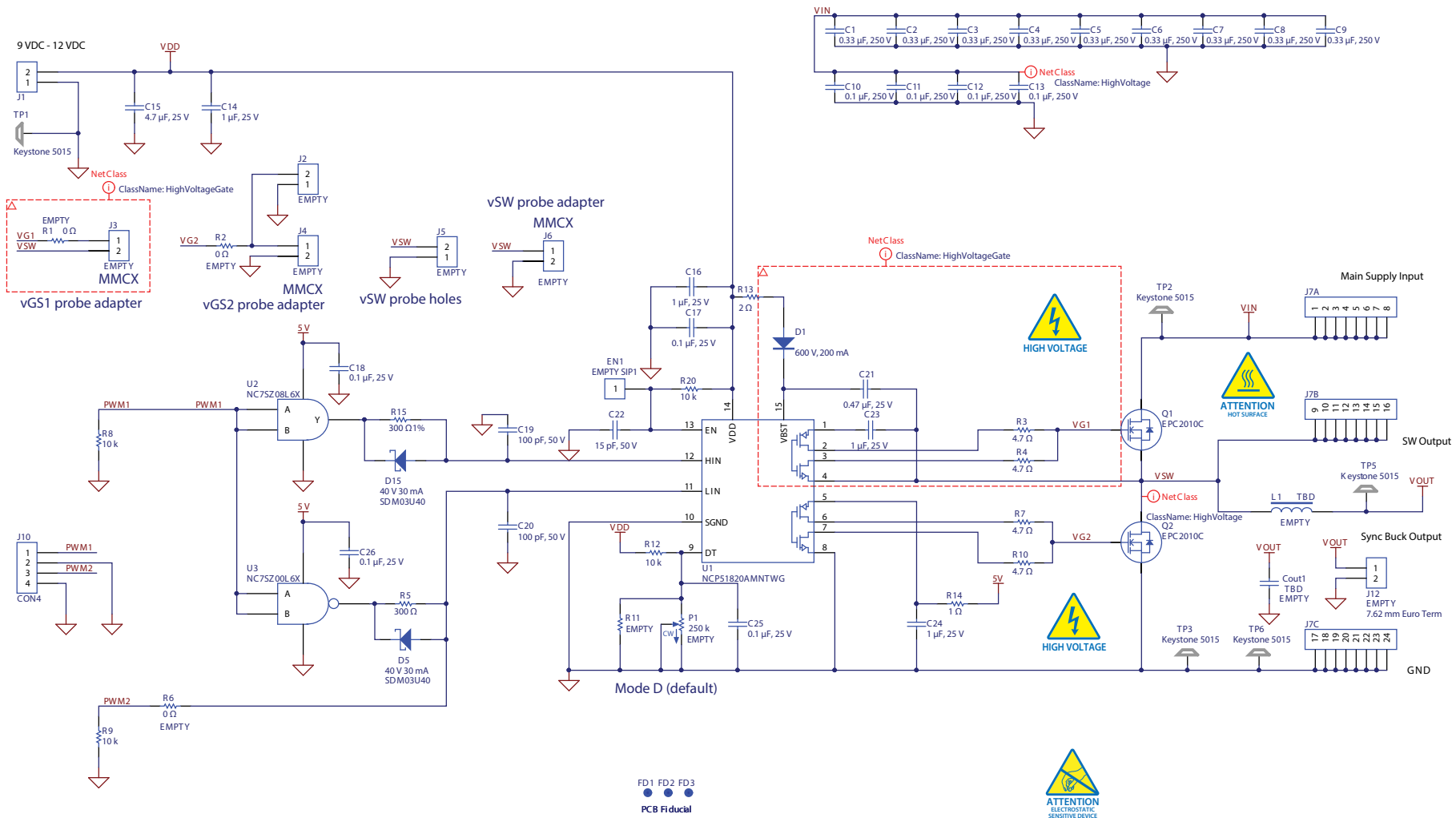

Figure 7: EPC9003C main schematic

For More Information:

Please contact info@epc-co.com
or your local sales representative

Visit our website:
www.epc-co.com

Sign-up to receive
EPC updates at
bit.ly/EPCupdates
or text "EPC" to 22828



EPC Products are distributed through Digi-Key.
www.digikey.com

Demonstration Board Notification

The EPC9003C board is intended for product evaluation purposes only. It is not intended for commercial use nor is it FCC approved for resale. Replace components on the Evaluation Board only with those parts shown on the parts list (or Bill of Materials) in the Quick Start Guide. Contact an authorized EPC representative with any questions. This board is intended to be used by certified professionals, in a lab environment, following proper safety procedures. Use at your own risk.

As an evaluation tool, this board is not designed for compliance with the European Union directive on electromagnetic compatibility or any other such directives or regulations. As board builds are at times subject to product availability, it is possible that boards may contain components or assembly materials that are not RoHS compliant. Efficient Power Conversion Corporation (EPC) makes no guarantee that the purchased board is 100% RoHS compliant.

The Evaluation board (or kit) is for demonstration purposes only and neither the Board nor this Quick Start Guide constitute a sales contract or create any kind of warranty, whether express or implied, as to the applications or products involved.

Disclaimer: EPC reserves the right at any time, without notice, to make changes to any products described herein to improve reliability, function, or design. EPC does not assume any liability arising out of the application or use of any product or circuit described herein; neither does it convey any license under its patent rights, or other intellectual property whatsoever, nor the rights of others.