

AOC-O-O-400G-XM-C
ARISTA NETWORKS 400GBASE-AOC OSFP MMF
850NM, UP TO 30M LENGTH



AOC-O-O-400G-XM-C

Arista Networks® Compatible TAA Compliant 400GBase-AOC OSFP Active Optical Cable (MMF, 850nm, Up to 30m)

Features

- OSFP MSA compliant
- 8 parallel full-duplex channels
- Compliant to IEEE802.3bs
- Up to 100m OM3 MMF transmission
- Operating case temperature: 0°C to 70°C
- 8x53.125Gb/s electrical interface (400GAUI-8)
- Data Rate 53.125Gbps (PAM4) per channel
- Maximum power consumption 12W
- RoHS compliant



Applications

- 400G Ethernet
- Infiniband EDR

Product Description

This is an Arista Networks® AOC-O-O-400G-XM compatible 400GBase-AOC OSFP to OSFP active optical cable that operates over multi-mode fiber with a maximum reach up to 30.0m (98.4ft). At a wavelength of 850nm, it has been programmed, uniquely serialized, and data-traffic and application tested to ensure it is 100% compliant and functional. This active optical cable is TAA (Trade Agreements Act) compliant, and is built to comply with MSA (Multi-Source Agreement) standards. We stand behind the quality of our products and proudly offer a limited lifetime warranty.

ProLabs' active optical cables are RoHS compliant and lead-free.

TAA refers to the Trade Agreements Act (19 U.S.C. & 2501-2581), which is intended to foster fair and open international trade. TAA requires that the U.S. Government may acquire only "U.S. – made or designated country end products."



Order Information

Part Number	Description
AOC-O-O-400G-1M-C	Arista Networks® AOC-O-O-400G-1M Compatible TAA Compliant 400GBase-AOC OSFP Active Optical Cable (MMF, 850nm, 1m)
AOC-O-O-400G-2M-C	Arista Networks® AOC-O-O-400G-2M Compatible TAA Compliant 400GBase-AOC OSFP Active Optical Cable (MMF, 850nm, 2m)
AOC-O-O-400G-3M-C	Arista Networks® AOC-O-O-400G-3M Compatible TAA Compliant 400GBase-AOC OSFP Active Optical Cable (MMF, 850nm, 3m)
AOC-O-O-400G-4M-C	Arista Networks® AOC-O-O-400G-4M Compatible TAA Compliant 400GBase-AOC OSFP Active Optical Cable (MMF, 850nm, 4m)
AOC-O-O-400G-5M-C	Arista Networks® AOC-O-O-400G-5M Compatible TAA Compliant 400GBase-AOC OSFP Active Optical Cable (MMF, 850nm, 5m)
AOC-O-O-400G-6M-C	Arista Networks® AOC-O-O-400G-6M Compatible TAA Compliant 400GBase-AOC OSFP Active Optical Cable (MMF, 850nm, 6m)
AOC-O-O-400G-7M-C	Arista Networks® AOC-O-O-400G-7M Compatible TAA Compliant 400GBase-AOC OSFP Active Optical Cable (MMF, 850nm, 7m)
AOC-O-O-400G-8M-C	Arista Networks® AOC-O-O-400G-8M Compatible TAA Compliant 400GBase-AOC OSFP Active Optical Cable (MMF, 850nm, 8m)
AOC-O-O-400G-9M-C	Arista Networks® AOC-O-O-400G-9M Compatible TAA Compliant 400GBase-AOC OSFP Active Optical Cable (MMF, 850nm, 9m)
AOC-O-O-400G-10M-C	Arista Networks® AOC-O-O-400G-10M Compatible TAA Compliant 400GBase-AOC OSFP Active Optical Cable (MMF, 850nm, 10m)
AOC-O-O-400G-15M-C	Arista Networks® AOC-O-O-400G-15M Compatible TAA Compliant 400GBase-AOC OSFP Active Optical Cable (MMF, 850nm, 15m)
AOC-O-O-400G-20M-C	Arista Networks® AOC-O-O-400G-20M Compatible TAA Compliant 400GBase-AOC OSFP Active Optical Cable (MMF, 850nm, 20m)
AOC-O-O-400G-25M-C	Arista Networks® AOC-O-O-400G-25M Compatible TAA Compliant 400GBase-AOC OSFP Active Optical Cable (MMF, 850nm, 25m)
AOC-O-O-400G-30M-C	Arista Networks® AOC-O-O-400G-30M Compatible TAA Compliant 400GBase-AOC OSFP Active Optical Cable (MMF, 850nm, 30m)

Absolute Maximum Ratings

Parameter	Symbol	Min	Typ.	Max.	Unit	Notes
Storage Temperature	TS	-40		85	degC	
Operating Case Temperature	TOP	0		70	degC	
Power Supply Voltage	VCC	-0.5		3.6	V	
Relative Humidity (non-condensation)	RH	0		85	%	
Data Rate, each Lane			26.5625		GBd	PAM4
Data Rate Accuracy		-100		100	ppm	
Pre-FEC Bit Error Ratio				2.4×10^{-4}		
Post-FEC Bit Error Ratio				1×10^{-12}		1
Link Distance with OM3	D	0.5		100	m	2

Notes:

1. FEC provided by host system.
2. FEC required on host system to support maximum distance.

Electrical Characteristics

Parameter	Test Point	Min.	Typ.	Max.	Unit.	Notes
Power Supply Voltage	Vcc	3.135	3.3	3.465	V	
Power Consumption				12	W	
Supply Current	Icc			3.63	A	
Transmitter (each Lane)						
Signaling Rate, each Lane	TP1	26.5625 ± 100 ppm			GBd	
Differential pk-pk Input Voltage Tolerance	TP1a	900			mVpp	1
Differential Termination Mismatch	TP1			10	%	
Differential Input Return Loss	TP1	IEEE 802.3-2015 Equation (83E- 5)			dB	
Differential to Common Mode Input Return Loss	TP1	IEEE 802.3-2015 Equation (83E- 6)			dB	
Module Stressed Input Test	TP1a	See IEEE 802.3bs 120E.3.4.1				2
Single-ended Voltage Tolerance Range (Min)	TP1a	-0.4 to 3.3			V	
DC Common Mode Input Voltage	TP1	-350		2850	mV	3
Receiver (each Lane)						
Signaling Rate, each lane	TP4	26.5625 ± 100 ppm			GBd	
Differential Peak-to-Peak Output Voltage	TP4			900	mVpp	
AC Common Mode Output Voltage, RMS	TP4			17.5	mV	
Differential Termination Mismatch	TP4			10	%	
Differential Output Return Loss	TP4	IEEE 802.3-2015 Equation (83E- 2)				
Common to Differential Mode Conversion Return Loss	TP4	IEEE 802.3-2015 Equation (83E- 3)				
Transition Time, 20% to 80%	TP4	9.5			ps	
Near-end Eye Symmetry Mask Width (ESMW)	TP4		0.265		UI	
Near-end Eye Height, Differential	TP4	70			mV	
Far-end Eye Symmetry Mask Width (ESMW)	TP4		0.2		UI	
Far-end Eye Height, Differential	TP4	30			mV	
Far-end Pre-cursor ISI Ratio	TP4	-4.5		2.5	%	
Common Mode Output Voltage (Vcm)	TP4	-350		2850	mV	3

Notes:

1. With the exception to IEEE 802.3bs 120E.3.1.2 that the pattern is PRBS31Q or scrambled idle.
2. Meets BER specified in IEEE 802.3bs 120E.1.1.
3. DC common mode voltage generated by the host. Specification includes effects of ground offset voltage.

Voltage Zones

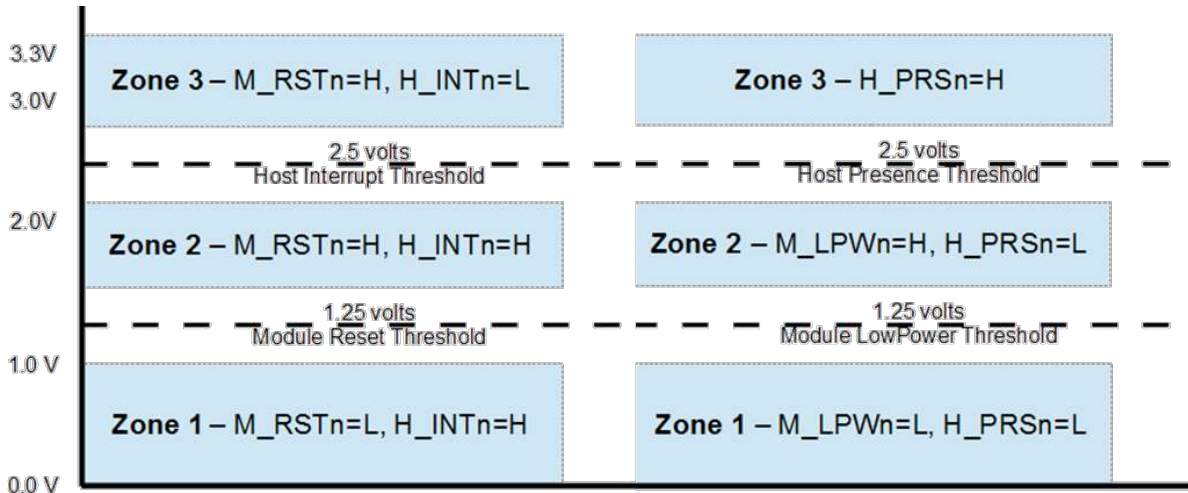

Electrical Pin-out Assignment

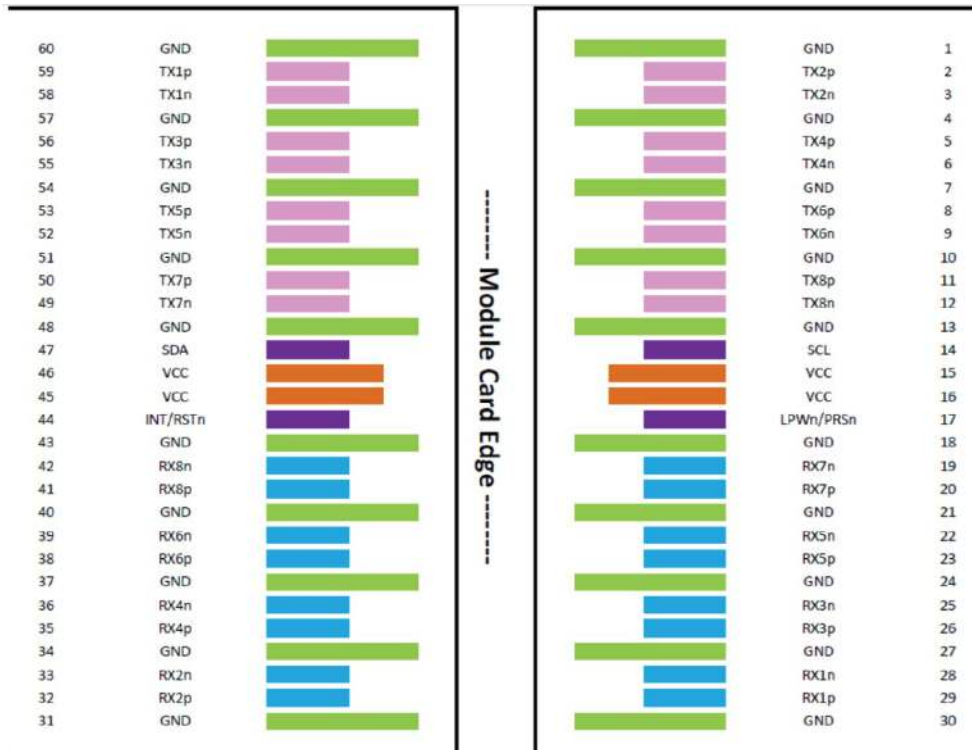

Pin Descriptions

Pin #	Symbol	Description	Logic	Direction	Plug Sequence
1	GND		Ground		1
2	TX2p	Transmitter Data Non-Inverted	CML-I	Input from Host	3
3	TX2n	Transmitter Data Inverted	CML-I	Input from Host	3
4	GND		Ground		1
5	TX4p	Transmitter Data Non-Inverted	CML-I	Input from Host	3
6	TX4n	Transmitter Data Inverted	CML-I	Input from Host	3
7	GND		Ground		1
8	TX6p	Transmitter Data Non-Inverted	CML-I	Input from Host	3
9	TX6n	Transmitter Data Inverted	CML-I	Input from Host	3
10	GND		Ground		1
11	TX8p	Transmitter Data Non-Inverted	CML-I	Input from Host	3
12	TX8n	Transmitter Data Inverted	CML-I	Input from Host	3
13	GND		Ground		1
14	SCL	2-wire Serial interface clock	LVC MOS-I/O	Bi-directional	3
15	VCC	+3.3V Power		Power from Host	2
16	VCC	+3.3V Power		Power from Host	2
17	LPWn/PRSn	Low-Power Mode / Module Present	Multi-Level	Bi-directional	3
18	GND		Ground		1
19	RX7n	Receiver Data Inverted	CML-O	Output to Host	3
20	RX7p	Receiver Data Non-Inverted	CML-O	Output to Host	3
21	GND		Ground		1
22	RX5n	Receiver Data Inverted	CML-O	Output to Host	3
23	RX5p	Receiver Data Non-Inverted	CML-O	Output to Host	3
24	GND		Ground		1
25	RX3n	Receiver Data Inverted	CML-O	Output to Host	3
26	RX3p	Receiver Data Non-Inverted	CML-O	Output to Host	3
27	GND		Ground		1
28	RX1n	Receiver Data Inverted	CML-O	Output to Host	3
29	RX1p	Receiver Data Non-Inverted	CML-O	Output to Host	3
30	GND		Ground		1
31	GND		Ground		1
32	RX2p	Receiver Data Non-Inverted	CML-O	Output to Host	3
33	RX2n	Receiver Data Inverted	CML-O	Output to Host	3
34	GND		Ground		1
35	RX4p	Receiver Data Non-Inverted	CML-O	Output to Host	3
36	RX4n	Receiver Data Inverted	CML-O	Output to Host	3
37	GND		Ground		1
38	RX6p	Receiver Data Non-Inverted	CML-O	Output to Host	3

Pin #	Symbol	Description	Logic	Direction	Plug Sequence
39	RX6n	Receiver Data Inverted	CML-O	Output to Host	3
40	GND		Ground		1
41	RX8p	Receiver Data Non-Inverted	CML-O	Output to Host	3
42	RX8n	Receiver Data Inverted	CML-O	Output to Host	3
43	GND		Ground		1
44	INT/RSTn	Module Interrupt / Module Reset	Multi-Level	Bi-directional	3
45	VCC	+3.3V Power		Power from Host	2
46	VCC	+3.3V Power		Power from Host	2
47	SDA	2-wire Serial interface data	LVC MOS-I/O	Bi-directional	3
48	GND		Ground		1
49	TX7n	Transmitter Data Inverted	CML-I	Input from Host	3
50	TX7p	Transmitter Data Non-Inverted	CML-I	Input from Host	3
51	GND		Ground		1
52	TX5n	Transmitter Data Inverted	CML-I	Input from Host	3
53	TX5p	Transmitter Data Non-Inverted	CML-I	Input from Host	3
54	GND		Ground		1
55	TX3n	Transmitter Data Inverted	CML-I	Input from Host	3
56	TX3p	Transmitter Data Non-Inverted	CML-I	Input from Host	3
57	GND		Ground		1
58	TX1n	Transmitter Data Inverted	CML-I	Input from Host	3
59	TX1p	Transmitter Data Non-Inverted	CML-I	Input from Host	3
60	GND		Ground		1

AOC Block Diagram

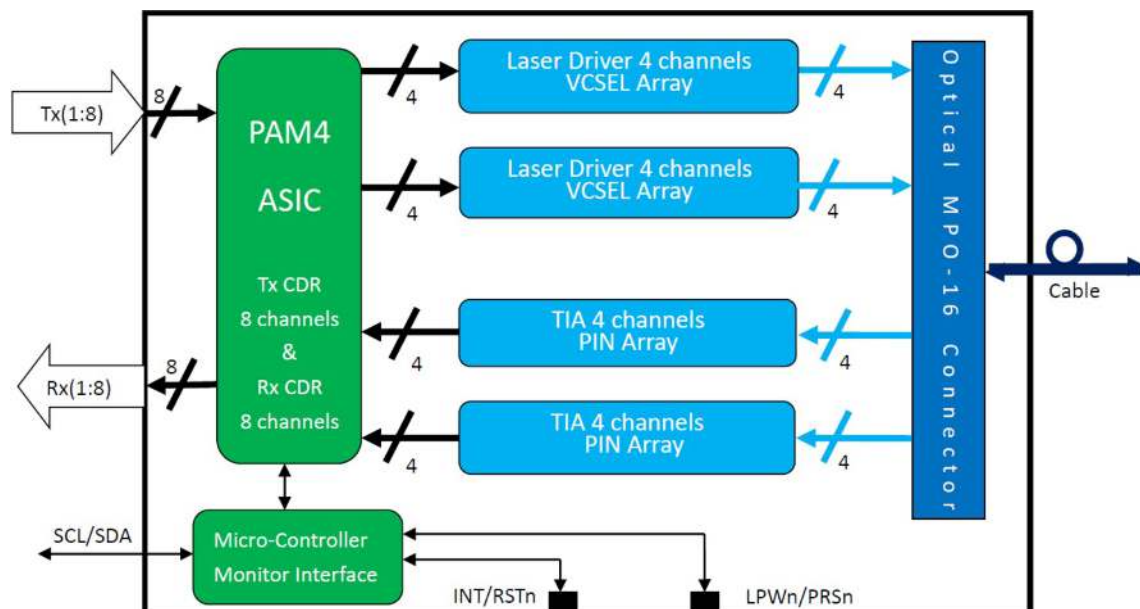

Recommended Power Supply Filter

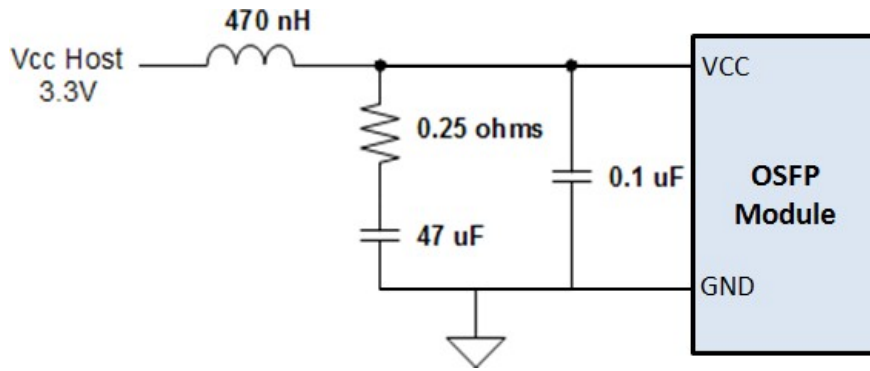

Mechanical Specifications

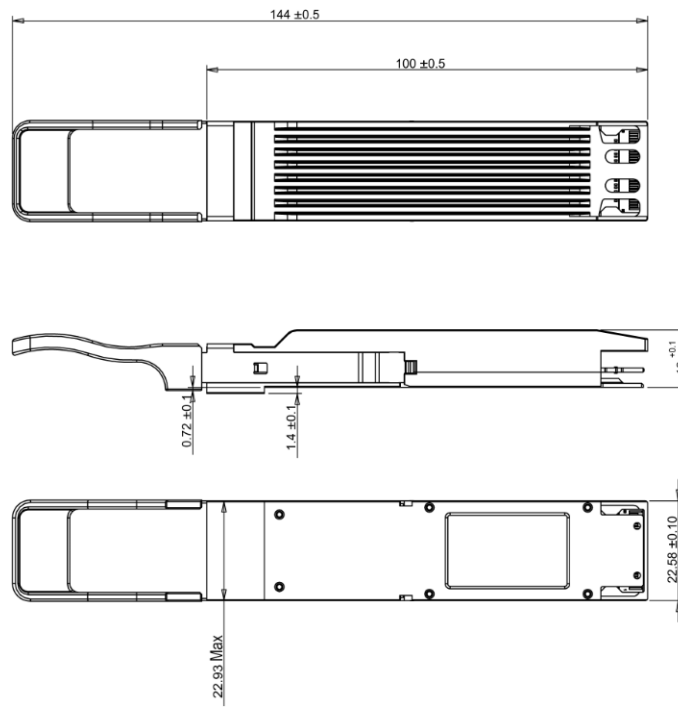

About ProLabs

Our experience comes as standard; for over 15 years ProLabs has delivered optical connectivity solutions that give our customers freedom and choice through our ability to provide seamless interoperability. At the heart of our company is the ability to provide state-of-the-art optical transport and connectivity solutions that are compatible with over 90 optical switching and transport platforms.

Complete Portfolio of Network Solutions

ProLabs is focused on innovations in optical transport and connectivity. The combination of our knowledge of optics and networking equipment enables ProLabs to be your single source for optical transport and connectivity solutions from 100Mb to 400G while providing innovative solutions that increase network efficiency. We provide the optical connectivity expertise that is compatible with and enhances your switching and transport equipment.

Trusted Partner

Customer service is our number one value. ProLabs has invested in people, labs and manufacturing capacity to ensure that you get immediate answers to your questions and compatible product when needed. With Engineering and Manufacturing offices in the U.K. and U.S. augmented by field offices throughout the U.S., U.K. and Asia, ProLabs is able to be our customers best advocate 24 hours a day.

Contact Information

ProLabs US

Email: sales@prolabs.com

Telephone: 952-852-0252

ProLabs UK

Email: salessupport@prolabs.com

Telephone: +44 1285 719 600