

THIS DRAWING IS UNPUBLISHED. RELEASED FOR PUBLICATION  
 © COPYRIGHT BY TYCO ELECTRONICS CORPORATION. ALL INTERNATIONAL RIGHTS RESERVED.

LOC		DIST		REVISIONS			
P	LTR	DESCRIPTION		DATE	DWN	APVD	
	G	REV PER ECO-10-002919		24MAR10	PY	DM	

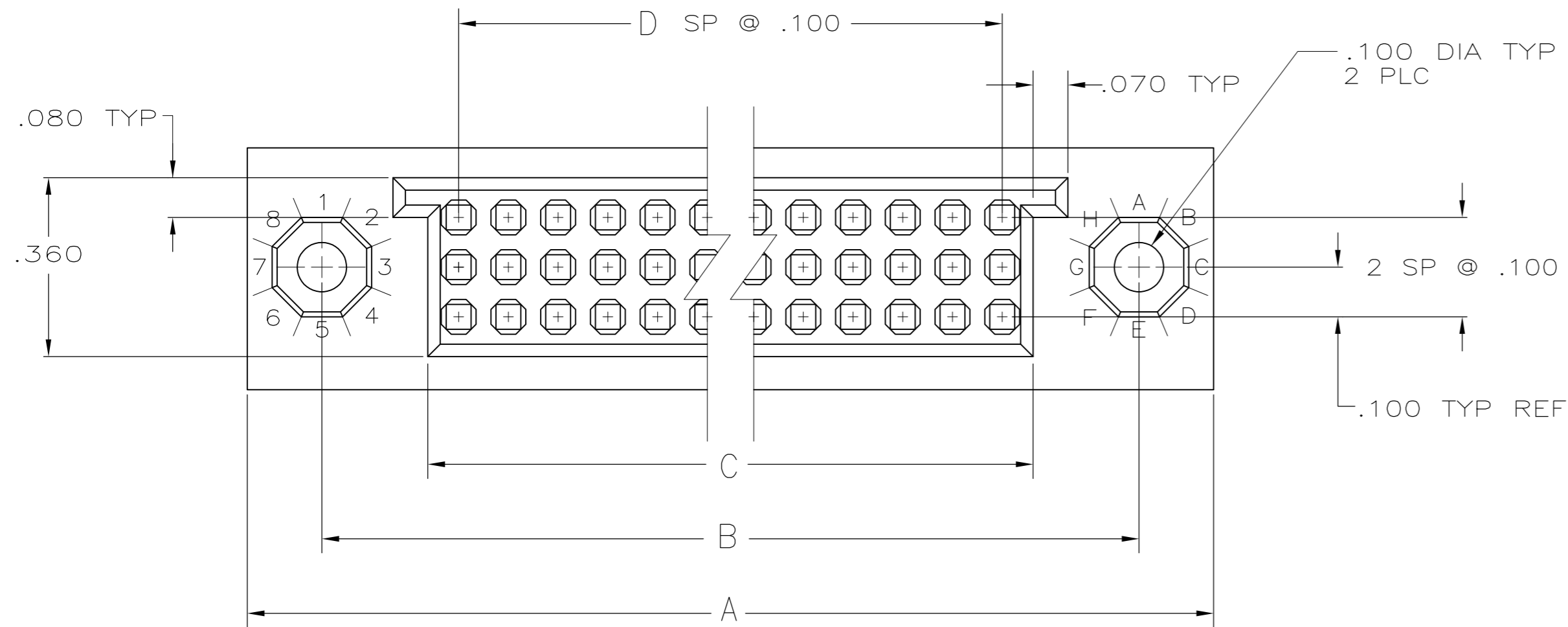

- 1 HOUSING MATERIAL: POLYPHENYLENE SULFIDE. COLOR: NATURAL (BROWN).
- 2 POST MATERIAL: PHOSPHOR BRONZE.
- 3 POST FINISH: .000050 - .000100 NICKEL UNDERPLATE ALL OVER, .000050 GOLD IN CONTACT AREA. .000030 GOLD ON POSTS.
- 4. THIS CONNECTOR IS DESIGNED FOR NON-AUTOMATIC WIRE-WRAP APPLICATIONS ONLY.
- 5 TE, PART NUMBER AND DATE CODE MARKED IN THIS APPROXIMATE AREA.

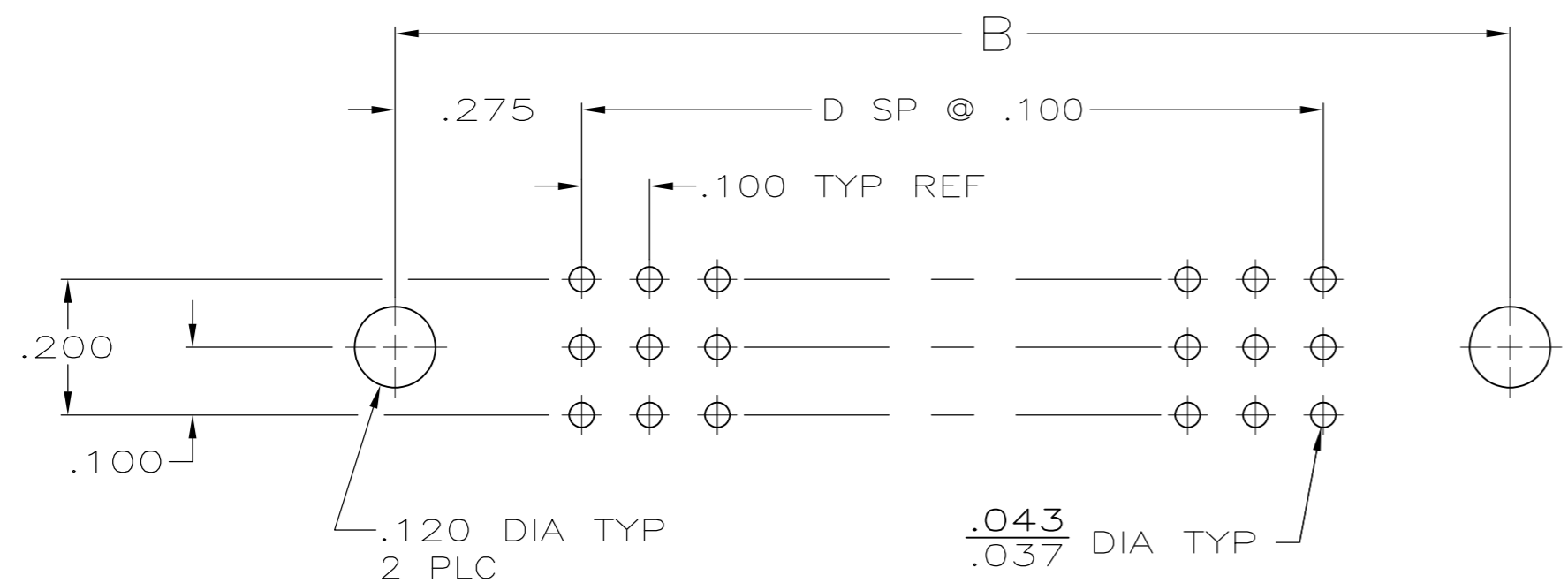
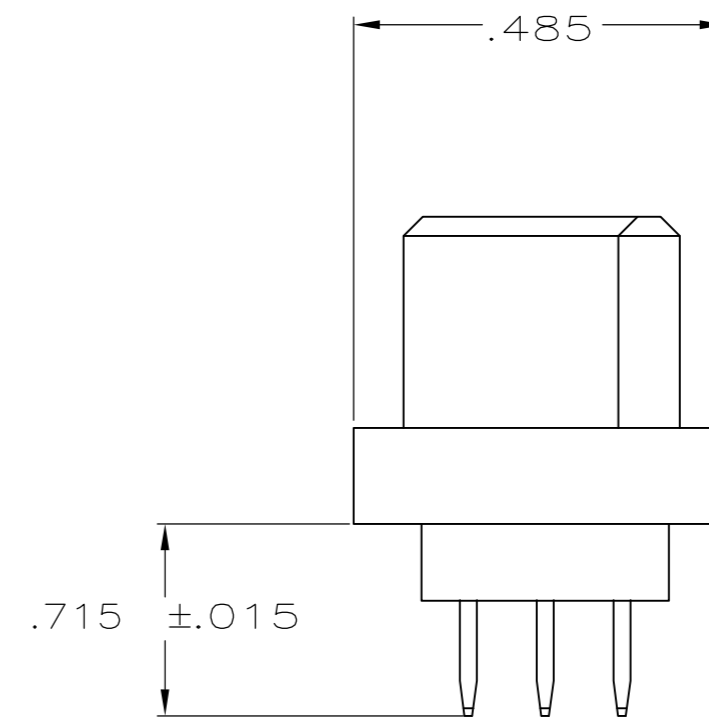
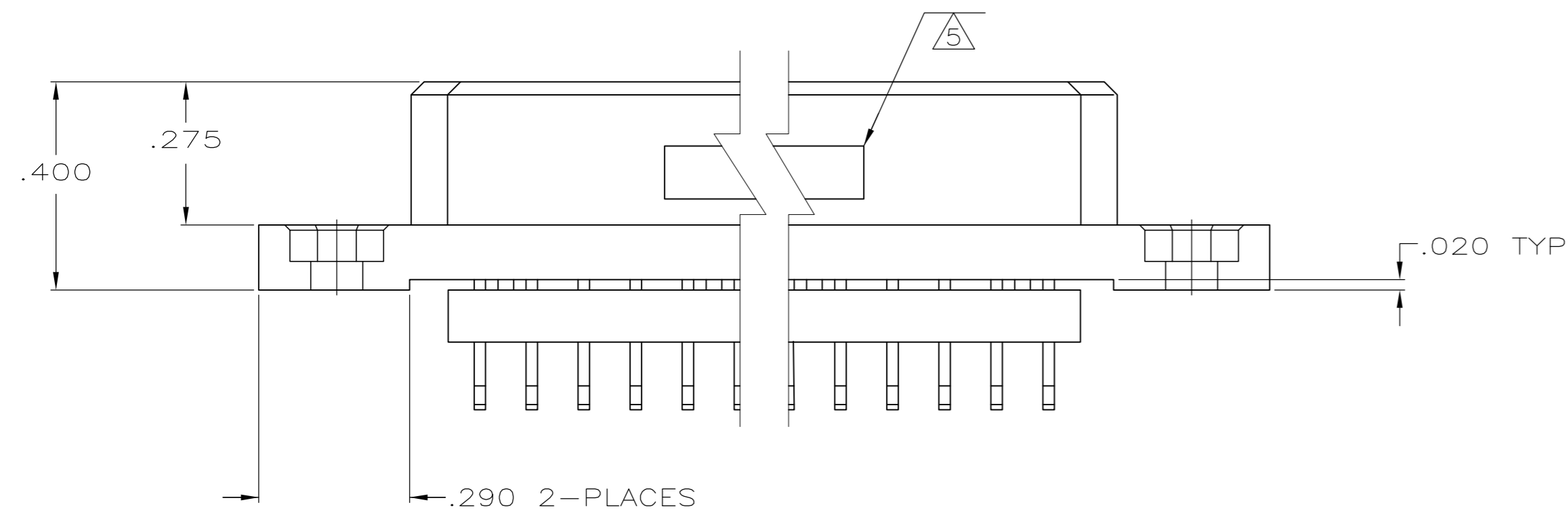

PC BOARD LAYOUT

31	3.224	3.650	3.950	96	533493-1
D	C	B	A	POSN	PART NUMBER

THIS DRAWING IS A CONTROLLED DOCUMENT.		DWN L.BRINER 02-09-87	Tyco Electronics Corporation Harrisburg, PA 17105-3608		
DIMENSIONS: INCHES		CHK V.WEBSTER 02-09-87			
TOLERANCES UNLESS OTHERWISE SPECIFIED:		APVD V.WEBSTER 02-09-87	NAME		
0 PLC ± - 1 PLC ± - 2 PLC ± - 3 PLC ± .005 4 PLC ± - ANGLES ± - FINISH -		PRODUCT SPEC	BOX II ASSEMBLY 3 ROW, WITH WIRE WRAP POSTS AND STABILIZER		
MATERIAL		APPLICATION SPEC	SIZE A2	CAGE CODE 00779	DRAWING NO C=533493
		WEIGHT -	RESTRICTED TO		
CUSTOMER DRAWING			SCALE 4:1	SHEET 1 of 1	REV G